

**fiida**.s.r.l.

*A Beckett Company*



# COMPACT

TRASFORMATORI PER BRUCIATORI E ZANZARIERE

## INFORMAZIONI E AVVERTENZE

- CAVO DI ALIMENTAZIONE CON SPINA
  - LUNGHEZZA CAVO STANDARD mm.450. ALTRE LUNGHEZZE A RICHIESTA
  - SE IL CAVO DI ALIMENTAZIONE DEVE ESSERE SOSTITUITO, LA SOSTITUZIONE DEVE ESSERE ESEGUITA CON UN NUOVO CAVO DI ALIMENTAZIONE FIDA
  - CAVI DI ALTA TENSIONE DISPONIBILI A RICHIESTA
  - IL TRASFORMATORE DI ACCENSIONE DEVE ESSERE USATO CON UNITA' DI CONTROLLO
  - SUL BRUCIATORE DEVE ESSERE MESSO IL SIMBOLO " ALTA TENSIONE ": UN TRIANGOLO GIALLO CON UN LAMPO NERO
  - IL TRASFORMATORE DI ACCENSIONE E' PROTETTO DA POLVERE E UMIDITA', UTILIZZANDO CAVI AT FIDA CON GOMMINO
  - CARETTERISTICHE DI TENSIONE DIVERSE, A RICHIESTA (120V , 60 Hz E ALTRE)
- 

## AUSKÜNFTE UND WARNUNGEN

- STROMVERSORGUNGSKABEL MIT ANSCHLUßSTECKER
  - STANDARD KABELSLÄNGE mm.450. VERSCHIEDENEN LÄNGEN AUF WUNSCH
  - MUß DAS SPEISEKABEL ERNUERT WERDEN, MUß DIE ERNEUERUNG MIT EINEM NEUEN FIDA SPEISEKABEL GEMACHT WERDEN
  - HOCHSPANNUNGSKABEL ZUR VERFÜGUNG AIF WUNSCH
  - DER ZÜNDTRANSFORMATOR MUß MIT EINE KONTROLLEEINHEIT BENÜTZT WERDEN
  - AM BRENNER MUß DER SYMBOL "HOCHSPANNUNG" GESTELLT WERDEN: EIN GELBE DREIECK MIT EINEM SCHWARZEN BLITZ
  - GESCHÜTZT VOR STAUB UND FEUCHTIGKEIT, WENN MAN FIDA HOCHSPANNUNGSKABEL MIT DER SCHÜTZKAPPE BENUTZT WIRD.
  - VERSCHIEDENEN SPANNUNGSMERKMALEN AUF WUNSCH (120V, 60 Hz u.s.w.)
- 

## INFORMATIONS AND DIRECTIONS

- FEEDING CABLE WITH CONNECTOR
- STANDARD CABLE LENGTH mm.450. DIFFERENT LENGTHS ON DEMAND
- IF THE FEEDING CABLE HAS TO BE SUBSTITUTED, THE SUBSTITUTION MUST BE DONE WITH A NEW FIDA'S FEEDING CABLE
- HIGH TENSION CABLES AVAILABLE ON DEMAND
- THE IGNITION TRANSFORMER MUST BE USED WITH A CONTROL UNIT
- ON THE BURNER MUST BE PUT THE SYMBOL "HIGH VOLTAGE": A YELLOW TRIANGLE WITH A BLACK LIGHTNING
- THE IGNITION TRANSFORMER IS PROTECTED FROM DUST AND DAMP, USING FIDA'S CABLES WITH CAP.
- DIFFERENT TENSION CHARACTERISTICS ON DEMAND (120V, 60 Hz AND OTHERS)

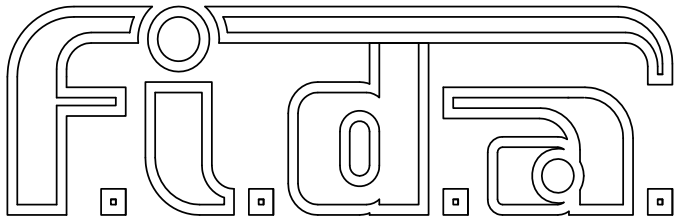

31021 MOGLIANO (TREVISO) - ITALY -  
VIA TIZIANO, 14 - TEL. 041 / 5970120  
FAX 041 / 5970116

BUILT IN IGNITION TRANSFORMERS  
EINBAU ZÜNDTRANSFORMATOREN  
TRANSFORMATEURS D'ALLUMAGE A INCORPORER  
TRASFORMATORI D'ACCENSIONE DA INCORPORARE

“COMPACT”

DISEGNO DI PROPRIETA' DELLA FIDA CON DIVIETO DI DIVULGAZIONE  
E DI RIPRODUZIONE SALVO AUTORIZZAZIONE. LA FIDA SI RISERVA  
DI APPORTARE MODIFICHE SENZA PREAVVISO.

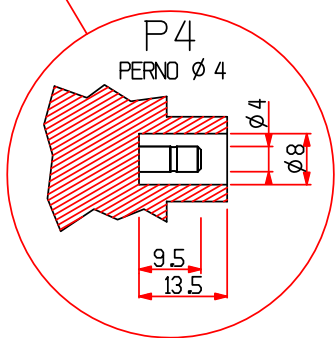
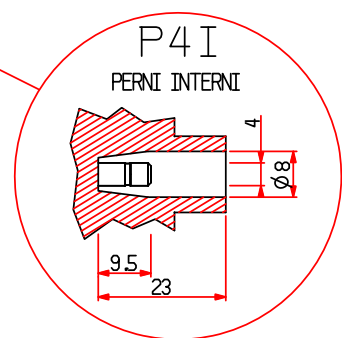
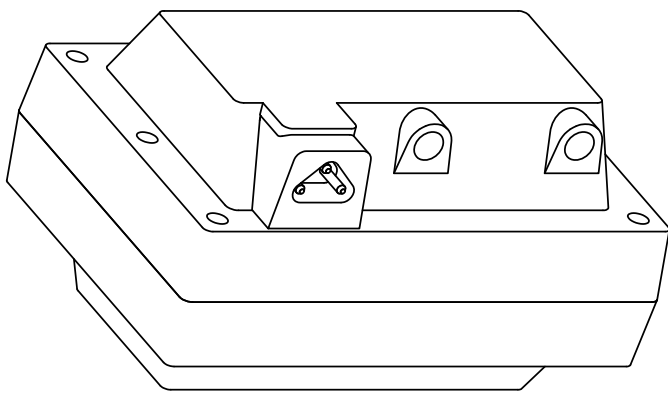
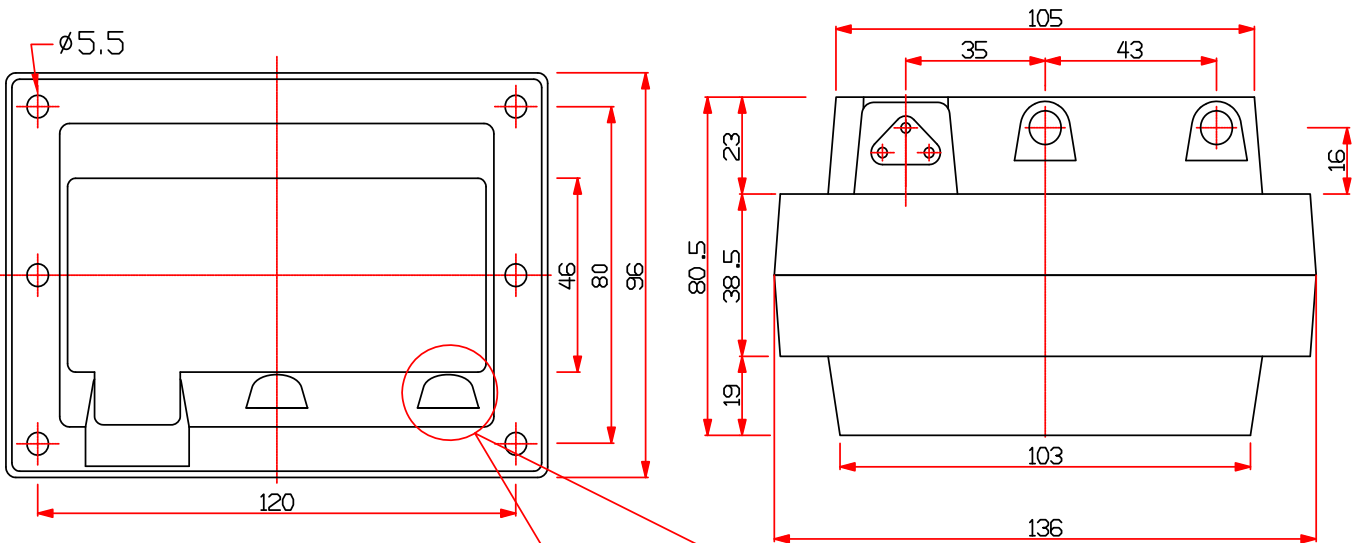

Ref.=G



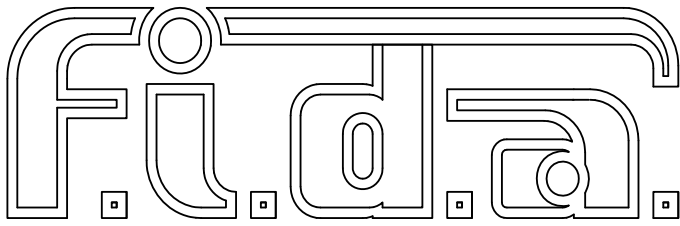

31021 MOGLIANO (TREVISO) - ITALY -  
VIA TIZIANO, 14 - TEL. 041 / 5970120  
FAX 041 / 5970116

BUILT IN IGNITION TRANSFORMERS  
EINBAU ZÜNDTRANSFORMATOREN  
TRANSFORMATEURS D'ALLUMAGE A INCORPORER  
TRASFORMATORI D'ACCENSIONE DA INCORPORARE

“COMPACT”

DISEGNO DI PROPRIETA' DELLA FIDA CON DIVIETO DI DIVULGAZIONE  
E DI RIPRODUZIONE SALVO AUTORIZZAZIONE. LA FIDA SI RISERVA  
DI APPORTARE MODIFICHE SENZA PREAVVISO.

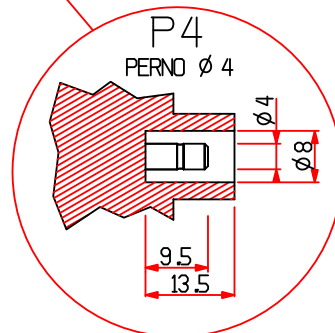
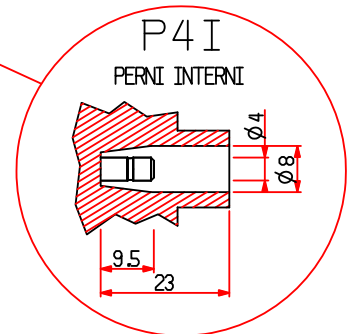
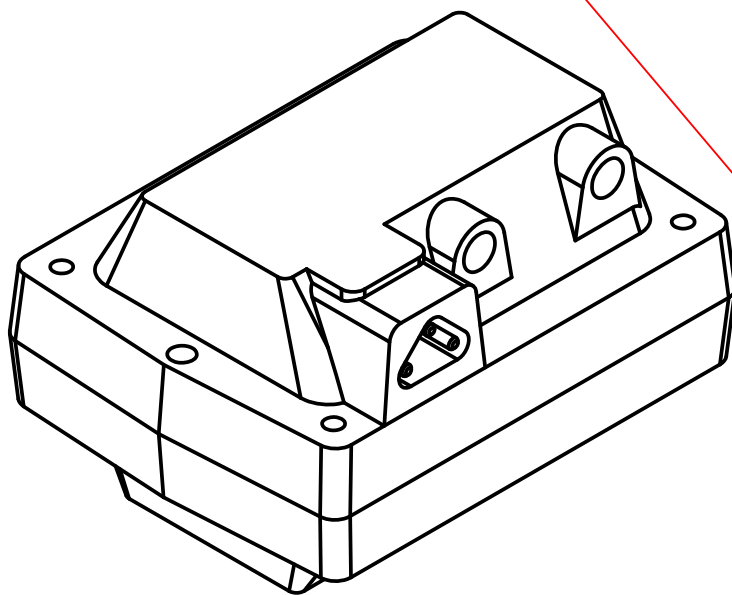
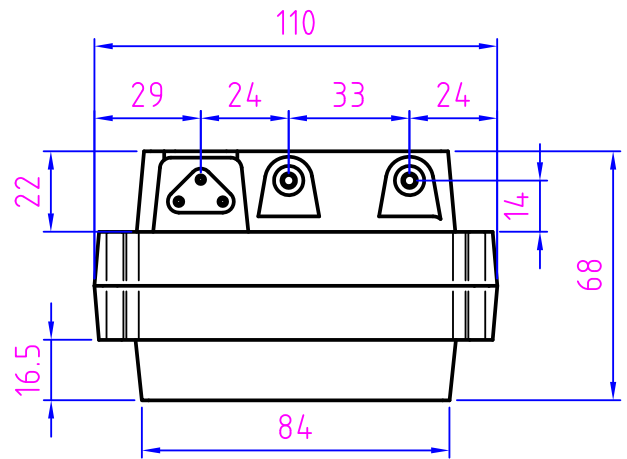
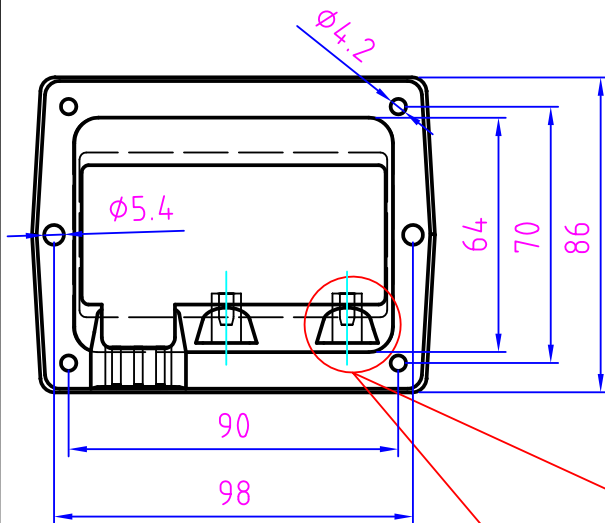

Ref.=M

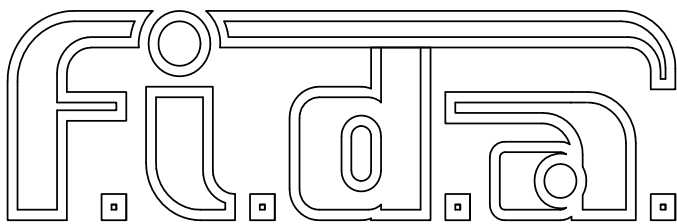

BUILT IN IGNITION TRANSFORMERS  
EINBAU ZUENDTRANSFORMATOREN  
TRANSFORMATEURS D'ALLUMAGE A INCORPORER  
TRASFORMATORI D'ACCENSIONE DA INCORPORARE

“COMPACT”®

I - 31021 MOGLIANO VENETO (Treviso) - ITALY  
Via Tiziano, 14 - S.P.Z.  
Phone: +39 041 5970120 - Fax: +39 041 5970116

DISEGNO DI PROPRIETA' DELLA FIDA CON DIVIETO DI DIVULGAZIONE  
E DI RIPRODUZIONE SALVO AUTORIZZAZIONE. LA FIDA SI RISERVA  
DI APPORTARE MODIFICHE SENZA PREAVVISO.

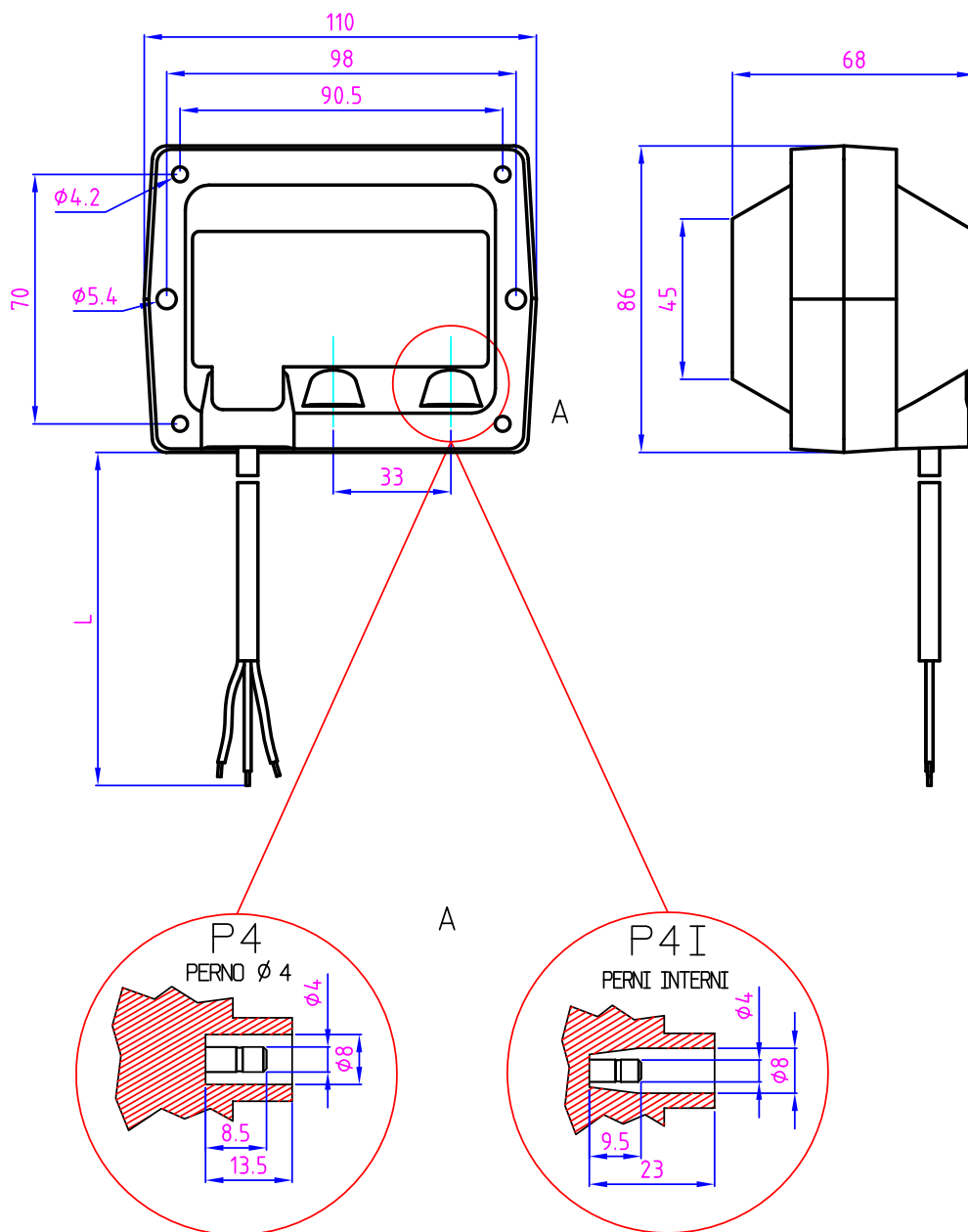

REF.MC

# FIDA

31021 MOGLIANO (TREVISO) - ITALY -  
VIA TIZIANO, 14 - TEL. 041 / 5970120  
FAX 041 / 5970116

BUILT IN IGNITION TRANSFORMERS  
EINBAU ZÜNDTRANSFORMATOREN  
TRANSFORMATEURS D'ALLUMAGE A INCORPORER  
TRASFORMATORI D'ACCENSIONE DA INCORPORARE

## “COMPACT”

DISEGNO DI PROPRIETA' DELLA FIDA CON DIVIETO DI DIVULGAZIONE  
E DI RIPRODUZIONE SALVO AUTORIZZAZIONE. LA FIDA SI RISERVA  
DI APPORTARE MODIFICHE SENZA PREAVVISO.

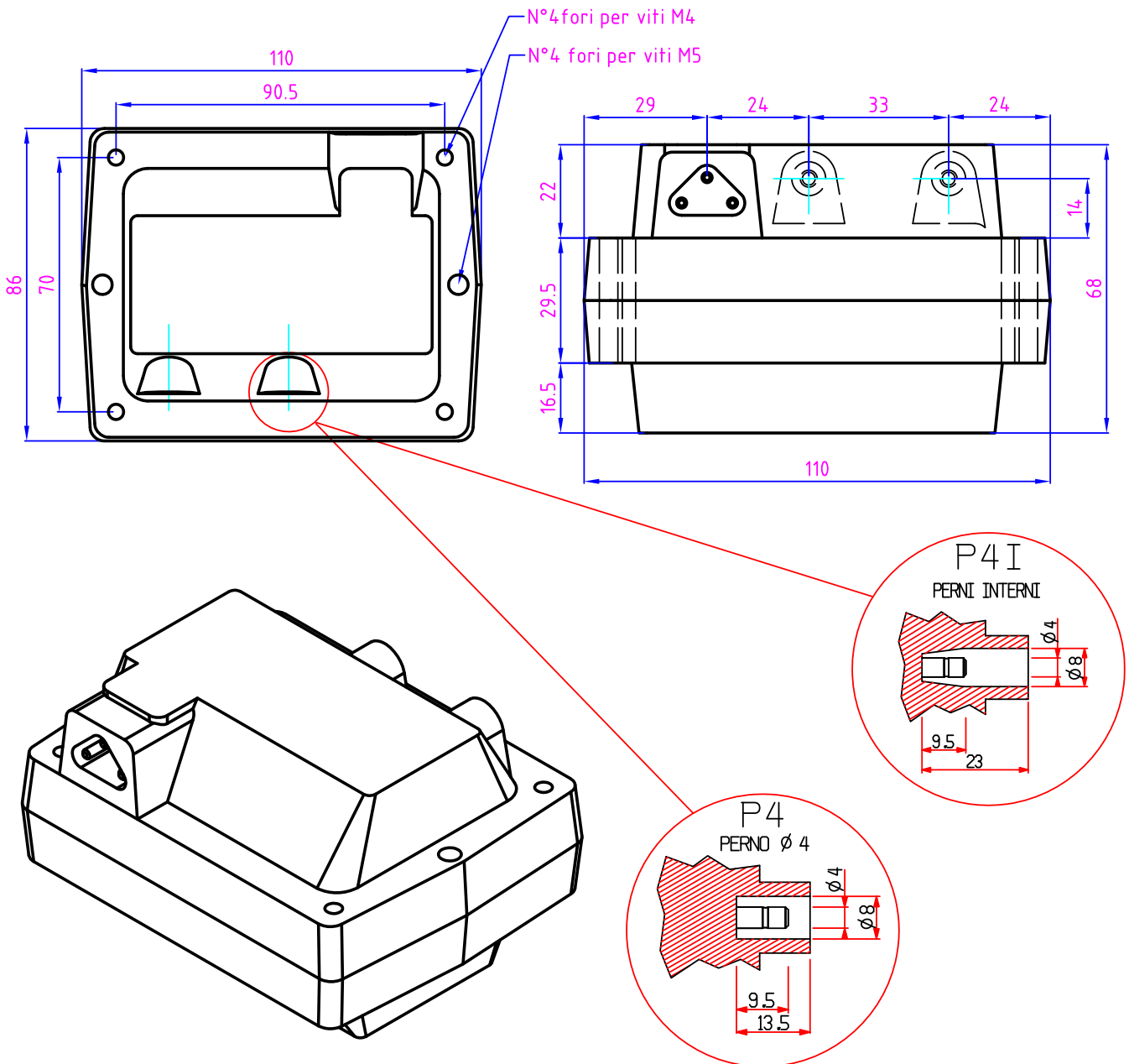

Ref.=MR



I - 31021 MOGLIANO VENETO (Treviso) - ITALY  
Via Tiziano, 14 - S.P.Z.  
Phone: +39 (0)41 5970120 - Fax: +39 (0)41 5970116

BUILT IN IGNITION TRANSFORMERS  
EINBAU ZUENDTRANSFORMATOREN  
TRASFORMATEUR D'ALLUMAGE A INCORPORER  
TRASFORMATORI D'ACCENSIONE DA INCORPORARE

" COMPACT "

TYPE TYP TYPE TIPO	INTERMITTENCE EINSCHALTDAUER INTERMITTENCE INTERMITTENZA	STANDARD POWER SUPPLY STROMVERSORGUNG ALIMENTATION STANDARD ALIMENTAZIONE STANDARD			HIGH TENSION HOCHSPANNUNG HAUTE TENSION ALTA TENSIONE		MARKS ZEICHEN MARQUES MARCHI		
		V	Hz	A	V	mA			
8/10 CM	100%	230	50	0,5	2x4000	10	CE		RoHS
8/10 CM	100%	400	50	0,3	2x4000	10	CE		RoHS
8/14 CM	100%	230	50	0,6	1x8000	14	CE	CONFORMED to EN 61558-2-3	RoHS
8/20 CM	25% su 3'	230	50	1	2x4000	20	CE		RoHS
10/20 CM	25% su 3'	230	50	1,2	2x5000	20	CE		RoHS
10/20 CM	33% su 3'	230	50	1,2	2x5000	20	CE		RoHS
12/20 CM	25% su 3'	230	50	1.4	2x6000	20	CE	CONFORMED to EN 61558-2-3	RoHS
10/30 CM	15% su 4'	230	50	1,45	2x5000	30	CE	CONFORMED to EN 61558-2-3	RoHS
5/18 PM	100%	230	50	0,5	1x5000	18	CE	CONFORMED to EN 61558-2-3	RoHS
6/25 PM	25% su 3'	230	50	1	1x6000	25	CE	CONFORMED to EN 61558-2-3	RoHS
8/20 PM	25% su 3'	230	50	1	1x8000	20	CE		RoHS
8/30 PM	25% su 3'	230	50	1,4	1x8000	30	CE	CONFORMED to EN 61558-2-3	RoHS
<b>REF.</b>	Altre caratteristiche su richiesta - Other types on request.								
GRADO DI PROTEZIONE <b>IP 44</b> UTILIZZANDO CAVI BT E AT FIDA SOVRASTAMPATI PROTECTION DEGREE: <b>IP 44</b> TOGETHER WITH FEEDING CABLE AND HIGH TENSION CABLE OVERPRINTED BY FIDA									
<b>M - P4</b>									
<b>M - P4I</b>									
<b>MR - P</b>	ALIMENTAZIONE LATO OPPOSTO				PRIMARY CABLE ON REVERSE SIDE				
<b>MC - P</b>	CAVO ALIMENTAZIONE NON SEPARABILE				INTEGRATED PRIMARY CABLE				
<b>CM</b>	<b>CENTRO A MASSA MIDPOINT GROUND CONNECTED</b>								
<b>PM</b>	<b>POLO A MASSA ONE POLE GROUND CONNECTED</b>								

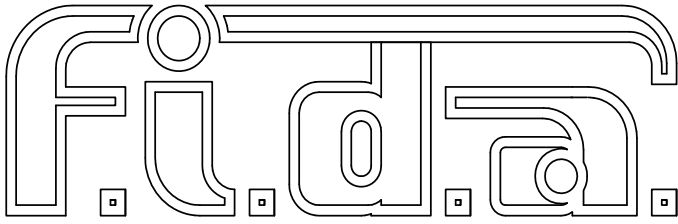

I - 31021 MOGLIANO VENETO (Treviso) - ITALY  
Via Tiziano, 14 - S.P.Z.  
Phone: +39 041 5970120 - Fax: +39 041 5970116

BUILT IN IGNITION TRANSFORMERS  
EINBAU ZUENDTRANSFORMATOREN  
TRANSFORMATEURS D'ALLUMAGE A INCORPORER  
TRASFORMATORI D'ACCENSIONE DA INCORPORARE

“COMPACT”



DISEGNO DI PROPRIETA' DELLA FIDA CON DIVIETO DI DIVULGAZIONE  
E DI RIPRODUZIONE SALVO AUTORIZZAZIONE. LA FIDA SI RISERVA  
DI APPORTARE MODIFICHE SENZA PREAVVISO.

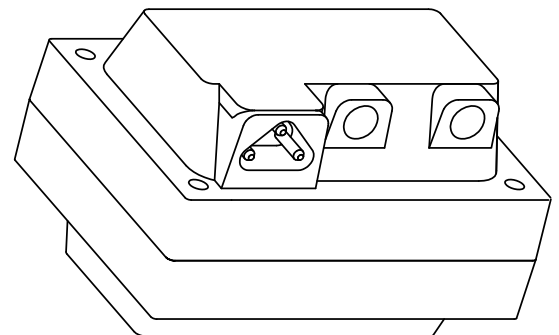
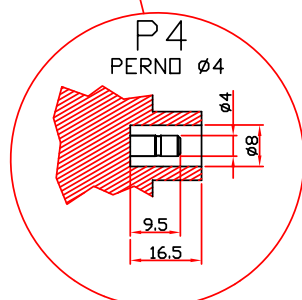
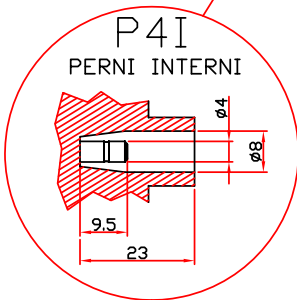
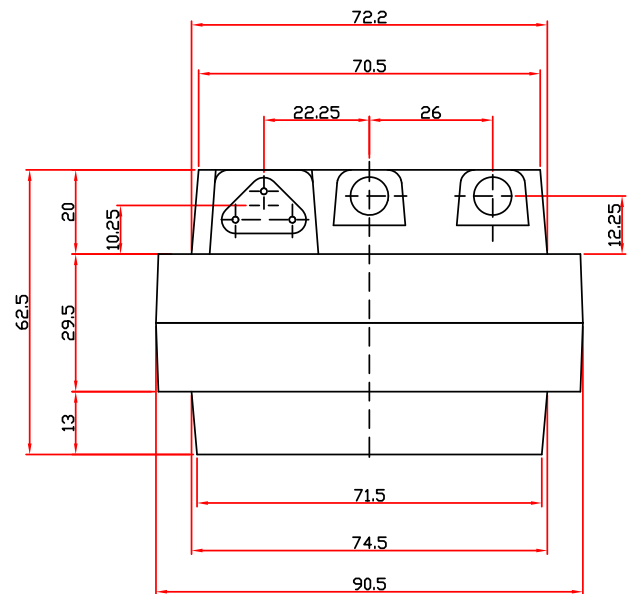
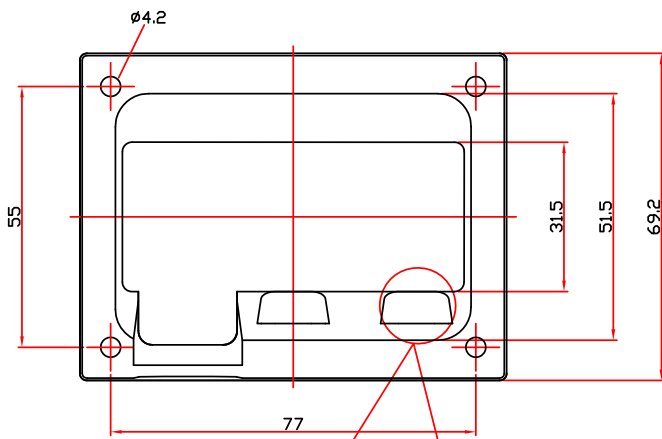

Ref.=P

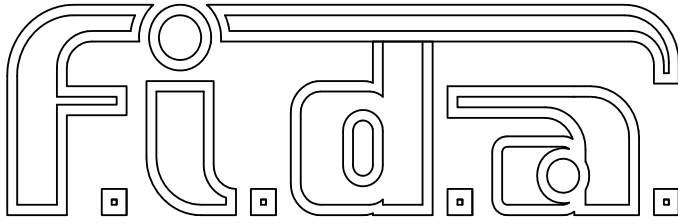

BUILT IN IGNITION TRANSFORMERS  
EINBAU ZUENDTRANSFORMATOREN  
TRANSFORMATEURS D'ALLUMAGE A INCORPORER  
TRASFORMATORI D'ACCENSIONE DA INCORPORARE

“COMPACT”

I - 31021 MOGLIANO VENETO (Treviso) - ITALY  
Via Tiziano, 14 - S.P.Z.  
Phone: +39 041 5970120 - Fax: +39 041 5970116

DISEGNO DI PROPRIETA' DELLA FIDA CON DIVIETO DI DIVULGAZIONE  
E DI RIPRODUZIONE SALVO AUTORIZZAZIONE. LA FIDA SI RISERVA  
DI APPORTARE MODIFICHE SENZA PREAVVISO.

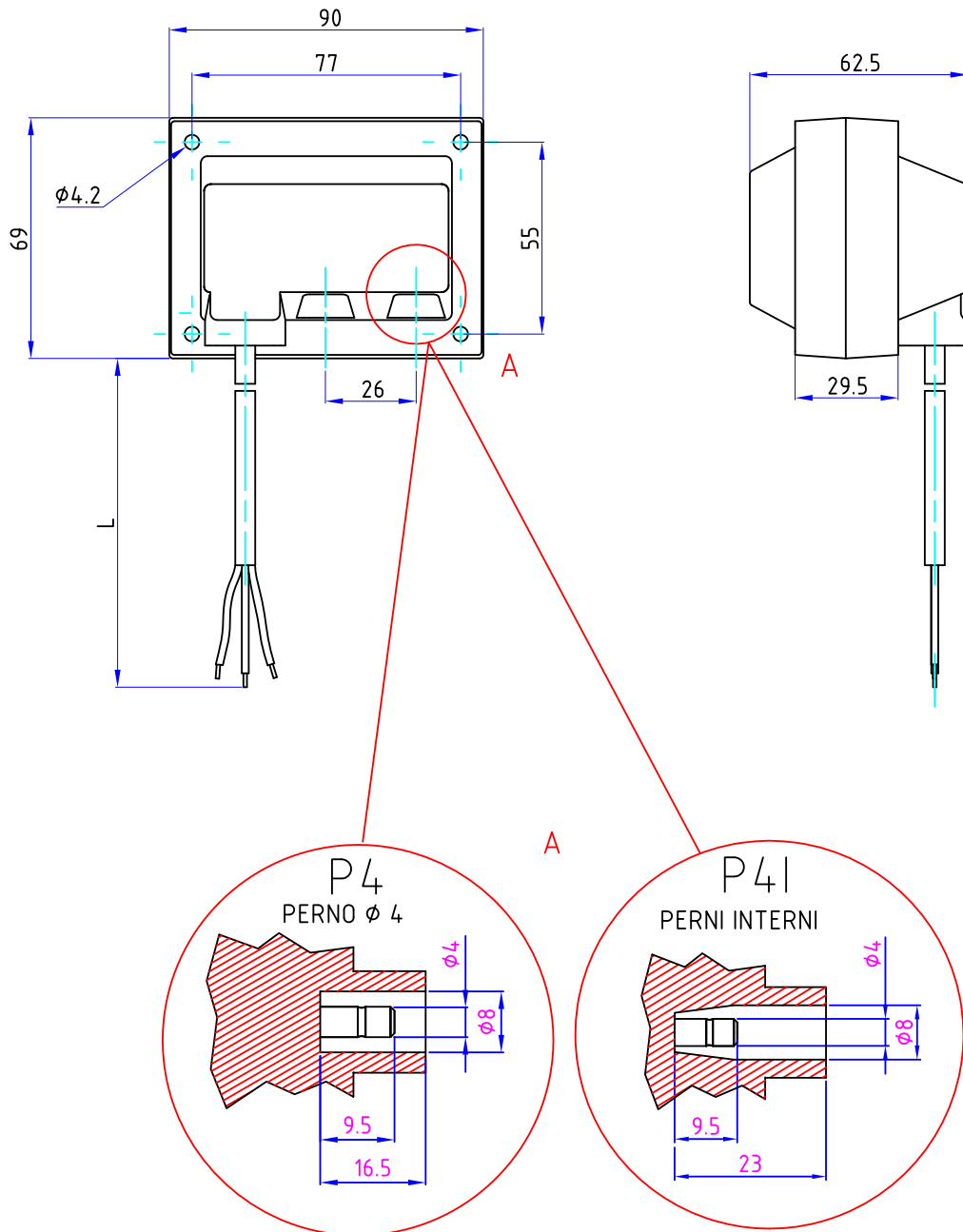

REF.PC



# FIDA

BUILT IN IGNITION TRANSFORMERS  
EINBAU ZUENDTRANSFORMATOREN  
TRANSFORMATEURS D'ALLUMAGE A INCORPORER  
TRASFORMATORI D'ACCENSIONE DA INCORPORARE

## “COMPACT”

I - 31021 MOGLIANO VENETO (Treviso) - ITALY  
Via Tiziano, 14 - S.P.Z.  
Phone: +39 041 5970120 - Fax: +39 041 5970116



DISEGNO DI PROPRIETA' DELLA FIDA CON DIVIETO DI DIVULGAZIONE  
E DI RIPRODUZIONE SALVO AUTORIZZAZIONE. LA FIDA SI RISERVA  
DI APPORTARE MODIFICHE SENZA PREAVVISO.

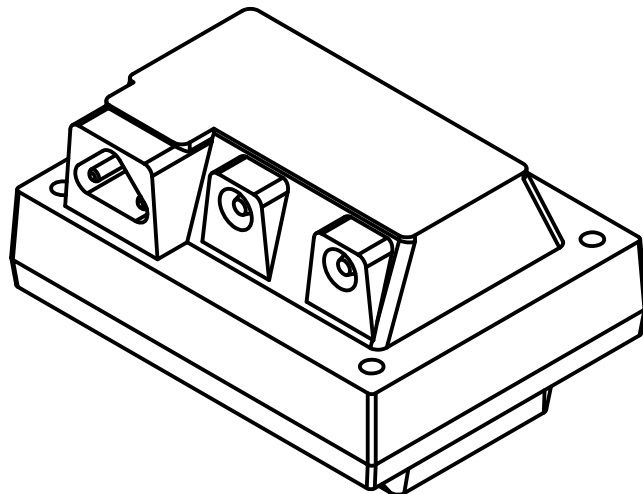
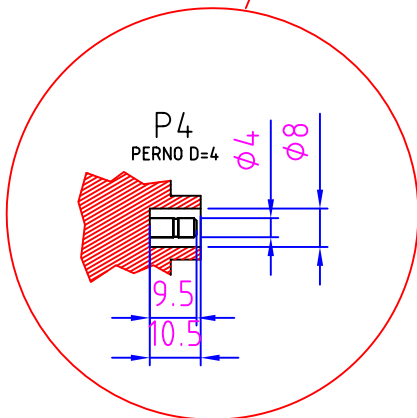
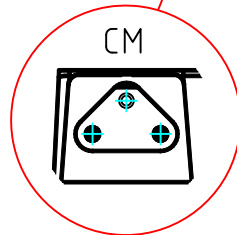
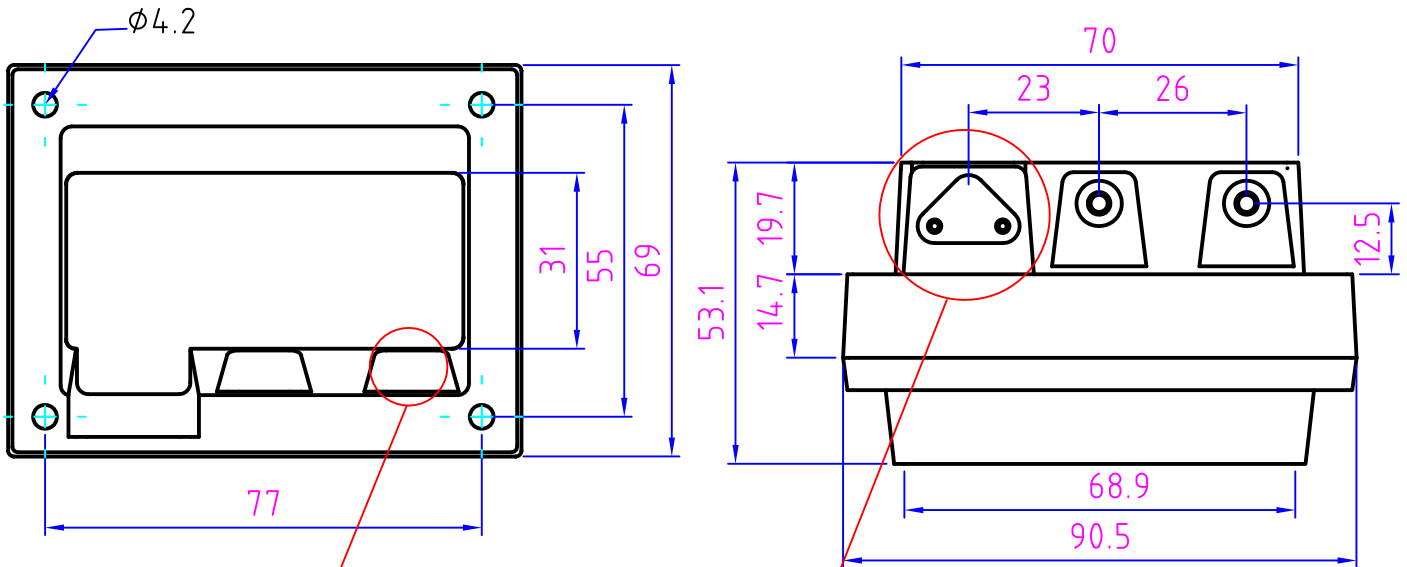

Ref.= PR









I - 31021 MOGLIANO VENETO (Treviso) - ITALY  
 Via Tiziano, 14 - S.P.Z.  
 Phone: +39 (0)41 5970120 - Fax: +39 (0)41 5970116

BUILT IN IGNITION TRANSFORMERS  
 EINBAU ZUENDTRANSFORMATOREN  
 TRASFORMATEUR D'ALLUMAGE A INCORPORER  
 TRASFORMATORI D'ACCENSIONE DA INCORPORARE

**" COMPACT "**

REF	TYPE TYP TYPE TIPO		STANDARD POWER SUPPLY STROMVERSORGUNG ALIMENTATION STANDARD ALIMENTAZIONE STANDARD			HIGH TENSION HOCHSPANNUNG HAUTE TENSION ALTA TENSIONE		MARKS ZEICHEN MARQUES MARCHI	
			V	Hz	A	V	mA		
<b>M</b>	6/20 PM		120	60	1,15	1x6000	20	CE c  US	RoHS
<b>M</b>	10/30 CM		120	60	2,7	2x5000	30	CE c  US	RoHS
<b>M</b>	8/20 PM		120	60	1,6	1x8000	20	CE c  US	RoHS
<b>G</b>	10/20 CM	100%	120	60	1,8	2x5000	20	CE c  US	RoHS

GRADO DI PROTEZIONE **IP 44** UTILIZZANDO CAVI BT E AT FIDA SOVRASTAMPATI  
 PROTECTION DEGREE: **IP 44** TOGETHER WITH FEEDING CABLE AND HIGH TENSION CABLE OVERPRINTED BY FIDA

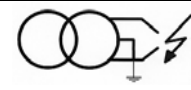
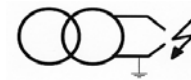
<b>CM</b>	<b>CENTRO A MASSA MIDPOINT GROUND CONNECTED</b>	
<b>PM</b>	<b>POLO A MASSA ONE POLE GROUND CONNECTED</b>	

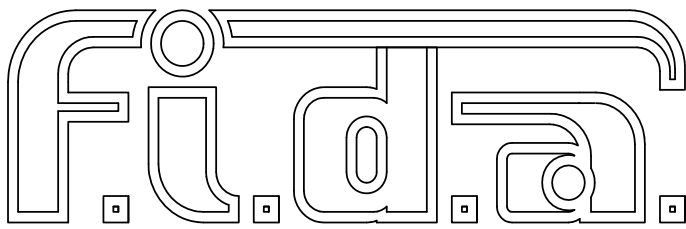

31021 MOGLIANO (TREVISO) - ITALY -  
 VIA TIZIANO, 14 - TEL. 041 / 5970120  
 FAX 041 / 5970116

BUILT IN IGNITION TRANSFORMERS  
 EINBAU ZÜNDTRANSFORMATOREN  
 TRANSFORMATEURS D'ALLUMAGE A INCORPORER  
 TRASFORMATORI D'ACCENSIONE DA INCORPORARE

“COMPACT”

DISEGNO DI PROPRIETA' DELLA FIDA CON DIVIETO DI DIVULGAZIONE  
 E DI RIPRODUZIONE SALVO AUTORIZZAZIONE. LA FIDA SI RISERVA  
 DI APPORTARE MODIFICHE SENZA PREAVVISO.

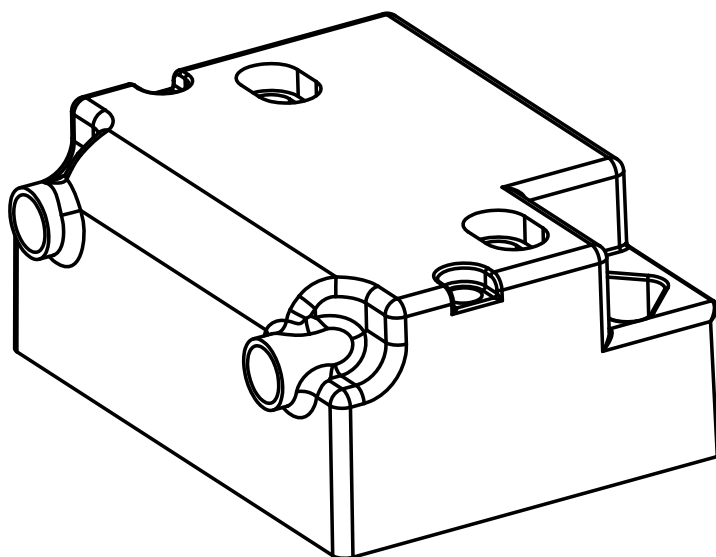
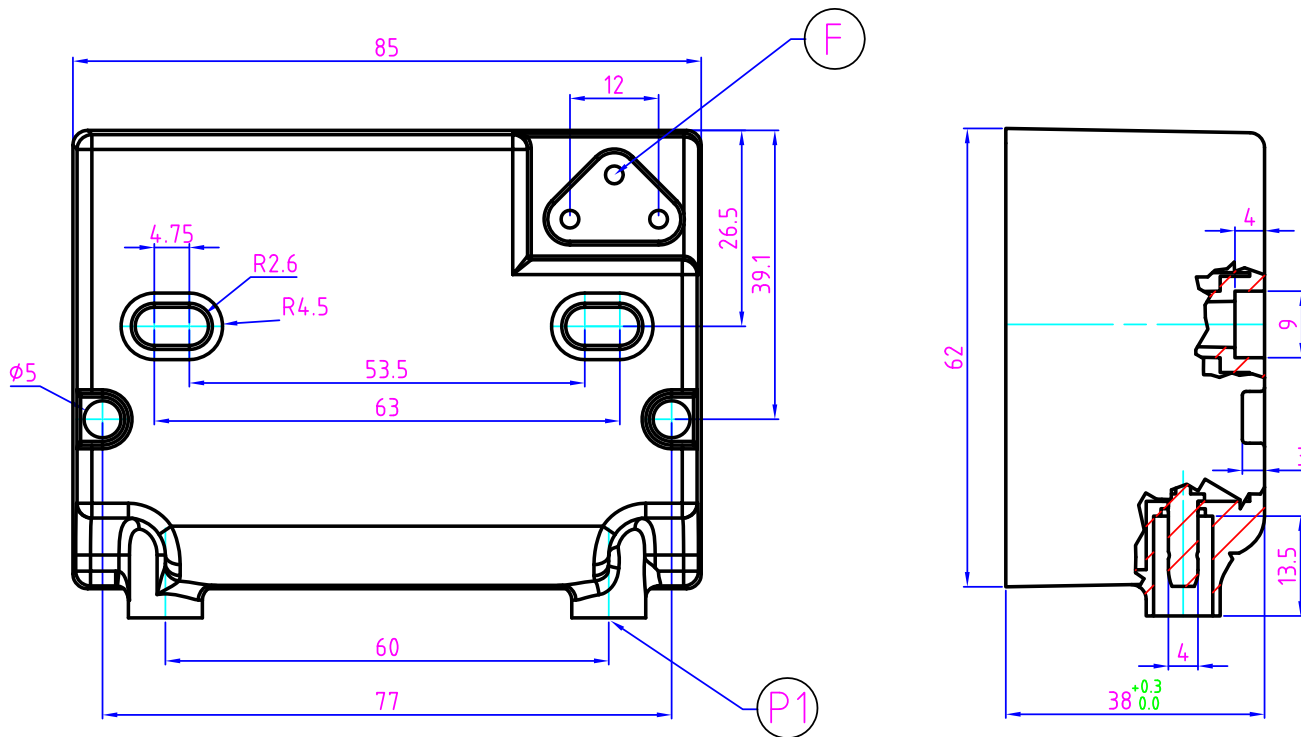

VARIATIONS

DESCRIPTION	F	P1
IS	NO	YES
IT	YES	YES
CM	YES	YES
PM	YES	NO

Electronic Transformer  
 REF: F

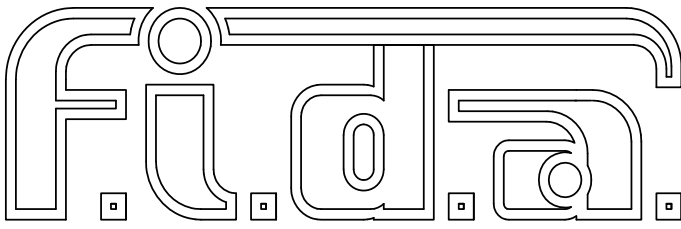

31021 MOGLIANO (TREVISO) - ITALY -  
 VIA TIZIANO, 14 - TEL. 041 / 5970120  
 FAX 041 / 5970116

BUILT IN IGNITION TRANSFORMERS  
 EINBAU ZÜNDTRANSFORMATOREN  
 TRANSFORMATEURS D'ALLUMAGE A INCORPORER  
 TRASFORMATORI D'ACCENSIONE DA INCORPORARE

“COMPACT”

DISEGNO DI PROPRIETA' DELLA FIDA CON DIVIETO DI DIVULGAZIONE  
 E DI RIPRODUZIONE SALVO AUTORIZZAZIONE. LA FIDA SI RISERVA  
 DI APPORTARE MODIFICHE SENZA PREAVVISO.

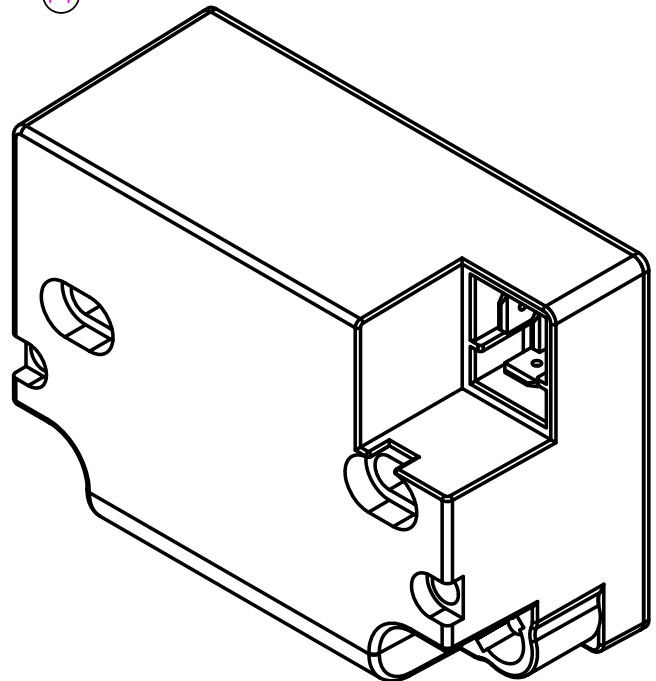
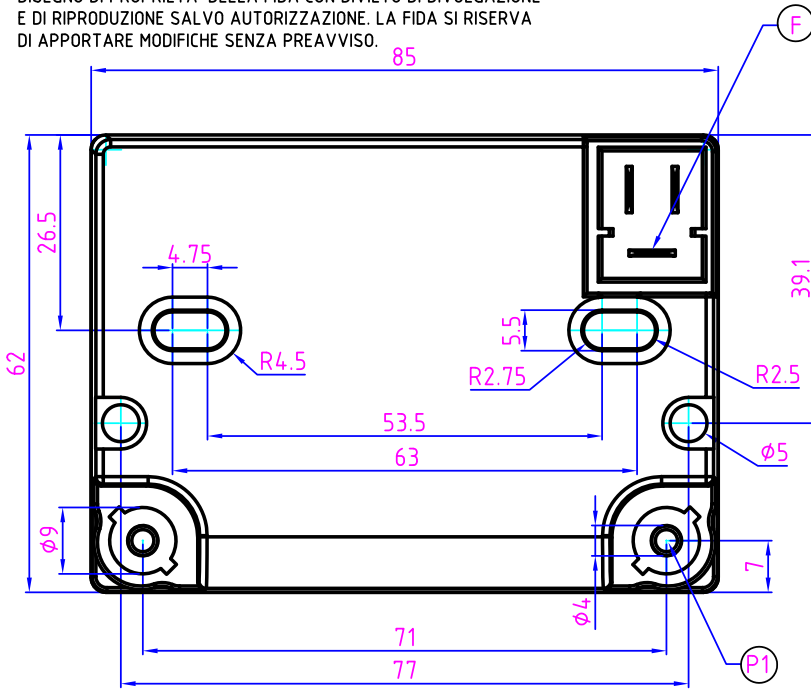

VARIATIONS

DESCRIPTION	F	P1
IS	NO	YES
IT	YES	YES
CM	YES	YES
PM	YES	NO

Electronic Transformer  
 REF: AQ

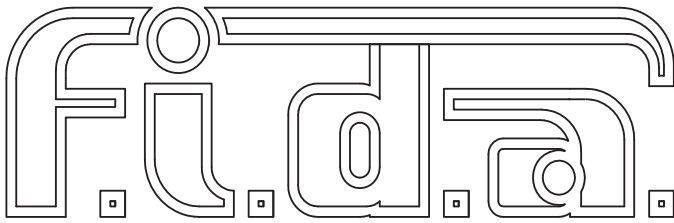

31021 MOGLIANO (TREVISO) - ITALY -  
 VIA TIZIANO, 14 - TEL. 041 / 5970120  
 FAX 041 / 5970116

BUILT IN IGNITION TRANSFORMERS  
 EINBAU ZÜNDTRANSFORMATOREN  
 TRANSFORMATEURS D'ALLUMAGE A INCORPORER  
 TRASFORMATORI D'ACCENSIONE DA INCORPORARE

“COMPACT”®

DISEGNO DI PROPRIETA' DELLA FIDA CON DIVIETO DI DIVULGAZIONE  
 E DI RIPRODUZIONE SALVO AUTORIZZAZIONE. LA FIDA SI RISERVA  
 DI APPORTARE MODIFICHE SENZA PREAVVISO.

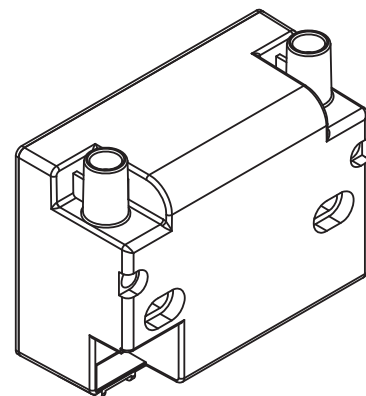
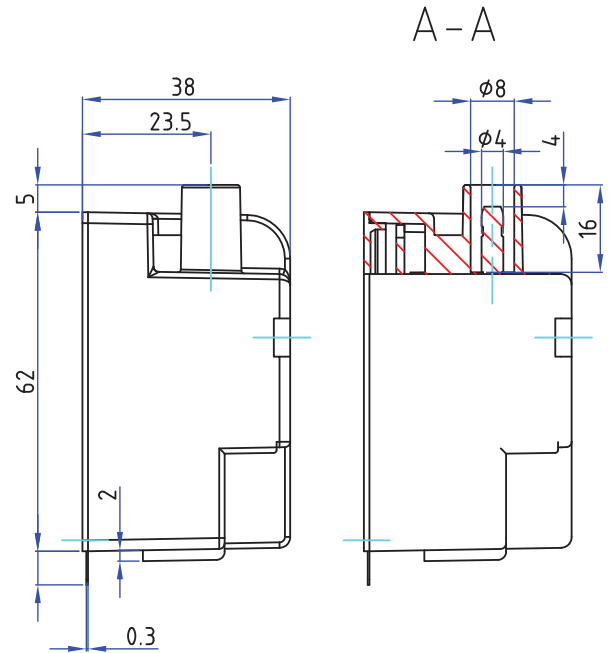
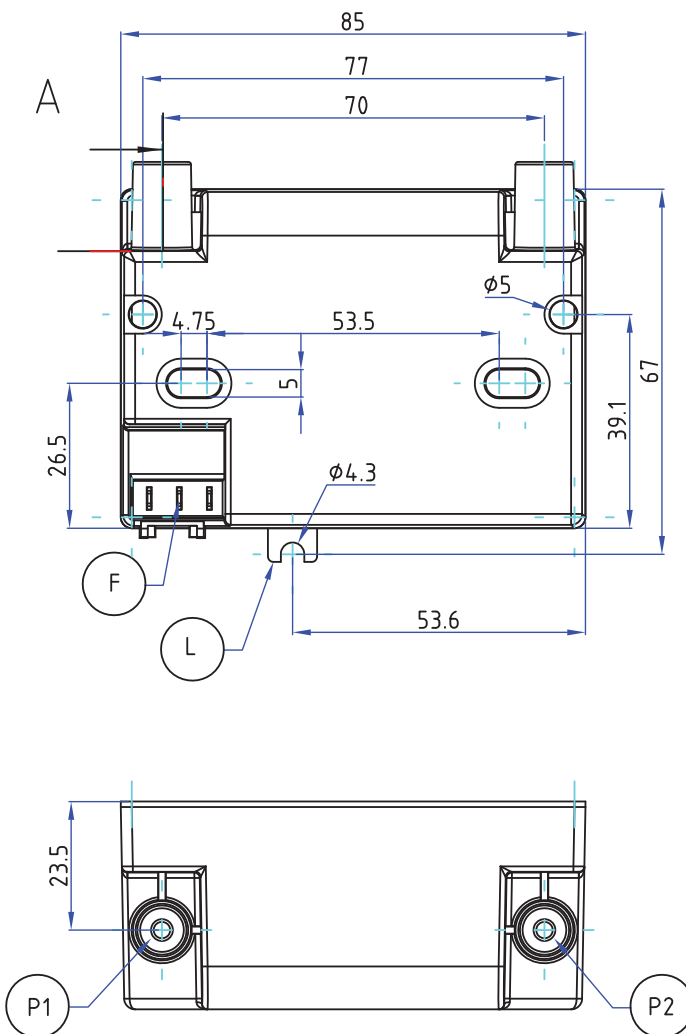

### VARIATIONS

DESCRIPTION	F	P1	P2	L
ISOLATED	NO	YES	YES	NO
ISOLATED WITH GROUND CONNECTION	YES	YES	YES	NO
ISOLATED WITH GROUND CONNECTION BY RING	NO	YES	YES	YES
ONE POLE	YES	NO	YES	NO
ONE POLE WITH GROUND CONNECTION BY RING	YES	NO	YES	YES

ELECTRONIC TRANSFORMER  
 REF.J



I - 31021 MOGLIANO VENETO (Treviso) - ITALY  
Via Tiziano, 14 - S.P.Z.  
Phone: +39 (0)41 5970120 - Fax: +39 (0)41 5970116

BUILT IN IGNITION TRANSFORMERS  
EINBAU ZUENDTRANSFORMATOREN  
TRASFORMATEUR D'ALLUMAGE A INCORPORER  
TRASFORMATORI D'ACCENSIONE DA INCORPORARE

TYPE TYPE TYPE TIPO	INTERMITTENCE EINSCHALTDAUER INTERMITTENCE INTERMITTENZA	STANDARD POWER SUPPLY STROMVERSORGUNG ALIMENTATION STANDARD ALIMENTAZIONE STANDARD			HIGH VOLTAGE HOCHSPANNUNG HAUTE TENSION ALTA TENSIONE		MARKS ZEICHEN MARQUES MARCHI	
	A 35°	V	Hz	A	V	mA		
26/30 IS	100%	230/240	50/60	0,10	1x26000	30	CE	 EN 61558-2-3 RoHS
26/30 CM	100%	230/240	50/60	0,10	2x13000	30	CE	 EN 61558-2-3 RoHS
26/30 IT	100%	230/240	50/60	0,10	1x26000	30	CE	 EN 61558-2-3 RoHS
26/30 PM	100%	230/240	50/60	0,10	1x26000	30	CE	 EN 61558-2-3 RoHS
26/35 IS	50% su 3'	230/240	50/60	0,15	1x26000	35	CE	 EN 61558-2-3 RoHS
26/35 CM	50% su 3'	230/240	50/60	0,15	2x13000	35	CE	 EN 61558-2-3 RoHS
26/35 IT	50% su 3'	230/240	50/60	0,15	1x26000	35	CE	 EN 61558-2-3 RoHS
26/40 IT	33% su 3'	230/240	50/60	0,15	1x26000	40	CE	CONFORMED EN 61558-2-3 RoHS
26/48 IT	33% su 3'	230/240	50/60	0,35	1x26000	48	CE	CONFORMED EN 61558-2-3 RoHS
26/40 PM	50% su 3'	230/240	50/60	0,15	1x26000	40	CE	 EN 61558-2-3 RoHS
28/35 PM	33%	230/240	50/60	0,15	1x28000	35	CE	CONFORMED EN 61558-2-3 RoHS
26/30 IS	100%	200	50/60	0,22	1x26000	30	CE	CONFORMED EN 61558-2-3 RoHS
26/30 PM	100%	115/120	50/60	0,35	1x26000	30	CE	CONFORMED EN 61558-2-3 RoHS
26/30 IS	100%	115/120	50/60	0,35	1x26000	30	CE	CONFORMED EN 61558-2-3 RoHS

**REF.** Altre caratteristiche su richiesta - Other types on request.

**F** GRADO DI PROTEZIONE IP 44 UTILIZZANDO CAVI BT E AT FIDA SOVRASTAMPATI  
PROTECTION DEGREE: IP 44 TOGETHER WITH FEEDING CABLE AND HIGH TENSION CABLE OVERPRINTED  
BY FIDA

**AQ**

**D**

**L** CONNESSIONE A MASSA CON VITE GROUND CONNECTED THROUGH SCREW

**CM** USCITA AT DUE POLI - CENTRO A MASSA  
TWO POLE OUTPUT HV - MIDPOINT GROUND CONNECTED

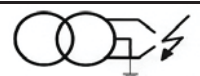

**PM** USCITA AT UN POLO - UN POLO A MASSA  
ONE POLE OUTPUT HV - ONE POLE GROUND CONNECTED

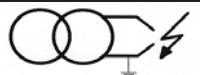

**IS** USCITA AT DUE POLI - ISOLATO  
TWO POLE OUTPUT HV - ISOLATED



**IT** USCITA AT DUE POLI - PRIMARIO CON COLLEGAMENTO DI MASSA  
TWO POLE OUTPUT HV - PRIMARY GROUND CONNECTED

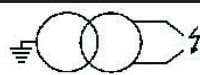



I - 31021 MOGLIANO VENETO (Treviso) - ITALY  
Via Tiziano, 14 - S.P.Z.  
Phone: +39 (0)41 5970120 - Fax: +39 (0)41 5970116

BUILT IN IGNITION TRANSFORMERS  
EINBAU ZUENDTRANSFORMATOREN  
TRASFORMATEUR D'ALLUMAGE A INCORPORER  
TRASFORMATORI D'ACCENSIONE DA INCORPORARE  
**" COMPACT "**

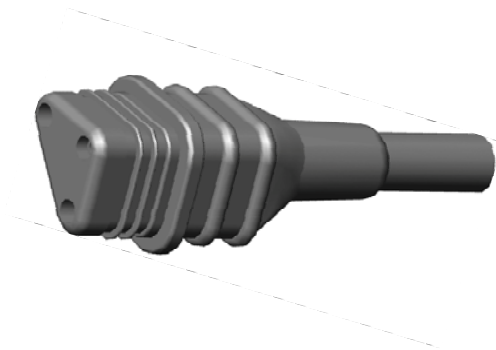

PB dritta  
STRAIGHT PLUG

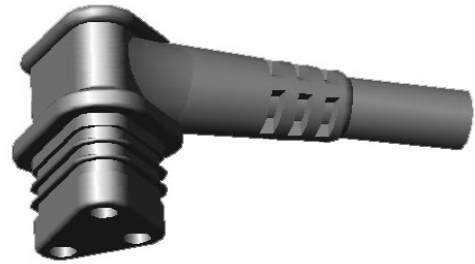

PB angolo  
ANGLED PLUG

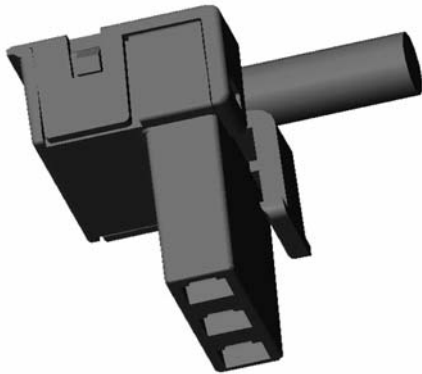

versione D -- L  
D-L PLUG

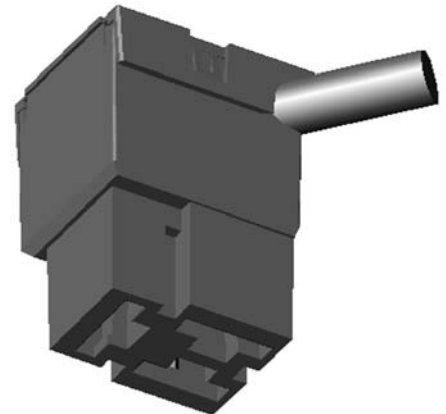

versione AQ  
AQ PLUG



ISOLAMENTO ISOLATION	CONDUTTORE CONDUCTOR	Ø mm	°C	TENSIONE NOMINALE NOMINAL VOLTAGE	TENSIONE DI PROVA TEST VOLTAGE
PVC	rame 1mm/2 copper 1 mm/2	4,4	-10 +90	7,5 KV	10 KV
		7		10 KV	15 KV
SILICON	rame 1mm/2 copper 1mm/2	5	-60 +180	5 KV	15 KV
		7		10 KV	20 KV
CPE/EPDM	carbon conductor	7	-20 +155	25 KV	35 KV
CPE/EPDM	low resistance	5	-20 +155	20 KV	30 KV
CPE/EPDM	medium resistance	7	-20 +155	25 KV	35 KV
CPE/EPDM	high resistance	5	-20 +155	20 KV	30 KV
		7		25 KV	35 KV
SILICONE	carbon/silicon low resistance	5	-50 +200	15 KV	21 KV

