

Data Sheet

Itemnumber....: 3220900209

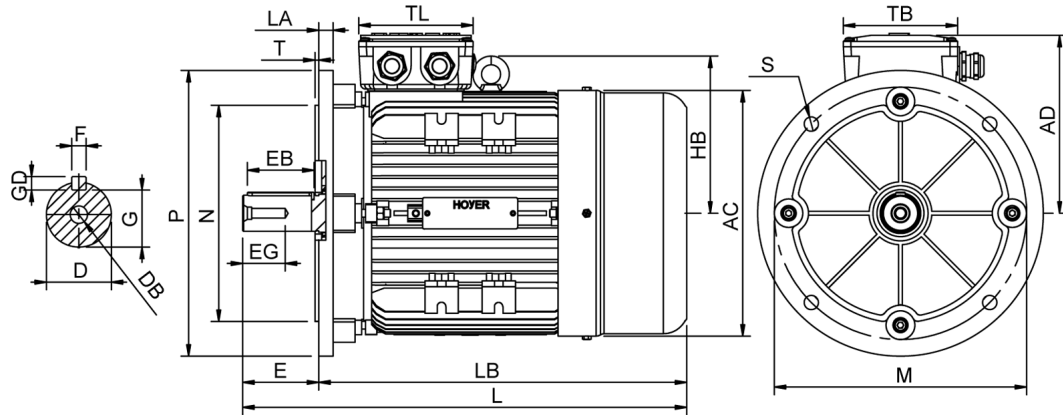

AC = 175	DB = M8	EG = 24	GD = 7	LB = 286	P = 200	TB = 100
AD = 132	E = 50	F = 8	L = 336	M = 165	S = 4-Ø12	TL = 100
D = 24	EB = 40	G = 20	LA = 10	N = 130	T = 3,50	

Version

Type.....: HMA2 90S-2
 Design.....: Induction motor
 Standard series.....: IEC 60034
 Phase / Voltage range.....: 3~ / Low

Electrical design

Efficiency.....: IE2
 Pole.....: 2
 Power at 50 Hz (kW).....: 1,50
 Hz.....: 60 (60 Hz output)
 Voltage.....: 440VY
 Winding voltage.....: 230VD/400VY 50 Hz
 Power output (kW).....: 1,74
 Duty.....: S1
 Insulation class.....: F
 Temperature rise.....: B

Mechanical design

Frame size.....: 90
 Mounting.....: B5
 Rain cap.....: No
 Protection class.....: IP55
 Cooling method.....: IC411/TEFC
 External grounding.....: Yes
 Drain hole.....: Yes
 Frame material.....: Aluminium
 Material approval.....: None
 Shaft.....: IEC Standard
 Key.....: Closed key
 Balancing.....: Half key balancing
 Vibration class.....: Grade-A
 Weight (kg).....: 15,0

Bearing

DE Bearing.....: 6205-ZZ/C3
 NDE Bearing.....: 6205-ZZ/C3
 Fixed bearing.....: DE

Terminal box

Tbox position.....: Top
 Cable entry direction.....: Right (from DE)
 Cable entry
 Main.....: 1 x M20x1,5
 Ø8-13mm metal
 1 x M20x1,5
 Accessory.....: Metal blindcap
 Terminal board thread.....: 6-M4

Environment condition

Ambient temp. min. (°C)..: -20
 Ambient temp. max. (°C)..: 45
 Altitude (mtr up to).....: 1000

Test values

Rotor inertia (kgm²).....: 0,0018
 Noise level (dB(A)).....: 66
 No load current (A).....: 1,70
 Winding resist. (ohm).....: 3,79
 Starting time (sec.).....: 0,00
 Temp. rise winding (K).....: 46
 Temp. rise surface (K).....: 39

Motor protection

Thermal protection main.....: PTC 3x 155 dgr
 Thermal protection second..: None
 Space heater.....: None
 Temperature detector.....: No
 SPM.....: No
 IR wire.....: No
 Tropical insulation.....: Yes

Explosion protection

According to.....: None
 Type of protection.....: None

General

Direction of rotation.....: CW
 Painting.....: RAL 9005
 Nameplate.....: Multivoltage + VFD
 Special packing.....: No
 Special requirements.....: No

Rated power (kW)	1,50	1,46	1,80	1,74
Frequency (Hz)	50	50	60	60
Voltage (V)	230 400	220 380	280 480	440
Connection	D Y	D Y	D Y	Y
Full load current (A)	5,55 3,20	5,75 3,30	5,55 3,20	3,30
Speed (rpm)	2890	2890	3460	3460
Power factor cos(phi)	0,83	0,84	0,83	0,83
Efficiency, 100/75/50 (%)	81,3/ 82,0 /80,6	81,3/ 82,0 /80,6	81,3/ 82,0 /80,6	80,0/ 80,8 /79,2
Ist/In	7,05	6,20	7,05	6,50
Full load torque (Nm)	4,95	4,80	4,95	4,80
Tst/Tn	3,00	2,80	3,00	2,60
Tmax/Tn	3,50	3,25	3,50	3,05
Duty	S1	S1	S1	S1
Ambient temp. (°C)	40	45	40	45