



Oil Burner Controls

LMO14...
LMO24...
LMO44...

Microcontroller-based oil burner controls for the startup, supervision and control of forced draft oil burners in intermittent operation. Maximum oil throughput up to 30 kg/h, also above 30 kg/h on some versions.

The LMO14, LMO24, LMO44 and this Data Sheet are intended for use by OEMs which integrate the burner controls in their products.

Use, features

Use

The LMO are designed for the startup and supervision of 1- or 2-stage forced draft oil burners in intermittent operation. Yellow-burning flames are supervised with photo resistive detectors QRB1 / QRB3 or yellow flame detector QRB4, blue-burning flames with blue flame detector QRC1. In terms of housing dimensions, electrical connections and flame detectors, the LMO are identical with the LOA oil burner controls.

- Applications in accordance with EN 267: Automatic forced draft burners for liquid fuels
- Type-tested and approved in accordance with DIN EN 298

Features

- LMO44 for use with stationary direct-fired air heaters
- Undervoltage detection
- Electrical remote reset
- Bridging contact for oil preheater
- Monitoring of time for oil preheater
- Accurate and reproducible control sequence thanks to digital signal handling
- Controlled intermittent operation after 24 hours of continuous operation
- Restart limitation
- Multicolor indication of fault status and operational status messages

Supplementary documentation

Product type	Type of documentation	Documentation number
LMO	Environmental declaration	E7130 *)
ACS410	Software documentation	J7352
OCI400	Data sheet	N7614
QRB1 / QRB3	Data sheet	N7714
QRB4	Data sheet	N7720
QRC1	Data sheet	N7716

*) On request

Warning notes



To avoid injury to persons, damage to property or the environment, the following warning notes must be observed!

Do not open, interfere with or modify the unit!

- All activities (mounting, installation and service work, etc.) must be performed by qualified staff
- Before making any wiring changes in the connection area, completely isolate the plant from mains supply (all-polar disconnection). Ensure that the plant cannot be inadvertently switched on again and that it is indeed dead. If not observed, there is a risk of electric shock hazard
- Ensure protection against electric shock hazard by providing adequate protection for the burner control's connection terminals. If this is not observed, there is a risk of electric shock
- Each time work has been carried out (mounting, installation, service work, etc.), check to ensure that wiring is in an orderly state and make the safety checks as described in «Commissioning notes». If not observed, there is a risk of impairment of safety functions and of electric shock hazard
- Press the lockout reset button / operation button or the AGK20 lockout reset button extension only manually (applying a force of no more than 10 N) without using any tools or pointed objects. If not observed, there is a risk of impairment of safety functions and of electric shock hazard
- Fall or shock can adversely affect the safety functions. Such units must not be put into operation, even if they do not exhibit any damage. If not observed, there is a risk of impairment of safety functions and of electric shock hazard
- Risk of damage to the switching contacts!
If the external primary fuse (Si) is blown due to overload or short-circuit at the terminals, the LMO must be replaced.
- When replacing LOA26 or LOA36, any ARK21 remote lockout reset module or similar modules fitted in the burner or boiler must be removed.
If this is not observed, there is a risk of loss of safety functions and a risk of electric shock



Mounting notes

Ensure that the relevant national safety regulations are complied with.

Installation notes

- Always run the high-voltage ignition cables separately while observing the greatest possible distances to the unit and to other cables
- Install switches, fuses, earthing, etc., in compliance with local regulations
- Risk of damage to the switching contacts!
If the external primary fuse (Si) is blown due to overload or short-circuit at the terminals, the LMO must be replaced.
- Ensure that the maximum permissible amperages will not be exceeded (refer to «Technical data»)
- Do not feed external mains voltage to the control outputs of the unit. When testing the components controlled by the burner control (fuel valves, etc.), the LMO may never be plugged in
- Do not mix up live and neutral conductors

Electrical connection of the flame detectors

It is important to achieve practically disturbance- and loss-free signal transmission:

- Never run the detector cable together with other cables
 - Line capacitance reduces the magnitude of the flame signal
 - Use a separate cable
- Observe the maximum permissible lengths of the detector cables (refer to «Technical data»)
- Earth the burner in compliance with the relevant regulations; earthing the boiler alone does not suffice

Commissioning notes

When commissioning the plant or when doing maintenance work, make the following safety checks:

	Safety check	Anticipated response
a)	Burner startup with flame detector darkened	Non-alterable lockout at the end of the safety time (TSA)
b)	Burner startup with flame detector exposed to extraneous light	Non-alterable lockout within 40 seconds
c)	Burner operation with simulated loss of flame; for that purpose, darken the flame detector during operation and maintain that state	Restart followed by the non-volatile lockout at the end of safety time (TSA)



Applied directives:

- Low-voltage directive 2014/35/EC
- Directive for pressure devices 2014/68/EC
- Electromagnetic compatibility EMC (immunity) *) 2014/30/EC

*) The compliance with EMC emission requirements must be checked after the burner control is installed in equipment

Compliance with the regulations of the applied directives is verified by the adherence to the following standards / regulations:

- Automatic burner control systems for burners and appliances burning gaseous or liquid fuels DIN EN 298
- Safety and control devices for burners and appliances burning gaseous and/or liquid fuels — General requirements DIN EN 13611
- Automatic electrical controls for household and similar use Part 2-5: Particular requirements for automatic electrical burner control systems DIN EN 60730-2-5

The relevant valid edition of the standards can be found in the declaration of conformity!



Note on **DIN EN 60335-2-102**

Household and similar electrical appliances - Safety Part 2-102:

Particular requirements for gas, oil, and solid-fuel burning appliances having electrical connections. The electrical connections of the LMO and the AGK11 comply with the requirements of EN 60335-2-102.



EAC Conformity mark (Eurasian Conformity mark)



UKCA conformity mark (UK compliance)



China RoHS

Hazardous substances table:

<http://www.siemens.com/download?A6V10883536>



Service notes

The service adapters can only be used for a short time. They may only be used in supervised operation by qualified staff.

Life cycle

Burner controls has a designed lifetime* of 250,000 burner startup cycles which, under normal operating conditions in heating mode, correspond to approx. 10 years of usage (starting from the production date given on the type field). This lifetime is based on the endurance tests in the standard EN 298. A summary of the conditions has been published by the European Control Manufacturers Association (Afecon) (www.afecor.org).

The designed lifetime is based on use of the burner controls according to the manufacturer's Data Sheet. After reaching the designed lifetime in terms of the number of burner startup cycles, or the respective time of usage, the burner control is to be replaced by authorized personnel.

* The designed lifetime is not the warranty time specified in the Terms of Delivery

Disposal notes

The LMO contains electrical and electronic components and must not be disposed of together with domestic waste. Local and currently valid legislation must be observed.

Mechanical design

The housing is made of impact-proof, heat-resistant and flame-retarding plastic. It is of plug-in design and engages audibly in the base. Burner controls LMO are designed in black plastic.

The housing accommodates the

- microcontroller for the control sequence and the print relays for load control
- electronic flame signal amplifier
- lockout reset button with its integrated multicolor signal lamp (LED) for operational status and fault status messages and the socket for connecting the OCI400 interface or the AGK20 lockout reset button extension

Indication and diagnostics

- Multicolor indication of operational status and fault status messages
- Transmission of operational status and fault status messages and detailed service information via additional OCI400 interface and ACS410 PC software

Type summary

Article no.	Type reference	Mains voltage	Fuel valve stages	Burner capacity	1)	Remote reset	Times						Comparable type of LOA 4)
							tw max.	t1 / t1' min.	TSA max.	t3 min.	t3n max.	t4 min.	
Standard versions													
BPZ:LMO14.111C2	LMO14.111C2	AC 230 V	1	<30 kg/h	•	•	2,5 s	15 / 16 s	10 s	15 s	10 s	---	LOA24.171B27 LOA26.171B27 ²⁾ LOA36.171A27 ²⁾
BPZ:LMO14.113C2	LMO14.113C2	AC 230 V	1	<30 kg/h	•	•	2,5 s	15 / 16 s	10 s	15 s	3 s	---	LOA24.173A27 ³⁾
BPZ:LMO24.111C2	LMO24.111C2	AC 230 V	2	<30 kg/h	•	•	2,5 s	15 / 16 s	10 s	15 s	10 s	15 s	LOA24.171B27 LOA26.171B27 ²⁾ LOA36.171A27 ²⁾
Suitable for flash-steam generators													
BPZ:LMO24.111C1	LMO24.111C1	AC 120 V	2	<30 kg/h	•	•	2,5 s	15 / 16 s	10 s	15 s	10 s	15 s	LOA24.171B17
BPZ:LMO24.011C2	LMO24.011C2	AC 230 V	2	<30 kg/h	•	•	2,5 s	5 / 6 s	10 s	5 s	10 s	15 s	LOA24.571C27
Suitable for use with air heaters (WLE)													
BPZ:LMO24.255C2	LMO24.255C2	AC 230 V	2	< / >30 kg/h	•	•	2,5 s	25 / 26 s	5 s	25 s	5 s	15 s	---
BPZ:LMO44.255C2	LMO44.255C2	AC 230 V	2	< / >30 kg/h	•	•	2,5 s	25 / 26 s	5 s	25 s	5 s	5 s	LOA44.252A27

Legend

TSA Ignition safety time

tw Waiting time

t1 Prepurge time

t1' Purge time

t3 Preignition time

t3n Postignition time

t4 Interval from flame signal to release of fuel valve 2 (BV2)

1) Bridging contact for oil preheater

2) No actuator (SA) function

3) In case of replacement, ignition transformer must be rewired from terminal 7 (LOA) to terminal 6 (LMO)

4) LMO can replace LOA, but the instructions given in the Data Sheet, other technical documentation and the specification must be followed

Accessories (must be ordered separately)

Test adapter

Test adapter **KF8833**

Article no.: **BPZ:KF8833**

- For checking the functions of burner controls on the burner
- With signal lamps for program indication
- With one pair of jacks for measuring the flame detector current



Connection accessories for small burner controls

Plug-in base **AGK11**

Article no.: **BPZ:AGK11**

To connect the small-capacity burner controls to the burner plant.

See data sheet N7201.



Cable holders **AGK66**

Article no.: **BPZ:AGK66**

For plug-in base AGK11.

See data sheet N7201.



Cable gland holder **AGK65**

Article no.: **BPZ:AGK65**

- Cable gland holder for AGK11 plug-in base
- Pg11

See data sheet N7201.



Cable gland holder **AGK65.1**

Article no.: **BPZ:AGK65.1**

- Cable gland holder for AGK11 plug-in base
- M16 x 1.5

See data sheet N7201.



Cable strain relief elements **AGK67**

Article no.: **BPZ:AGK67**

For plug-in base AGK11.

See data sheet N7201.



Accessories (must be ordered separately) (cont'd)

Flame detectors

Photo resistive detectors **QRB1** (for replacement units only)
See data sheet N7714



Photo resistive detectors **QRB3**
See data sheet N7714.



Yellow flame detector **QRB4**
See data sheet N7720.



Blue-flame detectors **QRC1**
See data sheet N7716.

Frontal illumination:



Lateral illumination:



Service tools

Optical interface **OCI400**

Article no.: **BPZ:OCI400**

- Optical interface between burner control and PC
- Facilitates viewing and recording setting parameters on site in connection with the ACS410 PC software

See data sheet N7614.



PC software **ACS410**

Article no.: **BPZ:ACS410**

PC software for setting the parameters and for visualizing the burner controls.

See software documentation J7352.

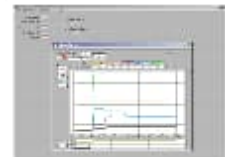

Others

Extension of lockout reset button **AGK20**



Technical data

General unit data

Mains voltage	AC 230 V +10 % / -15 % AC 120 V +10 % / -15 %
Mains frequency	50...60 Hz \pm 6 %
External primary fuse (Si)	6.3 A (slow)



Caution!

Risk of damage to the switching contacts!

If the external primary fuse (Si) is blown due to overload or short-circuit at the terminals, the LMO must be replaced.

Power consumption	12 VA
Perm. mounting orientation	Optional
Weight	Approx. 200 g
Dimensions	Refer to chapter <i>Dimensions</i>
Safety class	I (burner control with plug-in base)
Degree of protection	IP40 (to be ensured through mounting)



Note

The burner or boiler manufacturer must ensure degree of protection IP40 through adequate installation of the LMO.

Creepage distances and air gaps	<ul style="list-style-type: none"> • Overvoltage category III • Rated surge voltage 4 kV at 230 V AC • Pollution degree 2 • Up to 2,000 m above sea level
Cable lengths	
• QRB1 / QRB3	Max. 10 m at 100 pF/m (laid separately)
• QRB4	Max. 3 m at 100 pF/m (laid separately)
• QRC1	Max. 10 m at 100 pF/m (laid separately)
Detector cable laid separately	Max. 10 m
Remote reset laid separately	Max. 20 m

Perm. current at $\cos\phi \geq 0.6$	LMO14	LMO24	LMO44
Terminal 1	Max. 5 A	Max. 5 A	Max. 5 A
Terminals 3 and 8	Max. 3 A	Max. 3 A	Max. 3 A
Terminals 4 and 5	Max. 1 A	Max. 1 A	Max. 1 A
Terminal 6	Max. 1 A	Max. 2 A	Max. 2 A
Terminal 10	Max. 1 A	Max. 1 A	Max. 1 A

Technical data (cont'd)

Environmental conditions

Storage

Climatic conditions
Mechanical conditions
Temperature range
Humidity

EN 60721-3-1:1997
Class 1K3
Class 1M2
-20...+60 °C
<95 % r.h.

Transport

Climatic conditions
Mechanical conditions
Temperature range
Humidity

EN 60721-3-2:1997
Class 2K2
Class 2M2
-20...+60 °C
<95 % r.h.

Operation

Climatic conditions
Mechanical conditions
Temperature range
• LMO14 / LMO24
• LMO44
Humidity
Installation altitude

EN 60721-3-3:1995+A2:1997
Class 3K3
Class 3M3
-5...+60 °C
-20...+60 °C
<95 % r.h.
Max. 2,000 m above sea level



Attention!

Condensation, formation of ice and ingress of water are not permitted! If this is not observed, there is a risk of loss of safety functions and a risk of electric shock.

Technical data (cont'd)

Flame supervision with QRB1 / QRB3 / QRB4 or QRC1

	Detector current required (with flame)	Perm. detector current (without flame)	Possible detector current with flame (typically)
QRB1 ¹⁾	Min. 45 µA	Max. 5,5 µA	100 µA
QRB3 ¹⁾	Min. 45 µA	Max. 5,5 µA	100 µA
QRB4 ¹⁾	Min. 45 µA	Max. 5,5 µA	70 µA
QRC1 ¹⁾	Min. 45 µA	Max. 5,5 µA	70 µA

- ¹⁾ The values given in the table above only apply under the following conditions:
- Mains voltage depending on execution AC 120 V or AC 230 V
 - Ambient temperature 23 °C

Green signal lamp (LED) for indication of operating state

	Detector current in operation:	Detector current in operation:
	<ul style="list-style-type: none"> • Flame signal instable • - Green signal lamp (LED) flashing 	<ul style="list-style-type: none"> • Flame signal stable • Green signal lamp (LED) steady on
QRB1 ¹⁾	<45 µA	>45 µA
QRB3 ¹⁾	<45 µA	>45 µA
QRB4 ¹⁾	<45 µA	>45 µA
QRC1 ¹⁾	<45 µA	>45 µA

- ¹⁾ The values given in the table above only apply under the following conditions:
- Mains voltage depending on execution AC 120 V or AC 230 V
 - Ambient temperature 23 °C

Measuring circuit for detector current

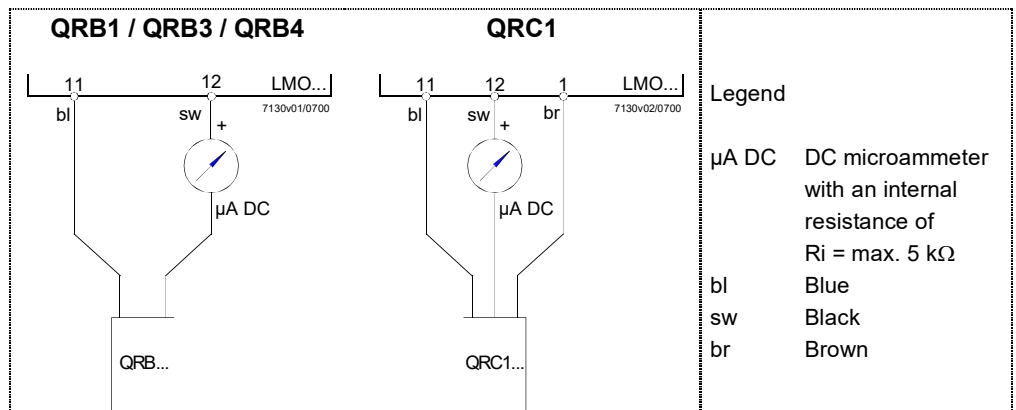

As an alternative to detector current measurement, the Interface OCI400 with PC software ACS410 can be used. In that case, the DC microammeter is not required.



Note!

QRB4 cable connection!

- Connect the blue QRB4 cable to terminal 11.
- Connect the black QRB4 cable to terminal 12.
- Otherwise the QRB4 will not function.

Function

Preconditions for startup	<ul style="list-style-type: none"> • Burner control is reset • Reset button «EK1» or «EK2» not used • All contacts in the line are closed, heat demand • No undervoltage • Flame detector is darkened and there is no extraneous light
Undervoltage	<ul style="list-style-type: none"> • Safety shutdown from the operating position takes place should mains voltage drop below about AC 165 V (with $U_N = AC 230 V$) or AC 75 V (with $U_N = AC 120 V$) • Restart is initiated when mains voltage exceeds about AC 175 V (with $U_N = AC 230 V$) or AC 95 V (with $U_N = AC 120 V$)
Time supervision oil preheater	If the oil preheater's release contact does not close within 10 minutes, a non-alterable lockout takes place.
Controlled intermittent operation	After no more than 24 hours of continuous operation, the burner control will initiate automatic controlled shutdown followed by a restart.
Control sequence in the event of fault	If a non-alterable lockout occurs, the outputs for the fuel valves, the burner motor and the ignition equipment are always immediately deactivated (<1 second). In the event of a non-volatile lockout, the LMO remains locked and the signal lamp (LED) lights up red permanently. The burner control can immediately be reset. This state is also maintained in the case of mains failure.

Cause	Response
Mains failure	Restart
Voltage below undervoltage threshold	Safety shutdown, followed by restart
Extraneous light during prepurge time (t1), 5 s before fuel valve (BV1) release	Non-alterable lockout at the end of the prepurge time (t1)
Extraneous light during waiting time (tw)	Start prevention, a non-alterable lockout occurs after a maximum of 40 seconds
No flame at the end of safety time (TSA)	Non-alterable lockout at the end of the safety time (TSA), blink code 2, see <i>Control sequence</i>
Loss of flame during operation	Maximum of 3 restarts, then a non-volatile lockout occurs
Oil preheater's release contact does not close within 10 minutes	Non-alterable lockout

Resetting the burner control	After a non-alterable lockout, a reset can be carried out immediately. Press and hold the lockout reset button for about 1 second (<3 seconds). The LMO can be reset only when all contacts in the line are closed and there is no undervoltage.
Ignition program with LMO14.113x2 and LMO24.113x2	If the flame is lost during the safety time (TSA), the burner will be reignited before the end of the safety time (TSA). This means that several ignition attempts can be made during safety time (TSA) (see <i>Control sequence</i>).
Restart limitation	If the flame is lost during operation, a maximum of 3 restarts can be performed. If the flame is lost for the fourth time during operation, a non-volatile lockout will be initiated. The restart counter is restarted each time a controlled startup by the control thermostat or pressurestat (R) takes place.

Operation

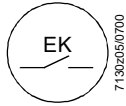

Lockout reset button «EK» is the key operating element for resetting the burner control and for activating / deactivating the diagnostic functions.

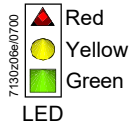

The multicolor signal lamp (LED) in the lockout reset button is the key indicating element for both visual diagnostics and interface diagnostics.

Both «EK» and LED are located under the transparent cover of the lockout reset button.

There are 2 diagnostic choices:

1. Visual diagnostics: Operational status indication or diagnostics of the cause of fault.
2. Interface diagnostics: With the help of the interface OC1400 and PC software ACS410 or flue gas analyzers of different makes.

Visual diagnostics:

In normal operation, the different operating states are indicated in the form of color codes according to the color code table given below.

Operational status indication

During startup, status indication takes place according to the following table:

Color code table for multicolor signal lamp (LED)		
Status	Color code	Color
Waiting time «tw», other waiting states	○	Off
Oil preheater on	●	Yellow
Ignition phase, ignition controlled	○ ● ○ ● ○ ● ○ ● ○ ● ○	Flashing yellow
Operation, flame o.k.	■	Green
Operation, flame not o.k. (when detector current drops below the recommended level for reliable operation)	○ ■ ○ ■ ○ ■ ○ ■ ○	Flashing green
Extraneous light on burner startup	■ ▲ ■ ▲ ■ ▲ ■ ▲ ■ ▲ ■	Green-red
Undervoltage	● ▲ ● ▲ ● ▲ ● ▲ ● ▲ ● ▲	Yellow-red
Fault, alarm	▲	Red
Error code output (refer to «Error code table»)	○ ▲ ○ ▲ ○ ▲ ○ ▲ ○ ▲ ○	Flashing red
Interface diagnostics	▲ ▲ ▲ ▲ ▲ ▲ ▲ ▲ ▲ ▲ ▲ ▲ ▲ ▲ ▲ ▲	Red flicker light

Legend

..... Steady on
○ Off

▲ Red
● Yellow
■ Green

Operation, display, diagnostics (cont'd)

Diagnostics of the cause of fault

After a non-volatile lockout, the signal lamp (LED) lights up red. In that condition, the visual diagnostics of the cause of fault according to the error code table can be activated by pressing the lockout reset button for more than 3 seconds. Pressing the reset button again for at least 3 seconds, the interface diagnostics will be activated. Interface diagnostics works only if the AGK20... lockout reset button extension is not fitted. If, by accident, interface diagnostics has been activated, in which case the slightly red light of the signal lamp flickers, it can be deactivated by pressing again the lockout reset button for at least 3 seconds. The instant of switching over is indicated by a yellow light pulse.

The following sequence activates the diagnostics of the cause of fault:

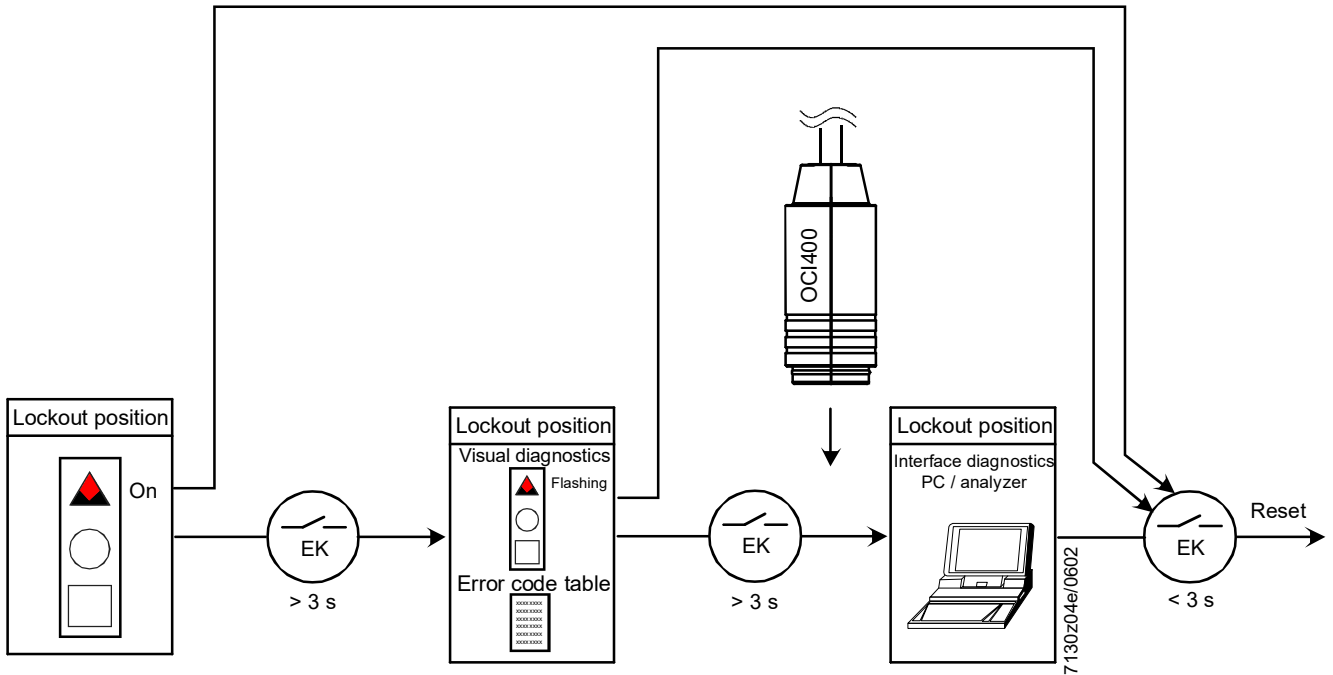

Error code table of multicolor signal lamp (LED)

Red blink code of signal lamp	Alarm at terminal 10	Possible cause
2 blinks	On	No establishment of flame at the end of safety time (TSA) <ul style="list-style-type: none"> Faulty or soiled fuel valves Faulty or soiled flame detector Poor adjustment of burner, no fuel Faulty ignition equipment
3 blinks	On	Free
4 blinks	On	Extraneous light on burner startup
5 blinks	On	Free
6 blinks	On	Free
7 blinks	On	Too many losses of flame during operation (restart limitation) <ul style="list-style-type: none"> Faulty or soiled fuel valves Faulty or soiled flame detector Poor adjustment of burner
8 blinks	On	Time supervision oil preheater
9 blinks	On	Free
10 blinks	Off	Wiring fault or internal fault, fault output contacts, faults that cannot be detected, such as simultaneous faults, other faults

During the time the cause of fault is diagnosed, the control outputs are dead

- The burner remains shut down
- the external fault indicator remains de-energized
- Fault status signal (alarm) at terminal 10, according to the error code table

The diagnostics of the cause of fault is quit and the burner switched on again by resetting the burner control. Press the lockout reset button for about 1 second (<3 seconds).

Connection diagram and internal diagram LMO14

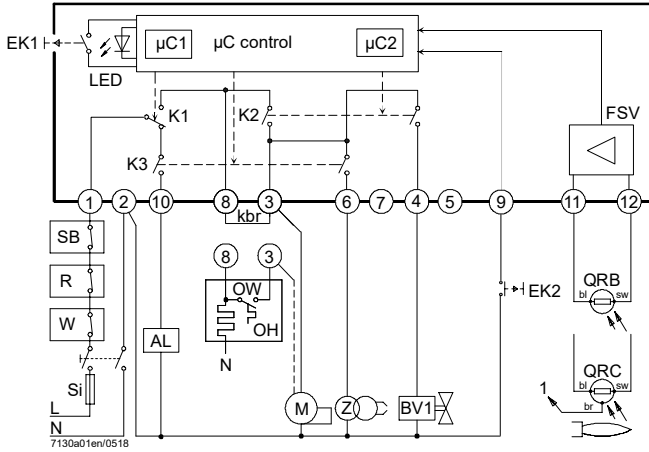

Control sequence LMO14

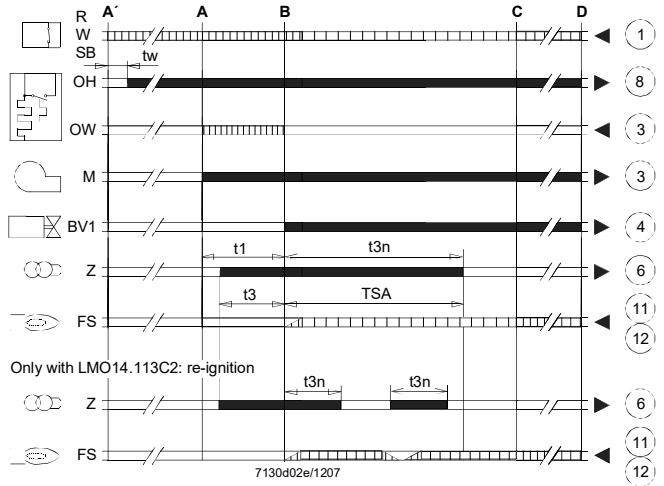

Connection diagram and internal diagram LMO24

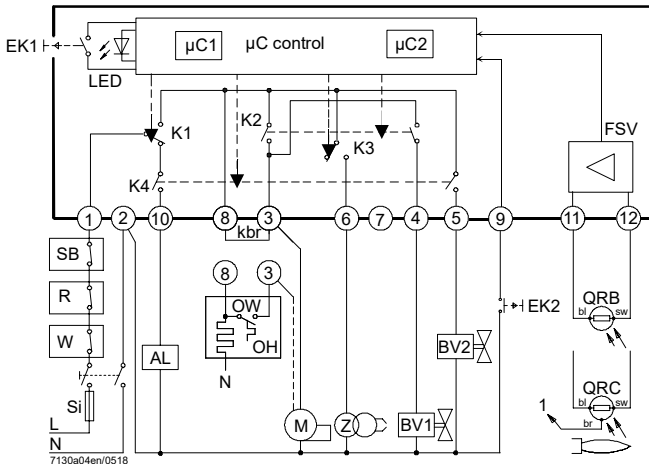

Control sequence LMO24

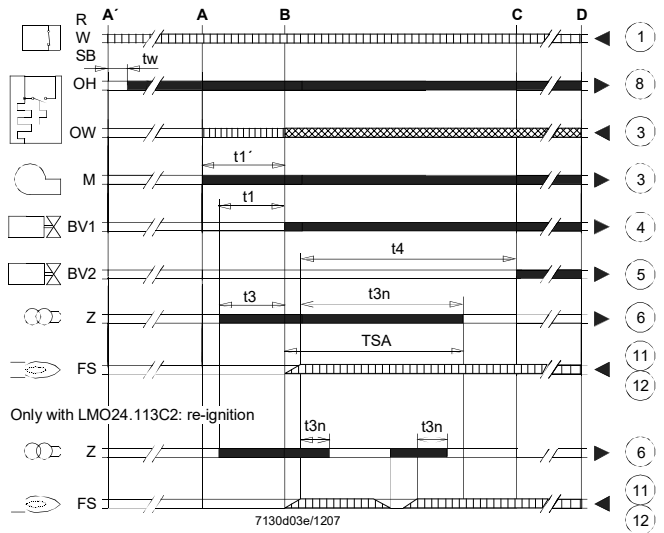

Connection diagram and internal diagram LMO44...

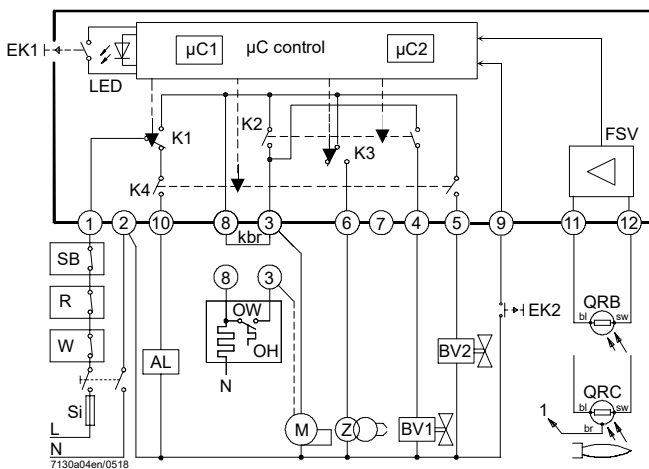

Control sequence LMO44...

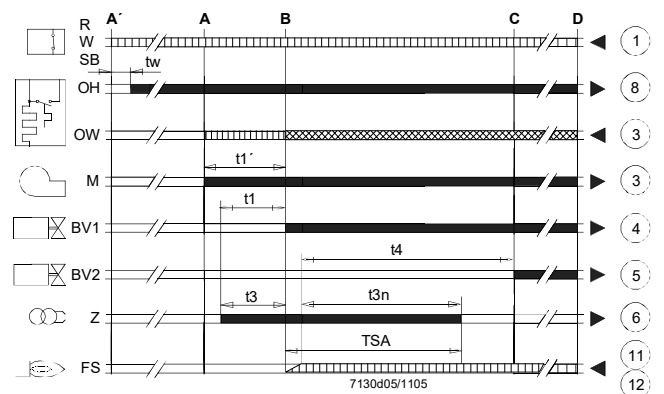



Caution!

Risk of damage to the switching contacts!

If the external primary fuse (Si) is blown due to overload or short-circuit at the terminals, the LMO must be replaced.

Legend

AL	Alarm device
BVx	Fuel valve
EK1	Lockout reset button
EK2	Remote lockout reset button
FS	Flame signal
FSV	Flame signal amplifier
Kx	Contacts of control relay
kbr	Cable link (required only when no oil preheater is used)
LED	3-color signal lamp
M	Burner motor
OW	Release contact of oil preheater
OH	Oil preheater
QRB1	Photo resistive flame detector
QRB3	Photo resistive flame detector
QRB4	Yellow flame detector
QRC1	Blue-flame detector
	bl = blue, br = brown, sw = black
R	Control thermostat or pressurestat
SB	Safety limit thermostat
Si	External primary fuse
W	Limit thermostat or pressure switch
Z	Ignition transformer
TSA	Ignition safety time
tw	Waiting time
t1	Prepurge time
t1'	Purge time
t3	Preignition time
t3n	Postignition time
t4	Interval from flame signal to release of fuel valve 2 (BV2)
A'	Start of startup sequence with burners using an oil preheater (OH)
A	Start of startup sequence with burners using no oil preheater (OH)
B	Time of flame establishment
C	Operating position
D	Controlled shutdown by control thermostat or pressurestat (R)
	Input/output signal 1 (ON)
	Input/output signal 0 (OFF)
	Input permissible signal 1 (ON) or 0 (OFF)
μC1	Microcontroller 1
μC2	Microcontroller 2

Dimensions

Dimensions in mm

LMO



Plug-in base AGK11

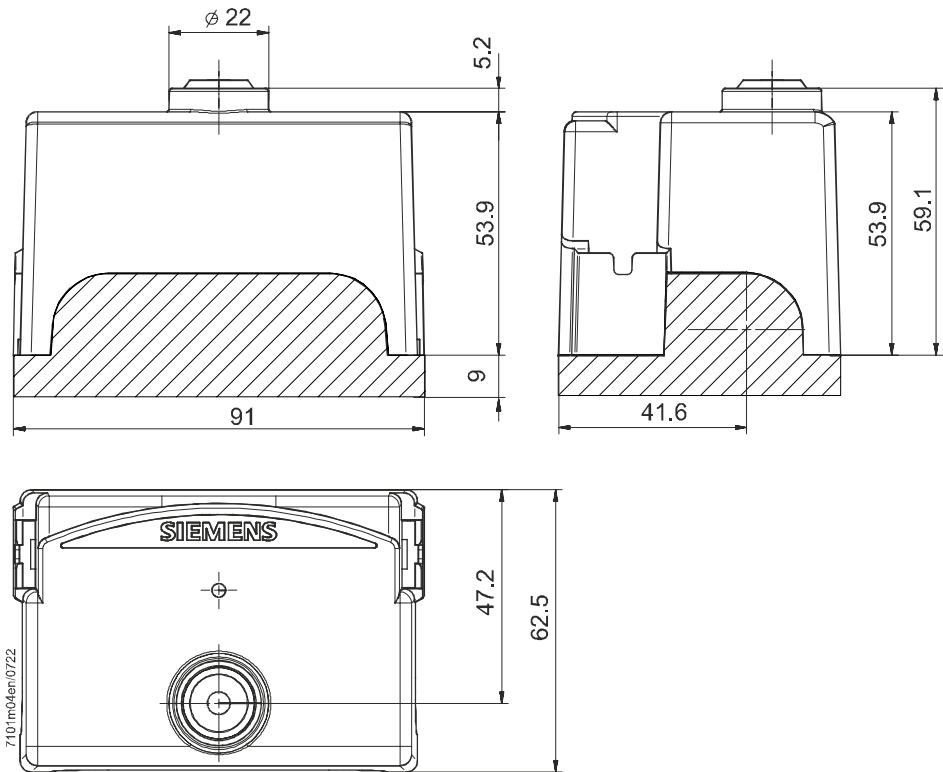

LMO with extension of
lockout reset button
AGK20

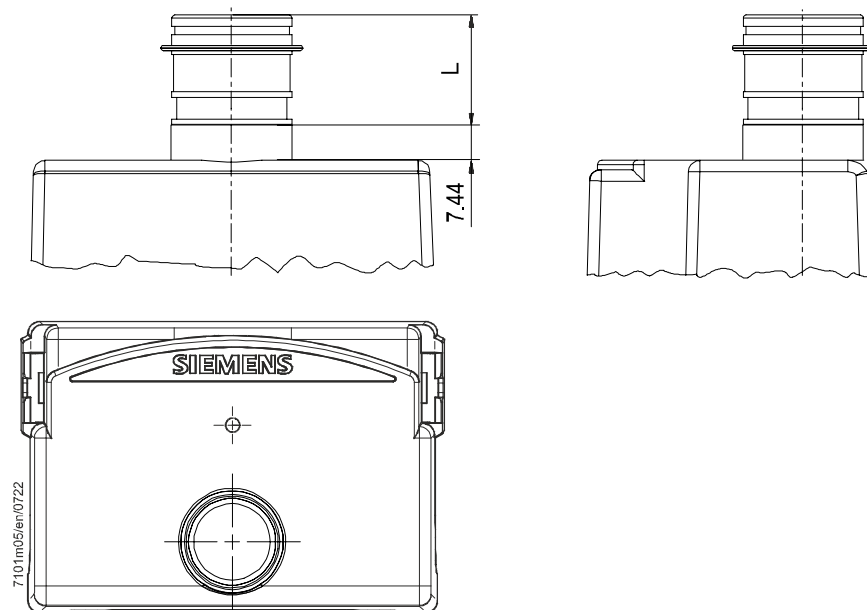

Type reference	Length «L» in mm
AGK20.19	19
AGK20.43	43
AGK20.55	55