



Electric Motors

Motor Manual

HOYER
MOTORS

Contents

1	Notice	3	9.4	Motor operation with a VFD	33
1.1	General information	3	9.5	Operating speed	33
1.2	Safety instructions	3	10	Maintenance	34
1.2.1	Operation	3	10.1	General	34
1.2.2	Lifting	3	10.2	Bearings and re-greasing	34
1.2.3	Transport	3	11	Disposal and environmental protection	37
2	Execution motors	4	11.1	Product disposal information	37
2.1	Maintenance and spare parts	4	11.2	RoHS and REACH	37
2.2	Special conditions of use	4	11.3	Electric motors	37
3	Receipt, transport and storage	5	11.4	Packaging material	37
3.1	Receipt and transport	5			
3.2	Storage	5			
4	Installation and commissioning	7			
4.1	General	7			
4.2	Support and alignment	7			
4.3	Measure the insulation resistance	7			
5	Electrical connection and cabling	9			
5.1	Direction of rotation	9			
5.2	Terminal box and terminal board	9			
5.3	Connection diagram	10			
6	Thermal protection	11			
6.1	Thermal protection with thermistors (PTC)	11			
6.2	Thermal protection with bimetal switches	11			
6.3	Temperature monitoring with Pt100 sensors	11			
6.4	Heater strip	11			
7	Motor data and parts	12			
7.1	Exploded view of motor and cross-section view ..	12			
7.2	Bearing types for motor sizes	13			
7.3	Permissible axial and radial bearing loads	17			
8	Frequency converter operation	30			
8.1	Operating speed	30			
8.2	Winding insulation	30			
8.3	Bearing deterioration in relation to VFD	30			
8.4	Additional solutions for limitation of bearing currents	31			
8.5	Hoyer VFD application suggestions	31			
9	Operation	32			
9.1	Considerations	32			
9.2	Checklist	32			
9.3	Cooling	32			

1 Notice

This manual must be followed to ensure proper and safe installation, operation and maintenance of the motor. Products must be handled by qualified personnel, and health and safety requirements and national legislation must be observed. Ignoring these instructions will invalidate all applicable warranties of Hoyer Motors.

1.1 General information

This manual concerns the following types of standard low voltage induction motors from Hoyer Motors: HMA4, HMC4, HMA3, HMC3, HMA2, HMC2, HMD, HMT, MS, Y2E1, Y2E2, YDT. Explosion-proof low voltage motors are not covered by this manual.

All motors are manufactured in accordance with IEC/EN 60034-1 and IEC/EN 60072 unless otherwise specified.

Motors are rated as standard for the ambient temperature range of -20°C to +40°C and site altitudes up to 1000 m above sea level. Low voltage motors are components for installation in machinery. The motors are CE marked according to the Low Voltage Directive 2014/35/EU.

Motors not fulfilling the IE3 efficiency level must, before the 1st of July 2021, be equipped with variable frequency drives (VFD) when used in the EU. Information about the required use of a VFD must be shown on the nameplate or an additional label or plate, and in the technical documentation of the motor.

1.2 Safety instructions

Personnel who commission, transport, maintain or install motors should have obtained qualified training and safety knowledge. Safety equipment is necessary to prevent accidents. Local regulations and requirements must also be observed. Failure in operation can cause injury to personnel and damage to the motor.

The specified data and recommendations must be observed to avoid hazardous situations and the risk of injury or damage.

Custom designs and other non-standard motors can vary in technical details. If in doubt contact Hoyer Motors, stating the type designation and serial number of the motor.

1.2.1 Operation

For safe operation it must be ensured that no external parts interfere with the rotating shaft.

The shaft key must be securely fastened in the keyway before the motor is started. If the motor is run for no-load testing, the key must be fixed in the keyway or removed.

The motor must be handled and operated properly to avoid accidents during operation. If the motor is not running properly, switch off the power supply. The power supply must be switched off when troubleshooting.

Maintenance is required and must be done on a regular basis to prevent failures.

1.2.2 Lifting

For safety reasons all Hoyer motors with frame size 100 or larger are equipped with eyebolts for lifting. Before lifting the motor, ensure that the eyebolts are undamaged and screwed tight. When lifting the motor, make sure that the motor is not attached to any equipment or mounted by the feet, shaft or flange. Only use the main eyebolts on the motor frame to lift the motor. Do not use damaged eyebolts. If crane slings are used, prevent them from slipping and maintain full control when lifting the motor.

1.2.3 Transport

The motor must be fixed on a pallet (by ropes, cables, bolts, etc.) during transport. This means it must be secured so it cannot move or be damaged during transport. Broken equipment and unstable machines can cause serious injuries.

2 Ex ec and tc motors

Below information is a special note for Ex ec and tc motors.

Designation of motors is according to EN/IEC standard: II 3D Ex tc IIIB T120°C Dc and II 3G Ex ec IIC T3 Gc. The motors must only be connected to certified Ex Relays. The hazardous 3-phase asynchronous motors are in accordance with EU directive 2014/34/EU and international standards EN/IEC 60079-0 Ed 7, EN/IEC 60079-7 Ed 5 and EN/IEC 60079-31 Ed 2. Only one electrical installation may be installed in one specified area(zone). For Ex ec parameter Time E must be taken into account.

All Hoyer Ex ex and tc motors are equipped with cable glands according to below table.

Cable glands for Ex ex and tc motors:

Size	Blind cap	
90	1xM20x1,5	1xM20x1,5
100	1xM20x1,5	1xM20x1,5
112	1xM20x1,5	1xM20x1,5
132	2xM25x1,5	1xM20x1,5
160	2xM40x1,5	2xM20x1,5
180	2xM40x1,5	2xM20x1,5
200	2xM50x1,5	2xM20x1,5
225	2xM50x1,5	2xM20x1,5
250	2xM63x1,5	2xM20x1,5
280	2xM63x1,5	2xM20x1,5
315	2xM63x1,5	2xM20x1,5
355	2xM72x2,0	2xM20x1,5

2.1 Maintenance and spare parts

The user is responsible for changing parts in accordance with life time of parts, in particular: bearings, grease and lubrication of shaft sealings. Installation, maintenance, repair and replacement of parts in this type of motors must only be carried out of qualified specialists according to EU directive 99/92, EN/IEC 60079-14, EN/IEC 60079-17 and EN/IEC 60079-19.

It is recommended that the IEC standard is followed according to the temperature and dust on the motor surface. Surface dust must not cause increase of motor temperature. Regularly cleaning is recommended. The radial shaft sealing ring is part of the EX certification. It is important

that the sealing rings are intact. The shaft sealing must be checked regularly, and if it is dry it must be lubricated. It is recommended that the motors are relubricated regularly. When replacing seal rings, use original ones. Replacing bearings also means replacing the seals. All machines must be inspected regularly for mechanical damage.

2.2 Special conditions of use

- The entries of the equipment shall be equipped with certified cable glands or blanking elements with compatible modes of protection for the intended use.
- All accessories associated to the motor to ensure smooth operation and safety shall provide a recognized protection type adapted to the specific use .
- When breather and drain devices will be used shall be certified for the intended used.
- User shall looked regularly after good bearing conditions, and shall not exceed the life time defined by manufacturer's instructions concerning plastic seals and O'rings shall be respected.
- When required in order to minimize the risk of hazards caused by electrostatic charges, clean the motor only with a wet rag or by nonfrictional means.
- The associated ratings for duties S2 to S9 are adjusted to ensure a winding temperature rise equal or below the temperature rise of specific duty S1.

3 Receipt, transport and storage

3.1 Receipt and transport

Upon receipt and for transport:

- Use transport locks for all transport operations.
- Avoid moisture and shocks during transport.
- Check the motor for external damage.
- If damage is found, inform the sales representative of Hoyer Motors.
- Check all nameplate data and compare it with the requirements for the motor.
- Remove transport locks if present.
- Turn the shaft by hand to check for free rotation.

3.2 Storage

- Ensure the use of correct lifting lugs. Lifting lugs are dimensioned for the weight of the motor.
- Do not apply extra weight.
- If necessary, use suitable special equipment such as lifting gear and ropes.
- Store in a dry, dust-free and vibration-free location.
- Carefully consider long-term storage procedures.

Short-term storage (less than 2 months)

The motor should be stored in a place with a controllable environment. A good warehouse or storage location has:

- Measure the insulation resistance and temperature of the windings to check whether the motor has been stored improperly, even for a short time.
- A stable temperature, preferably in the range from 10°C (50°F) to 50°C (120°F). If the anti-condensation heaters are energised and the surrounding air is above 50°C (120°F), ensure that the motor is not overheated.
- Low air humidity, preferably below 75%. The motor temperature must be kept above the dew point shown in the figure to prevent water vapour from condensing inside the motor. If the motor is equipped with anti-condensation heaters, they should be energised. Proper operation of the anti-condensation heaters must be checked periodically. If the motor is not equipped with anti-condensation heaters, other methods of heating the motor must be used to prevent water vapour from condensing in the motor.

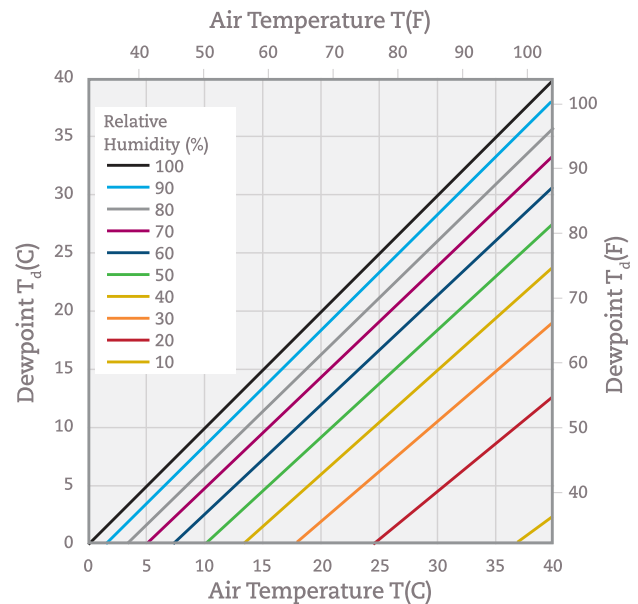

- A stable support free from excessive vibration and shocks. If vibration levels are expected to be too large, the motor should be isolated by placing suitable rubber blocks under the motor feet.
- Air that is ventilated, clean and free from dust and corrosive gases.
- Protection against harmful insects, vermin and chemicals.

Long-term storage (more than 2 months)

In addition to the measures described for short-term storage, the following actions are necessary:

- Measure the insulation resistance and temperature of the windings to check whether the motor has been stored improperly, even for a short time.
- Check the condition of the paintwork every three months. If corrosion is seen, remove it and apply a new coat of paint.
- Check the condition of the anti-corrosion coating on bare metal surfaces every three months. If corrosion is seen, remove it gently with emery cloth and apply an anti-corrosion coating.
- Provide small ventilation openings if the motor is stored in a wooden crate. Prevent water, dust and insects from entering the crate.

Motor Manual

Outdoor storage

If the motor must be stored outdoors, never leave the motor as is in the standard transport packaging. Instead the motor must be:

- Taken out of its plastic wrap.
- Covered to completely prevent rain from entering the motor. The cover should allow ventilation of the motor.
- Placed on at least 100 mm (4") high rigid supports, to ensure that no moisture can enter the motor from below.
- Protected against harmful insects and vermin.
- Packed in special outdoor packaging.

Drain plugs

The motor is equipped with drain plugs to let condensation water drain out. The drain plugs should be open when stored.

Horizontal mounting: For horizontally mounted motors, drain plugs are fitted at each end of the motor.

Vertical mounting: For vertically mounted motors, a minimum of two drain plugs are fitted on the lower end shield.

4 Installation and commissioning

4.1 General

To ensure correct protection and connection of the motor, check the nameplate data before installation and commissioning. Before working on the motor, disconnect and lock out the power supply. Before starting the motor, remove the transportation bracket and clean the shaft, feet and flange to remove the protective coating. It is recommended to grease the bearing during initial commissioning according to Table 18, Re-greasing interval and amount.

When performing installation and commissioning, make sure that the motor is earthed. When making insulation resistance measurements for commissioning, short the winding terminals before disconnecting the test leads to avoid the risk of electric shock. If the motor windings have been in contact with sea water, they must be inspected (contact Hoyer Motors).

Avoid resonances with a rotational frequency at twice the mains frequency due to assembly. Turn the rotor and listen for abnormal rubbing noises. Check the direction of rotation with the motor uncoupled. When mounting or removing couplings or other drive elements, cover them with a touch guard.

For a test run with the motor uncoupled, secure or remove the key(s) on the rotor shaft. Avoid excessive radial and axial bearing loads, except with roller bearings or angular contact bearings (see section 6.2).

Rotor balance:

- Half key as standard: Couplings must be half key balanced. If part of the shaft key is visible, be sure to perform mechanical balancing.
- Full key (non-standard): Couplings must be balanced without a key.

Ensure the required ventilation and clearance from other objects; see section 8.4. Do not obstruct ventilation openings, and ensure that exhaust air from other equipment is not drawn into the ventilation openings. Otherwise the motor may overheat.

4.2 Support and alignment

The end-user is fully responsible for construction of the support. The contact surface for the motor feet or flange must be free of paint, dirt and other objects. Otherwise the motor height may be incorrect or the motor may be misaligned.

Mount the motor on a sturdy, clean and flat support. It must be sufficiently rigid to withstand short circuit forces. It is important to ensure that the mounting conditions do not cause resonance at the rotational frequency or twice the supply frequency.

Always use suitable tools to mount or remove drive components. Do not hit the drive components with a hammer, as this can damage the bearings or degrade the balancing. The rotors are balancing with a half key for G2.5 according to ISO 21940-11. Make sure that the drive components are the same. Correct alignment is essential to avoid bearing failure, shaft failure and vibration failure. Use only suitable alignment methods. Re-check the alignment after final tightening of the bolts or studs. Check that drain holes and plugs face downwards and are fully functional and unobstructed. With a motor that is installed outdoors or that does not run continuously, open the drain hole so the motor housing is ventilated. This keeps the motor dry if a heater is not fitted in the motor or not energised.

Check these measurements before adjusting the alignment - not all variants are covered:

- Vertical positioning: To avoid motor tipping and bending, use shims to stabilise the motor.
- Horizontal positioning: Fix the motor axial position and make sure the axial gap is uniform.
- Stable support: Vibration free, accurate machine alignment and balanced drive.
- Foot/Foot-flange mounting: Mount the motor with the right bolts and tightening torques. Make sure the motor feet and/or flange bolts are in full contact with the mounting surface.

4.3 Measure the insulation resistance

Before commissioning, check the datasheet and measure the insulation resistance without any supply wires connected, as they can distort the measurement. If the meas-

ured insulation resistance is less than $10\text{ M}\Omega$ at 25°C , the winding must be oven dried. The nominal value is typically $100\text{ M}\Omega$. If the measured value is less than $2\text{ M}\Omega$, the insulation resistance is not acceptable. When oven drying the windings, set the oven temperature to approximately 85°C for 10 to 18 hours, followed by 100°C for 7 to 9 hours. The nominal insulation resistance drops by 50% for every 20°C rise in motor temperature. Measuring equipment must always be calibrated at least every year. Note that drain plugs or valves must be open during heating. After heating, make sure the plugs are fitted again.

5 Electrical connection and cabling

The motors are designed to operate with supply variations conforming to IEC 60034-1, Zone A: $\pm 5\%$ voltage and $\pm 2\%$ frequency. The motors will operate with greater variations according to Zone B of IEC 60034-1 section 7.3, but with larger variation in performance.

Three-phase motors manufactured by Hoyer Motors are designed according to IEC 60038 and IEC 60034-1 and can operate with the rated power and torque load within the mains voltage and frequency variations of zone A and, for a short time, of zone B.

Single-phase Hoyer motors can operate under these conditions with mains voltage and frequency variations of $\pm 5\%$ and $\pm 1\%$, respectively. If the voltage variation is greater, single-phase motors can only be operated with the torque load adjusted in proportion to the voltage dip.

Earthing must be carried out according to local regulations before the motor is connected to the supply voltage.

5.1 Direction of rotation

Motors are supplied as standard with clockwise rotation as seen from the drive end. The phase sequence is L1, L2, L3 as connected to the terminals shown in Figure 1. To change the direction of rotation, change the phase sequence by (for example) swapping L1 and L2. If the motor is unidirectional, make sure the shaft rotates in the same direction as the marked arrow.

5.2 Terminal box and terminal board

The terminal box contains the earthing terminal, terminal board and terminals for heating elements and temperature sensors (PTC and Pt100). Other auxiliary devices may also be located in the terminal box. Hoyer motors are equipped with three PTC sensors as standard. Heating elements are common in Hoyer marine motors with frame size 160 or larger.

Before working on the motor or attached machinery:

- Ensure that all supply voltages are switched off and protected against reactivation.
- Switch off auxiliary power circuits for accessories such as anti-condensation heaters.

- Check the supply voltage and frequency by comparing them with the rated data on the nameplate and the data sheet.
- Ensure that the terminal box is clean and dry.
- Close unused cable glands with blind caps.
- Check the terminal box cover gasket before refitting.

Always use suitable cable lugs for connection of all main supply cables and cables for auxiliary devices, and ensure that cables are corrected to the correct terminals.

Unless otherwise stated, motors are only intended for fixed installation. Cable glands/blind caps for entry points are metric. If cable glands or blind caps are replaced, the replacements must be at least the same IP class as the existing items.

Connection diagrams for the main supply and accessories such as PTC sensors or heaters are located inside the terminal box or cast in the terminal box cover.

All crimped connections should be made according to IEC 60352-2.

Tightening torques for terminal board studs:

Thread	M4	M5	M6	M8	M10	M12	M14	M16	M20
T (Nm)	1.8	2.5	3.5	7.0	12	18	35	55	80

Table 1 Terminal board tightening torques

Tightening torques for terminal box cover:

Thread	HMA - M4	HMC - M4	HMA - M5	HMC - M5	M6	M8	M10	M12
T (Nm)	1.1-1.3	2-4	1.1-1.3	2-4	6-8	15.5-17.5	31-35	56-60

Table 2 Terminal box cover tightening torques

To comply with EMC requirements and provide proper earthing, cables must be shielded and EMC cable glands are recommended. All incoming parts must have the same potential as the motor.

Cable glands and seals in cable entries must be suitable for the type and diameter of the cable concerned (clamping range). It is recommended that cables are mechanically protected and clamped close to the terminal box to fulfil the requirements of IEC 60079 and local requirements.

5.3 Connection diagram

As standard all three-phase motors are suitable for 400 V connection, unless otherwise stated.

- Motors with nameplate data D/Y 230/400V are connected as star (Y).
- Motors with nameplate data D/Y 400/690V are connected as delta (D).

The connection diagram is labelled inside the terminal box.

Generally, power to motors must be supplied and protected through protective devices such as RCDs, fuses, MCBs, MCCBs, etc. The connection diagram for Y/D is shown in Figure 1.

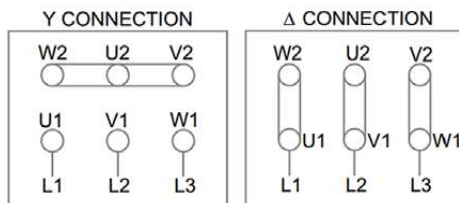

Figure 1 Connection types Y/D

Star-delta starting

Hoyer standard motors are suitable for star-delta starting. The starting current and torque in Y mode are approximately one-third of the starting current and torque in D mode. Make sure there is enough starting torque to accelerate the total load with star connection.

6 Thermal protection

Thermal protection is used to prevent motor overheating, and to monitoring purposes.

6.1 Thermal protection with thermistors (PTC)

All standard motors (IE1 and IE2 only from 160 and up) have PTC thermistors located in the stator windings.

It is recommended to connect the PTC thermistors to the variable speed drive or other protective equipment by appropriate means.

PTC thermistors are used to protect the motor from overheating. PTC thermistors are provided in sets of three, fitted in each phase, unless otherwise stated. The PTC resistance is 60 to 750 Ω at 20°C. The resistance rises in proportion to the temperature. At the peak temperature the resistance approaches infinity. This type of sensor is used in combination with a PLC or a relay for motor protection.

6.2 Thermal protection with bimetal switches

Thermal protection with bimetal switches is not standard and can be added in the motors upon request. Bimetal switches are used to protect the motor from overheating. Bimetal switches are normally fitted in sets of three, wired in series. Each switch is placed on a phase winding and opens or closes at a specific winding temperature. The bimetal switches are intended to be connected to an external protective relay that switches off power if the motor overheats.

6.3 Temperature monitoring with Pt100 sensors

Pt100 sensors are not standard and can be added upon request. Pt100 sensors can be fitted in the motor both in the windings and in the bearings. Pt100 sensors can track the temperature rise where they are fitted. This is often used for monitoring motor temperatures, for example in windings or bearings, and it can indicate overheating. The signals can be processed and used in PLCs.

6.4 Heater strip

A heater strip can be fitted in a motor. A heater strip allows a minimum temperature to be maintained inside the motor. This prevent moisture condensation during cool-down of the motor. Heater strips are available with two different

rated voltages (220–240 V and 110–120 V). The heater strip can be energised when the motor is not running. Heater strips are standard for marine motors with frame size 160 or larger.

7 Motor data and parts

7.1 Exploded view of motor and cross-section view

Figure 2 below shows an exploded view of a cast iron motor.
Figure 3 shows a cross-section view of an aluminium motor.

Note that the bearing retainer plate is secured on the inside at the drive end.

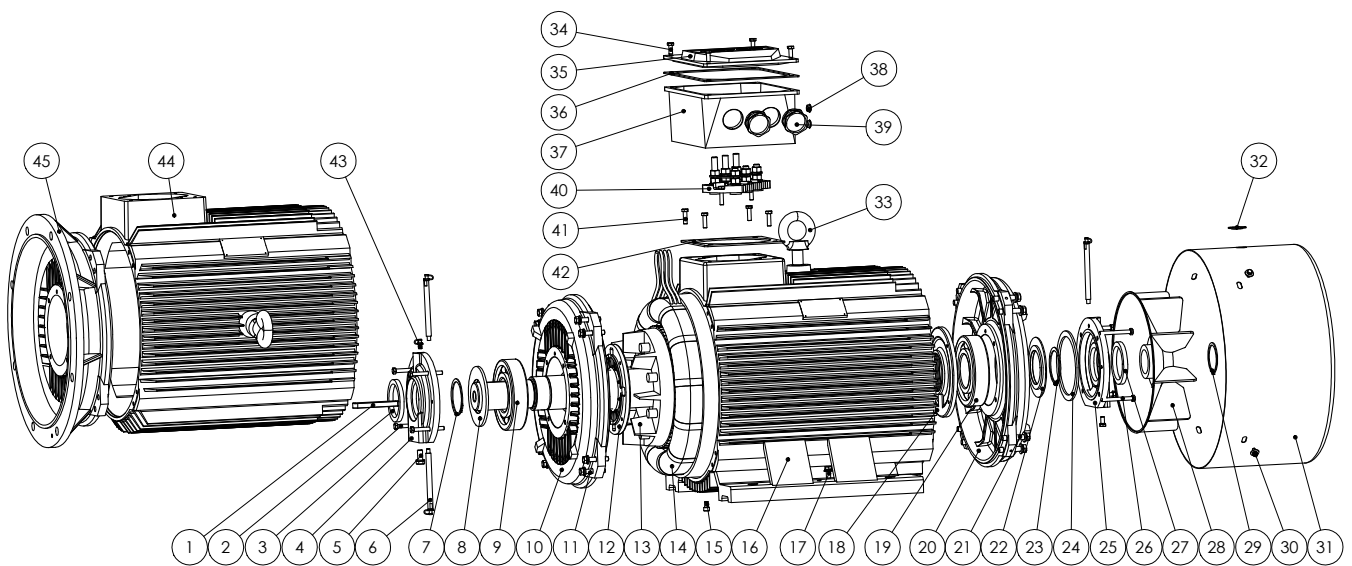

Item No.	Part name	Item No.	Part name
1	Key	24	Spring wave washer
2	Sealing ring_De	25	Outer bearing cap_NDE
3	Bolt	26	Bolt
4	Outer bearing cap_DE	27	Sealing ring_NDE
5	Bolt & O-ring	28	Cooling fan
6	Grease pipe	29	Circlip
7	Circlip	30	Bolt & Washer
8	Oil slinger	31	Fan cover
9	Bearing_DE	32	Rubber plug
10	B3 and shield_DE	33	Eye bolt
11	Bolt & Washer	34	Bolt
12	Inner bearing cap_DE	35	Terminal box cover
13	Rotor with shaft	36	Gasket
14	Winding stator	37	Terminal box base
15	Bolt & O-ring	38	Blind cap
16	B3 housing	39	Cable gland
17	Bolt & Washer	40	Terminal board
18	Inner bearing cap_NDE	41	Bolt
19	Bearing_NDE	42	Gasket
20	B3 end shield_NDE	43	Grease nipple
21	Bolt & Washer	44	B5 housing
22	Oil slinger	45	B5 flange
23	Circlip		

Figure 2 Exploded view of a cast iron motor

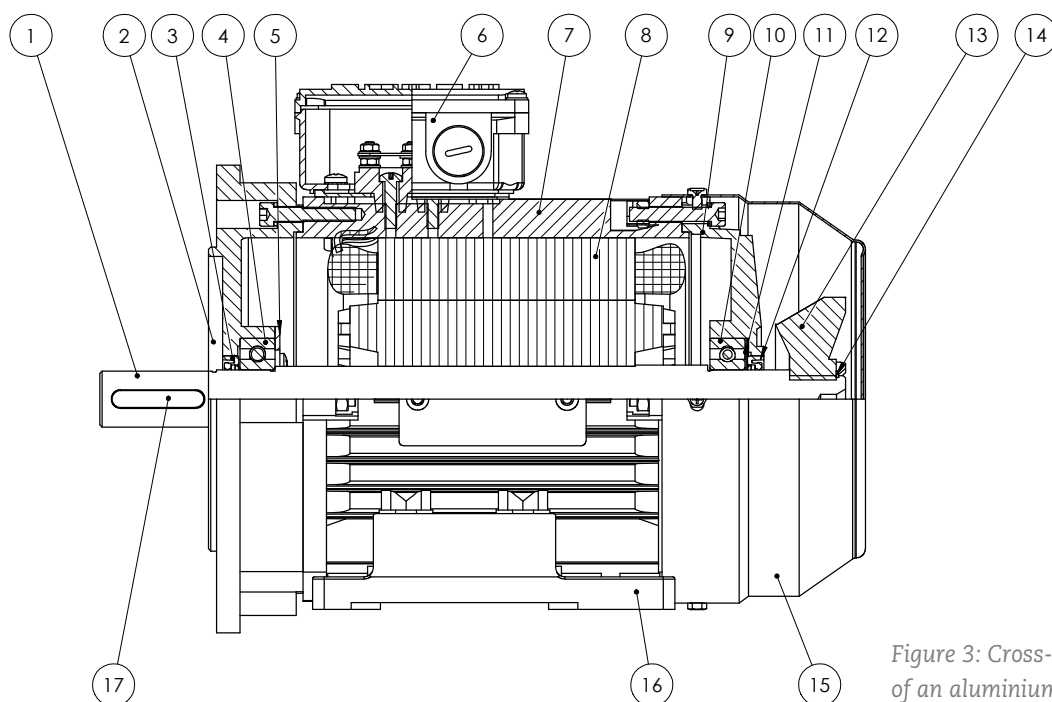

Figure 3: Cross-section view of an aluminium motor

Parts list					
1	Rotor and shaft	7	Motor housing	13	Cooling fan
2	DE flange	8	Stator winding	14	Retaining ring
3	DE oil seal	9	NDE shield	15	Fan cover
4	DE bearing	10	NDE bearing	16	Feet
5	Bearing retainer plate (secured)	11	Preload washer	17	Key
6	Terminal box	12	NDE oil seal		

7.2 Bearing types for motor sizes

The general bearing types and sizes for the various motor types and sizes for the various motor sizes and IE classes are shown in Table 3, Table 4, Table 5 and Table 6 for classes IE1 to IE4, respectively. Type 2Z and 2RS bearings or equivalent closed bearings are greased for life. Always ensure that the shaft seals are intact. Note that differences are possible between the bearing size and the actual frame size.

Motors with re-greaseable bearings must be greased according to Section 10.2 and the greasing data plate on the motor. In case of doubt, contact Hoyer Motors.

Frame size	Drive end (DE)		Non-drive end (NDE)	
	2-pole	4/6/8-pole	2-pole	4/6/8-pole
63	6201-2RS/C3		6201-2RS/C3	
71	6203-2RS/C3		6202-2RS/C3	
80	6205-2RS/C3		6204-2RS/C3	
90	6206-2RS/C3		6205-2RS/C3	
100	6206-2RS/C3		6206-2RS/C3	
112	6306-2RS/C3		6306-2RS/C3	
132	6308-2RS/C3		6308-2RS/C3	
160	6309-2RS/C3		6309-2RS/C3	
180	6311/C3		6311/C3	
200	6312/C3		6312/C3	
225	6312/C3	6313/C3	6312/C3	
225M1	6313/C3		6313/C3	
225M1 High Output	6313/C3	6314/C3	6313/C3	
250	6313/C3	6314/C3	6313/C3	
250M1 High Output	6314/C3	6315/C3	6314/C3	
280	6314/C3	6317/C3	6314/C3	
280M1 High Output 280MB High Output	6315/C3	6317/C3	6315/C3	6317/C3
315	6317/C3	NU319 (B3) 6319/C3 (B5/B35)	6317/C3	6319/C3
355	6319/C3	NU322 (B3) 6322/C3 (B5/B35)	6319/C3	6322/C3
400	6319/C3	6326/C3 (≤560 kW)	6319/C3	6326/C3

Table 3 Standard bearing sizes in IE1 Hoyer motors

Frame size	Drive end (DE)		Non-drive end (NDE)	
	2-pole	4/6/8/10/12-pole	2-pole	4/6/8/10/12-pole
56	6201-2Z/C3		6201-2Z/C3	
63	6201-2Z/C3		6201-2Z/C3	
71	6202-2Z/C3		6202-2Z/C3	
80	6204-2Z/C3		6204-2Z/C3	
90	6205-2Z/C3		6205-2Z/C3	
100	6206-2Z/C3		6206-2Z/C3	
112	6306-2Z/C3		6306-2Z/C3	
132	6308-2Z/C3		6308-2Z/C3	
160	6309-2Z/C3		6309-2Z/C3	
180	6311/C3		6311/C3	
200	6312/C3		6312/C3	
225	6312/C3	6313/C3	6312/C3	
225 High Output	6313/C3	6314/C3	6313/C3	
250	6313/C3	6314/C3	6313/C3	
250 High Output	6314/C3	6315/C3	6314/C3	
280	6314/C3	6317/C3	6314/C3	
280 High Output	6317/C3		6317/C3	
315	6317/C3	6319/C3	6317/C3	
315 High Output	6319/C3		6319/C3	
355	6319/C3	6322/C3	6319/C3	
400	6319/C3	6326/C3	6319/C3	6326/C3

Table 4 Standard bearing sizes in IE2 Hoyer motors

Frame size	Drive end (DE)		Non-drive end (NDE)	
	2-pole	4/6-pole	2-pole	4/6-pole
80	6204-ZZ/C3		6204-2Z/C3	
90	6205-2Z/C3		6205-2Z/C3	
100	6206-2Z/C3		6206-2Z/C3	
112	6306-2Z/C3		6306-2Z/C3	
132	6308-2Z/C3		6308-2Z/C3	
160	6309-2Z/C3		6309-2Z/C3	
180	6311-2Z/C3		6311-2Z/C3	
200	6312/C3		6312/C3	
225	6312/C3	6313/C3	6312/C3	
250	6313/C3	6314/C3	6313/C3	
280	6314/C3	6317/C3	6314/C3	
315	6317/C3	6319/C3 NU319	6317/C3	6319/C3
355	6319/C3	6322/C3 NU322	6319/C3	6322/C3

Table 5 Standard bearing sizes in IE3 Hoyer motors

Frame size	Drive end (DE)		Non-drive end (NDE)	
	2-pole	4/6-pole	2-pole	4/6-pole
80	6204-ZZ/C3		6203-ZZ/C3	
90	6205-ZZ/C3		6204-ZZ/C3	
100	6306-ZZ/C3		6205-ZZ/C3	
112	6306-ZZ/C3		6205-ZZ/C3	
132	6208-ZZ/C3		6206-ZZ/C3	
160	6209-ZZ/C3		6209-ZZ/C3	
180	6211/C3	6311/C3	6211/C3	
200	6212/C3	6312/C3	6212/C3	
225	6312/C3	6313/C3	6312/C3	
250	6313/C3	6314/C3	6313/C3	
280	6314/C3	6317/C3	6314/C3	
315	6317/C3	6319/C3 NU319	6317/C3	6319/C3
355	6319/C3	6322/C3 NU322	6319/C3	6322/C3

Table 6 Standard bearing sizes in IE4 Hoyer motors

7.3 Permissible axial and radial bearing loads

This section provides information on radial and axial loads for standard Hoyer IE3 motors. Values can vary. If specific calculations are needed for other IE classes or environmental requirements, please contact Hoyer Motors. Specific permissible axial and radial loads on bearings can be provided upon request by contacting Hoyer Motors.

The main conditions for axial and radial loads are listed below. Permissible loads will vary under deviating conditions.

- 25°C ambient temperature (80°C bearing temperature)
- WT grease for closed bearings
- Pure axial or radial loads
- Normal bearing cleanliness (only for shielded bearing calculations (see L10h and grease lifetime, especially for vertical mounting))
- Vibration levels below limits stated in IEC 60034-14
- No or insignificant bearing current
- Wave spring forces are worst case (maximum possible value)

Note the following:

Motors equipped with cylindrical roller bearings must only be operated with a radial load on the motor shaft. Ensure compliance with the minimum load and preload. Other types of mounting may damage the bearings.

Motors equipped with angular contact bearings must only be operated with a axial load on the motor shaft in the correct direction. The load must not change direction, as otherwise the bearings may be damaged. Ensure compliance with the minimum load and preload.

Permissible radial loads for deep groove ball bearings

X0	Permissible radial load at the start of the shaft extension
Xavg	Permissible radial load at the middle of the shaft extension
Xmax	Permissible radial load at the end of the shaft extension

Table 7 Load definitions

Permissible radial loads for deep groove ball bearings

Frame size	Bearing size	Motor info	Speed	Frequency	Poles	20.000 running hours			40.000 running hours		
			[RPM]	[Hz]		X0 [N]	Xavg [N]	Xmax [N]	X0 [N]	Xavg [N]	Xmax [N]
80	6204-2Z/C3	HMA3 80 2-4	1500	50	4	990	884	799	786	702	634
		HMA3 80 2-2	3000	50	2	786	702	634	624	557	503
		HMA3 80 1-2	3000	50	2	786	702	634	624	557	503
90	6205-2Z/C3	HMA3 90L-6	1000	50	6	1284	1155	1049	1019	916	833
		HMA3 90S-6	1000	50	6	1263	1114	997	1002	884	791
		HMA3 90L-4	1500	50	4	1121	1009	916	890	801	727
		HMA3 90S-4	1500	50	4	1103	973	871	876	773	691
		HMA3 90L-2	3000	50	2	890	801	727	706	635	577
		HMA3 90S-2	3000	50	2	876	773	691	695	613	549
		HMA3 100L-6	1000	50	6	1730	1532	1375	1373	1216	1091
100	6206-2Z/C3	HMA3 100L2-4	1500	50	4	1511	1338	1201	1199	1062	953
		HMA3 100L1-4	1500	50	4	1511	1338	1201	1199	1062	953
		HMA3 100L-2	3000	50	2	1199	1062	953	952	843	757
		HMA3 112M-6	1000	50	6	2503	2249	2042	1986	1785	1621
112	6306-2Z/C3	HMA3 112M-4	1500	50	4	2186	1965	1784	1735	1559	1416
		HMA3 112M-2	3000	50	2	1735	1559	1416	1377	1238	1124
		HMA3 132M2-6	1000	50	6	3581	3146	2805	2842	2497	2226
132	6308-2Z/C3	HMA3 132M1-6	1000	50	6	3581	3146	2805	2842	2497	2226
		HMA3 132S-6	1000	50	6	3521	3037	2670	2794	2410	2119
		HMA3 132M-4	1500	50	4	3128	2748	2450	2483	2181	1945
		HMA3 132S-4	1500	50	4	3076	2653	2332	2441	2106	1851
		HMA3 132S2-2	3000	50	2	2441	2106	1851	1938	1671	1469
		HMA3 132S1-2	3000	50	2	2441	2106	1851	1938	1671	1469
		HMC3 160L-6	1000	50	6	4586	4010	3563	3640	3183	2828
160	6309-2Z/C3	HMC3 160M-6	1000	50	6	4505	3877	3402	3576	3077	2700
		HMC3 160L-4	1500	50	4	4006	3503	3112	3180	2780	2470
		HMC3 160M-4	1500	50	4	3936	3386	2972	3124	2688	2359
		HMC3 160L-2	3000	50	2	3180	2780	2470	2524	2207	1961
		HMC3 160M1-2	3000	50	2	3124	2688	2359	2479	2133	1872
		HMC3 160M1-2	3000	50	2	3124	2688	2359	2479	2133	1872
		HMC3 160L-6	1000	50	6	4586	4010	3563	3640	3183	2828
	6309/C3	HMC3 160M-6	1000	50	6	4505	3877	3402	3576	3077	2700
		HMC3 160L-4	1500	50	4	4006	3503	3112	3180	2780	2470
		HMC3 160M-4	1500	50	4	3936	3386	2972	3124	2688	2359
		HMC3 160L-2	3000	50	2	3180	2780	2470	2524	2207	1961
		HMC3 160M1-2	3000	50	2	3124	2688	2359	2479	2133	1872
		HMC3 160M1-2	3000	50	2	3124	2688	2359	2479	2133	1872
		HMC3 160M1-2	3000	50	2	3124	2688	2359	2479	2133	1872

Frame size	Bearing size	Motor info	Speed	Frequency	Poles	20.000 running hours			40.000 running hours		
			[RPM]	[Hz]		X0 [N]	Xavg [N]	Xmax [N]	X0 [N]	Xavg [N]	Xmax [N]
180	6311-2Z/C3	HMC3 180L-6	1000	50	6	6287	5562	4987	4990	4415	3958
		HMC3 180L-4	1500	50	4	5492	4859	4357	4359	3857	3458
		HMC3 180M-4	1500	50	4	5433	4753	4223	4312	3772	3352
		HMC3 180M-2	3000	50	2	4312	3772	3352	3423	2994	2661
	6311/C3	HMC3 180L-6	1000	50	6	6287	5562	4987	4990	4415	3958
		HMC3 180L-4	1500	50	4	5492	4859	4357	4359	3857	3458
		HMC3 180M-4	1500	50	4	5433	4753	4223	4312	3772	3352
		HMC3 180M-2	3000	50	2	4312	3772	3352	3423	2994	2661
200	6312-2Z/C3	HMC3 200L2-6	1000	50	6	7126	6363	5747	5656	5050	4561
		HMC3 200L1-6	1000	50	6	7126	6363	5747	5656	5050	4561
		HMC3 200L-4	1500	50	4	6225	5558	5020	4941	4412	3985
		HMC3 200L2-2	3000	50	2	4941	4412	3985	3921	3501	3163
		HMC3 200L1-2	3000	50	2	4941	4412	3985	3921	3501	3163
	6312/C3	HMC3 200L2-6	1000	50	6	7126	6363	5747	5656	5050	4561
		HMC3 200L1-6	1000	50	6	7126	6363	5747	5656	5050	4561
		HMC3 200L-4	1500	50	4	6225	5558	5020	4941	4412	3985
		HMC3 200L2-2	3000	50	2	4941	4412	3985	3921	3501	3163
		HMC3 200L1-2	3000	50	2	4941	4412	3985	3921	3501	3163
		HMC3 225M-6	1000	50	6	7043	6148	5455	5590	4880	4329
		HMC3 225M-4	1500	50	4	6152	5371	4765	4883	4263	3782
225	6312/C3	HMC3 225S-4	1500	50	4	6105	5293	4671	4846	4201	3708
		HMC3 225M-2	3000	50	2	4883	4382	3974	3876	3478	3154
		HMC3 225M-6	1000	50	6	8071	7040	6243	6406	5588	4955
		HMC3 225M-4	1500	50	4	7051	6150	5454	5596	4882	4329
	6313-2Z/C3	HMC3 225S-4	1500	50	4	6998	6061	5346	5554	4811	4243
		HMC3 225M-2	3000	50	2	5596	5019	4549	4442	3984	3611
		HMC3 225M-6	1000	50	6	8071	7040	6243	6406	5588	4955
		HMC3 225M-4	1500	50	4	7051	6150	5454	5596	4882	4329
	6313/C3	HMC3 225S-4	1500	50	4	6998	6061	5346	5554	4811	4243
		HMC3 225M-2	3000	50	2	5596	5019	4549	4442	3984	3611
		HMC3 225M-6	1000	50	6	8071	7040	6243	6406	5588	4955
		HMC3 225M-4	1500	50	4	7051	6150	5454	5596	4882	4329

L10 Grease life 37100 h

L10 Grease life 32700 h

L10 Grease life 28800 h

Motor Manual

Frame size	Bearing size	Motor info	Speed	Frequency	Poles	20.000 running hours			40.000 running hours		
			[RPM]	[Hz]		X0 [N]	Xavg [N]	Xmax [N]	X0 [N]	Xavg [N]	Xmax [N]
250	6313-2Z/C3	HMC3 250M-6	1000	50	6	8138	7210	6472	6459	5723	5137
		HMC3 250M-4	1500	50	4	7109	6299	5654	5642	4999	4488
		HMC3 250M-2	3000	50	2	5642	4999	4488	4478	3968	3562
	6313/C3	HMC3 250M-6	1000	50	6	8138	7210	6472	6459	5723	5137
		HMC3 250M-4	1500	50	4	7109	6299	5654	5642	4999	4488
		HMC3 250M-2	3000	50	2	5642	4999	4488	4478	3968	3562
	6314/C3	HMC3 250M-6	1000	50	6	9277	8215	7370	7363	6520	5850
		HMC3 250M-4	1500	50	4	8105	7176	6438	6433	5696	5110
		HMC3 250M-2	3000	50	2	6433	5696	5110	5106	4521	4056
280	6314/C3	HMC3 280M-6	1000	50	6	9284	8367	7614	7369	6641	6044
		HMC3 280S-6	1000	50	6	9183	8205	7416	7289	6513	5886
		HMC3 280M-4	1500	50	4	8110	7309	6652	6437	5801	5280
		HMC3 280S-4	1500	50	4	8022	7168	6478	6367	5689	5142
		HMC3 280M-2	3000	50	2	6437	5801	5280	5109	4604	4190
		HMC3 280S-2	3000	50	2	6367	5689	5142	5054	4516	4081
	6317/C3	HMC3 280M-6	1000	50	6	11751	10575	9613	9327	8394	7630
		HMC3 280S-6	1000	50	6	11626	10371	9361	9227	8231	7430
		HMC3 280M-4	1500	50	4	10266	9238	8398	8148	7333	6666
		HMC3 280S-4	1500	50	4	10156	9060	8177	8061	7191	6490
		HMC3 280M-2	3000	50	2	8148	7333	6666	6467	5820	5290
		HMC3 280S-2	3000	50	2	8061	7191	6490	6398	5707	5151

Motor Manual

Frame size	Bearing size	Motor info	Speed	Frequency	Poles	20.000 running hours			40.000 running hours		
			[RPM]	[Hz]		X0 [N]	Xavg [N]	Xmax [N]	X0 [N]	Xavg [N]	Xmax [N]
315	6317/C3	HMC3 315L2-6	1000	50	6	11936	10828	9907	9474	8594	7863
		HMC3 315L1-6	1000	50	6	11936	10828	9907	9474	8594	7863
		HMC3 315M-6	1000	50	6	11936	10828	9907	9474	8594	7863
		HMC3 315S-6	1000	50	6	11747	10507	9503	9324	8339	7543
		HMC3 315L2-4	1500	50	4	10427	9459	8655	8276	7507	6869
		HMC3 315L1-4	1500	50	4	10427	9459	8655	8276	7507	6869
		HMC3 315M-4	1500	50	4	10427	9459	8655	8276	7507	6869
		HMC3 315S-4	1500	50	4	10262	9179	8302	8145	7285	6589
		HMC3 315L2-2	3000	50	2	8271	7628	7078	6565	6055	5618
		HMC3 315L1-2	3000	50	2	8271	7628	7078	6565	6055	5618
		HMC3 315M-2	3000	50	2	8271	7628	7078	6565	6055	5618
		HMC3 315S-2	3000	50	2	8139	7419	6815	6460	5888	5409
	6319/C3	HMC3 315L2-6	1000	50	6	13582	12312	11259	10780	9772	8937
		HMC3 315L1-6	1000	50	6	13582	12312	11259	10780	9772	8937
		HMC3 315M-6	1000	50	6	13582	12312	11259	10780	9772	8937
		HMC3 315S-6	1000	50	6	13370	11948	10799	10612	9483	8571
		HMC3 315L2-4	1500	50	4	11865	10756	9836	9418	8537	7807
		HMC3 315L1-4	1500	50	4	11865	10756	9836	9418	8537	7807
		HMC3 315M-4	1500	50	4	11865	10756	9836	9418	8537	7807
		HMC3 315S-4	1500	50	4	11680	10437	9434	9270	8284	7487
		HMC3 315L2-2	3000	50	2	9412	8675	8046	7470	6886	6386
		HMC3 315L1-2	3000	50	2	9412	8675	8046	7470	6886	6386
		HMC3 315M-2	3000	50	2	9412	8675	8046	7470	6886	6386
		HMC3 315S-2	3000	50	2	9264	8437	7746	7353	6696	6148
	NU319/C3										

Motor Manual

Frame size	Bearing size	Motor info	Speed	Frequency	Poles	20.000 running hours			40.000 running hours		
			[RPM]	[Hz]		X0 [N]	Xavg [N]	Xmax [N]	X0 [N]	Xavg [N]	Xmax [N]
355	6319/C3	HMC3 355L-6	1000	50	6	13728	12670	11763	10896	10056	9337
		HMC3 355M2-6	1000	50	6	13728	12670	11763	10896	10056	9337
		HMC3 355M1-6	1000	50	6	13728	12670	11763	10896	10056	9337
		HMC3 355L1-4	1500	50	4	11992	11068	10276	9518	8785	8156
		HMC3 355M-4	1500	50	4	11992	11068	10276	9518	8785	8156
		HMC3 355L1-2	3000	50	2	9514	8902	8364	7551	7065	6639
		HMC3 355M-2	3000	50	2	9514	8902	8364	7551	7065	6639
	6322/C3	HMC3 355L-6	1000	50	6	17562	16200	15033	13939	12858	11932
		HMC3 355M2-6	1000	50	6	17562	16200	15033	13939	12858	11932
		HMC3 355M1-6	1000	50	6	17562	16200	15033	13939	12858	11932
		HMC3 355L1-4	1500	50	4	15342	14152	13133	12177	11232	10423
		HMC3 355M-4	1500	50	4	15342	14152	13133	12177	11232	10423
		HMC3 355L1-2	3000	50	2	-	-	-	-	-	-
		HMC3 355M-2	3000	50	2	-	-	-	-	-	-
NU322/C3	-										
400	Please contact Hoyer										

Table 8

Permissible axial loads for open deep groove ball bearings, horizontal

Frame size	Bearing size	20.000 running hours							
		50 Hz		50 Hz		50 Hz		50 Hz	
		2-pole 3000[RPM]		4-pole 1500[RPM]		6-pole 1000[RPM]		8-pole 750[RPM]	
		F (push)	F (Pull)	F (push)	F (Pull)	F (push)	F (Pull)	F (push)	F (Pull)
		(N)	(N)	(N)	(N)	(N)	(N)	(N)	(N)

Horizontal mounting

80	6204-2Z/C3	930	250	1136	456	1290	610	1416	736
90	6205-2Z/C3	995	295	1221	521	1388	688	1527	827
100	6206-2Z/C3	1272	472	1578	778	1805	1005	1992	1192
112	6306-2Z/C3	1721	781	2160	1220	2485	1545	2753	1813
132	6308-2Z/C3	2342	1182	2960	1800	3418	2258	3796	2636
160	6309-2Z/C3	2921	1681	3728	2488	4326	3086	4819	3579
	6309/C3	2921	1681	3728	2488	4326	3086	4819	3579
180	6311-2Z/C3	3684	2364	4745	3425	5531	4211	6179	4859
	6311/C3	3684	2364	4745	3425	5531	4211	6179	4859
200	6312-2Z/C3	4141	2801	5360	4020	6262	4922	7006	5666
	6312/C3	4141	2801	5360	4020	6262	4922	7006	5666
225	6312/C3	4141	2801	-	-	-	-	-	-
	6313-2Z/C3	-	-	6024	4684	7054	5714	7903	6563
	6313/C3	-	-	6024	4684	7054	5714	7903	6563
250	6313-2Z/C3	4633	3293	-	-	-	-	-	-
	6313/C3	4633	3293	-	-	-	-	-	-
	6314/C3	-	-	6803	5403	7978	6578	8945	7545
280	6314/C3	5218	3818	-	-	-	-	-	-
	6317/C3	-	-	8278	6578	9708	8008	10886	9186
315	6317/C3	6348	4648	-	-	-	-	-	-
	6319/C3	-	-	9360	7140	10948	8728	12256	10036
	NU319/C3	Special							
355	6319/C3	7217	4997	-	-	-	-	-	-
	6322/C3	-	-	11452	8512	13373	10433	14956	12016
	NU322/C3	-							
400	Please contact Hoyer								

Table 9

Frame size	Bearing size	40.000 runing hours							
		50 Hz		50 Hz		50 Hz		50 Hz	
		2-pole 3000[RPM]		4-pole 1500[RPM]		6-pole 1000[RPM]		8-pole 750[RPM]	
		F (push)	F (Pull)	F (push)	F (Pull)	F (push)	F (Pull)	F (push)	F (Pull)
		(N)	(N)	(N)	(N)	(N)	(N)	(N)	(N)

Horizontal mounting

80	6204-2Z/C3	776	96	930	250	1043	363	1136	456
90	6205-2Z/C3	827	127	995	295	1119	419	1221	521
100	6206-2Z/C3	1045	245	1272	472	1440	640	1578	778
112	6306-2Z/C3	1396	456	1251	781	1962	1022	2160	1220
132	6308-2Z/C3	1884	724	2342	1182	2681	1800	2283	1123
160	6309-2Z/C3	2323	1083	2921	1681	3363	2123	3728	2488
	6309/C3	2323	1083	2921	1681	3363	2488	2858	1618
180	6311-2Z/C3	2898	1578	3684	2364	4266	3425	3230	1910
	6311/C3	2898	1578	3684	2364	4266	3425	3230	1910
200	6312-2Z/C3	3240	1900	4141	2801	4809	4020	3603	2263
	6312/C3	3240	1900	4141	2801	4809	4020	3603	2263
225	6312/C3	3240	1900	-	-	-	-	-	-
	6313-2Z/C3	-	-	4633	3293	5395	4684	2373	1033
	6313/C3	-	-	4633	3293	5395	4684	4014	2674
250	6313-2Z/C3	3603	2263	-	-	-	-	-	-
	6313/C3	3603	2263	-	-	-	-	-	-
	6314/C3	-	-	5218	3818	6087	5403	4233	2833
280	6314/C3	4044	2644	-	-	-	-	-	-
	6317/C3	-	-	6348	4648	7406	6578	5370	3670
315	6317/C3	4920	3220	-	-	-	-	-	-
	6319/C3	-	-	6957	5257	8132	6432	9100	7400
	NU319/C3	Special							
355	6319/C3	5630	3410	-	-	-	-	-	-
	6322/C3	-	-	8859	5919	10280	8512	-	-
	NU322/C3	Special							
400		Please contact Hoyer							

Table 10

L10 Grease life 37100 h

L10 Grease life 32700 h

L10 Grease life 28800 h

Permissible axial loads for open deep groove ball bearings, vertical

Frame size	Motor info	Bearing size	20.000 running hours		40.000 running hours	
			50 Hz		50 Hz	
			F (push)	F (Pull)	F (push)	F (Pull)
			(N)	(N)	(N)	(N)

Vertical mounting

80	HMA3 80 1-2	6204-2Z/C3	951	228	798	75
	HMA3 80 2-2		956	223	802	70
	HMA3 80 2-4		1174	418	968	212
90	HMA3 90S-2	6205-2Z/C3	1032	257	865	90
	HMA3 90L-2		1040	249	872	82
	HMA3 90S-4		1269	473	1043	247
	HMA3 90L-4		1281	460	1055	234
	HMA3 90S-6		1436	641	1167	371
	HMA3 90L-6		1458	619	1189	349
100	HMA3 100L-2	6206-2Z/C3	1330	414	1103	188
	HMA3 100L1-4		1659	697	1353	391
	HMA3 100L2-4		1674	682	1368	376
	HMA3 100L-6		1887	923	1522	558
112	HMA3 112M-2	6306-2Z/C3	1793	709	1468	384
	HMA3 112M-4		2148	1233	1709	793
	HMA3 112M-6		2602	1429	2078	906
132	HMA3 132S1-2	6308-2Z/C3	2453	1070	1996	613
	HMA3 132S2-2		2472	1052	2014	594
	HMA3 132S-4		3134	1626	2516	1008
	HMA3 132M-4		3174	1587	2555	968
	HMA3 132S-6		3562	2115	2824	1378
	HMA3 132M1-6		3620	2057	2882	1320
	HMA3 132M2-6		3673	2004	2936	1266

Frame size	Motor info	Bearing size	20.000 running hours		40.000 running hours	
			50 Hz		50 Hz	
			F (push)	F (Pull)	F (push)	F (Pull)
			(N)	(N)	(N)	(N)

Vertical mounting

160	HMC3 160M1-2	6309-2Z/C3	3218	1384	2620	786
	HMC3 160M2-2		3276	1325	2679	727
	HMC3 160L-2		3346	1255	2748	658
	HMC3 160M-4		4137	2080	3329	1272
	HMC3 160L-4		4234	1982	3427	1175
	HMC3 160M-6		4733	2680	3770	1717
	HMC3 160L-6	4827	2585	3864	1622	
	HMC3 160M1-2	6309/C3	3218	1384	2620	786
	HMC3 160M2-2		3276	1325	2679	727
	HMC3 160L-2		3346	1255	2748	658
	HMC3 160M-4		4137	2080	3329	1272
	HMC3 160L-4		4832	2580	3869	1617
	HMC3 160M-6		3327	1274	2729	677
	HMC3 160L-6	4827	2585	3864	1622	
180	HMC3 180M-2	6311-2Z/C3	4225	1823	3439	1037
	HMC3 180M-4		5319	2851	4258	1789
	HMC3 180L-4		5428	2742	4367	1681
	HMC3 180L-6		6230	3512	4964	2247
	HMC3 180M-2	6311/C3	4225	1823	3439	1037
	HMC3 180M-4		5319	2851	4258	1789
	HMC3 180L-4		5428	2742	4367	1681
	HMC3 180L-6		6230	3512	4964	2247
200	HMC3 200L1-2	6312-2Z/C3	4764	2179	3862	1277
	HMC3 200L2-2		6050	3330	4831	2111
	HMC3 200L-4		4621	1427	3835	641
	HMC3 200L1-6		7056	4129	5603	2676
	HMC3 200L2-6		7196	3988	5743	2536
	HMC3 200L1-2	6312/C3	4764	2179	3862	1277
	HMC3 200L2-2		4831	2111	3930	1209
	HMC3 200L-4		6287	3093	5069	1874
	HMC3 200L1-6		7056	4129	5603	2676
	HMC3 200L2-6		7196	3988	5743	2536

L10 Grease life 37100 h

L10 Grease life 32700 h

Frame size	Motor info	Bearing size	20.000 running hours		40.000 running hours	
			50 Hz		50 Hz	
			F (push)	F (Pull)	F (push)	F (Pull)
			(N)	(N)	(N)	(N)

Vertical mounting

225	HMC3 225M-2	6312/C3	4985	1958	4083	1056
	HMC3 225S-4		-	-	-	-
	HMC3 225M-4		-	-	-	-
	HMC3 225M-6		-	-	-	-
	HMC3 225M-2	6313-2Z/C3	-	-	-	-
	HMC3 225S-4		7066	3641	5675	2251
	HMC3 225M-4		7169	3538	5778	2147
	HMC3 225M-6		8199	4568	6540	2910
	HMC3 225M-2	6313/C3	5476	2449	4447	1420
	HMC3 225S-4		7066	3641	5675	2251
	HMC3 225M-4		7169	3538	5778	2147
	HMC3 225M-6		8206	4562	6547	2903
250	HMC3 250M-2	6313-2Z/C3	5662	2264	4632	1234
	HMC3 250M-4		-	-	-	-
	HMC3 250M-6		-	-	-	-
	HMC3 250M-2	6313/C3	5662	2264	4632	1234
	HMC3 250M-4		-	-	-	-
	HMC3 250M-6		-	-	-	-
	HMC3 250M-2	6314/C3	-	-	-	-
	HMC3 250M-4		8294	3913	6708	2327
HMC3 250M-6	9426		5129	7535	3238	
280	HMC3 280S-2	6314/C3	6536	2499	5362	1326
	HMC3 280M-2		6708	2327	5534	1154
	HMC3 280S-4		-	-	-	-
	HMC3 280M-4		-	-	-	-
	HMC3 280S-6		-	-	-	-
	HMC3 280M-6		-	-	-	-
	HMC3 280S-2	6317/C3	-	-	-	-
	HMC3 280M-2		-	-	-	-
	HMC3 280S-4		10284	8584	8354	6654
	HMC3 280M-4		10624	4233	8694	2303
	HMC3 280S-6		11631	6084	9330	3782
	HMC3 280M-6		11945	5770	9644	3468

Frame size	Motor info	Bearing size	20.000 running hours		40.000 running hours	
			50 Hz		50 Hz	
			F (push)	F (Pull)	F (push)	F (Pull)
			(N)	(N)	(N)	(N)

Vertical mounting

315	HMC3 315S-2	6317/C3	11693	5730	9430	3467
	HMC3 315M-2		11945	5479	9681	3216
	HMC3 315L1-2		12094	5330	9831	3066
	HMC3 315L2-2		12493	4930	10230	2667
	HMC3 315S-4		-	-	-	-
	HMC3 315M-4		-	-	-	-
	HMC3 315L1-4		-	-	-	-
	HMC3 315L2-4		-	-	-	-
	HMC3 315S-6		-	-	-	-
	HMC3 315M-6		-	-	-	-
	HMC3 315L1-6		-	-	-	-
	HMC3 315L2-6		-	-	-	-
	HMC3 315S-2	6319/C3	-	-	-	-
	HMC3 315M-2		-	-	-	-
	HMC3 315L1-2		-	-	-	-
	HMC3 315L2-2		-	-	-	-
	HMC3 315S-4		12348	4153	10204	2009
	HMC3 315M-4		12786	3714	10643	1571
	HMC3 315L1-4		13200	3301	11056	1157
	HMC3 315L2-4		13889	2612	11745	468
	HMC3 315S-6		14160	5516	11604	2960
	HMC3 315M-6		14455	5220	11899	2665
	HMC3 315L1-6		15139	4536	12583	1980
	HMC3 315L2-6		15783	3892	13227	1336

Frame size	Motor info	Bearing size	20.000 running hours		40.000 running hours	
			50 Hz		50 Hz	
			F (push)	F (Pull)	F (push)	F (Pull)
			(N)	(N)	(N)	(N)

Vertical mounting

355	HMC3 355M-2	6319/C3	10956	1258	9369	0
	HMC3 355L1-2		11493	721	9906	-
	HMC3 355M-4		15419	1081	13276	-
	HMC3 355L1-4		16051	449	13908	-
	HMC3 355M1-6		16713	2962	14157	406
	HMC3 355M2-6		17561	2115	15005	0
	HMC3 355L-6		19148	527	16592	-
	HMC3 355M-2	6322/C3	-	-	-	-
	HMC3 355L1-2		-	-	-	-
	HMC3 355M-4		17511	2453	14917	0
	HMC3 355L1-4		18143	1821	15549	-
	HMC3 355M1-6		19138	4667	16046	1575
	HMC3 355M2-6		19986	3820	16893	727
	HMC3 355L-6		21573	2232	18481	-
400	Please contact Hoyer					

Table 11

8 Frequency converter operation

By using a VFD with Hoyer motors, you get optimal operating conditions of your system. Not only will a VFD-solution increase energy savings, but also reduce application noise and thus give crucial improvements to the surrounding working environment. A VFD will secure a precise motor application control, which ensures optimal application performance and a reduction in mechanical stress on the system, thus extending the system lifetime.

When operating your motor with a frequency converter, please be aware of below.

8.1 Operating speed

Controllable operating speed will most likely lead to an optimized application performance and overall system efficiency. By using VFD control it is possible to drive the motor and application at a wide range of speeds. When controlling the speed of a motor, please take these general conditions into account.

- 1) When operating below nominal speed, the cooling capacity of the motor will be reduced and could result in potential overheating.
- 2) When operating above nominal speed, the output torque will be reduced, which can complicate the dimensioning of the motor for a given application.
- 3) When operating above nominal speed, the critical speed of the shaft-rotor must be taken into account, especially for larger motors with low pole numbers. For continuous speeds outside the values given in Table 12, please contact Hoyer.

Motor size	2 pole	4 pole	6 pole
71	6000	3600	2400
80	6000	3600	2400
90	6000	3600	2400
100	6000	3600	2400
112	4500	3600	2400
132	4500	2700	2400
160	4500	2700	2400
180	4500	2700	2400
200	4500	2300	1800
225	3600	2300	1800
250	3600	2300	1800
280	3600	2300	1800

315	3600	2300	1800
355	3600	2300	1800
400	3600	1800	1200
450	3000	1800	1200

Table 12: Maximum operating speed [RPM]

Please contact Hoyer for confirmation of speeds above 60 Hz for continuous operation. VFD-curves for Hoyer motors are available on <http://hoyermotors.com>.

8.2 Winding insulation

When using a VFD voltage peaks are generated which increases the electrical deterioration of the motor insulation system. To prevent deterioration and to extend the lifetime of the motor insulation system, reinforced insulation systems are recommended for VFD supply voltages above 500 V. In some cases, filters are also recommended at the output of the VFD's. Hoyer's three insulation systems are designed in accordance with IEC 60034-17 and IEC TS 60034-25, which states the voltage stress withstand capability as seen in below table.

Hoyer insulation system designation	Electrical specification
Hoyer standard insulation	1350 V @ 0.8 μ s
Hoyer reinforced insulation	1560 V @ 0.5 μ s
Hoyer premium reinforced insulation	2150 V @ 0.5 μ s

Table 13: The voltage stress withstand capability

8.3 Bearing deterioration in relation to VFD

Utilizing VFD control of an electric motor can introduce increased risk of bearing currents. Persistent bearing currents will often result in mechanical deterioration of the motor bearings and must therefore be avoided.

The following factors influence, but are not limited to, the arise of persistent bearing currents:

- Motor sizes and construction.
- Specific application and duty.
- Bearing types.
- VFD switching frequency and mode.
- VFD output filters.
- Grounding of the shaft either through the application or application bearings.
- Overall grounding installation and considerations re-

- garding high frequency currents.
- Effectiveness of protection to enhance electromagnetic compatibility (EMC)
 - EMC screened equipment suitable for VFD operation is recommended and could, among others, include:
 - Sufficient cable screening, cable gland connections, suitable high frequency earthing etc.

To reduce the risk of bearing currents and corresponding downtime of the motor application, please see the suggestions for motor applications operated with VFD's in the section 8.5 Hoyer VFD application suggestions.

8.4 Additional solutions for limitation of bearing currents

In special cases where bearing current still occurs, or for essential applications where optimised uptime is significant, additional actions may be recommended. Depending on application and installation requirements, the following advanced solution will ensure a high reliability:

- Grounding brushes can be mounted to ensure a good earthing connection between motor housing and shaft.
- Insulated bearing in NDE and DE
- Hybrid bearing with ceramic balls in NDE or DE.
- Combination of Hybrid bearing in NDE and brush in DE

Grounding brushes are installed outside the motor housing and makes the connection from stator to shaft. Brushes must periodically be inspected for wear and tear in order to ensure an optimized protection.

With insulated bearings mounted in drive-end and none-drive-end, the shaft is electrically insulated from the stator, meaning that no bearing current will run from stator to rotor. Bearings with ceramic balls are recommended as the most reliable solution.

Be aware of any bearings in the application, so that the bearing current does not pass through these when the motor bearings are insulated and a grounding brush is not used.

8.5 Hoyer VFD application suggestions

To ensure a reliable VFD- and motor operation, please take the suggestions listed in below table into account.

In general Hoyer recommends reinforced insulation systems and insulated bearings in NDE when the motor has a power-size above 75 kW or a supply voltage above 500 V. Common mode filters are recommended above 75 kW and dU/dt filters should be implemented when supply voltages surpasses 500 V. Hoyer can deliver all types of filters upon request.

Supply voltage	Power	Winding insulation	Motor bearings	Drive filters*
< 500 V	< 75 kW	Hoyer standard insulation	Standard bearings	No filter needed
	≥ 75 kW	Hoyer standard insulation	Insulated non-drive end bearing	Common mode filter
≥ 500 V	<75 kW	Hoyer reinforced insulation	Standard bearings	dU/dt filter
	≥ 75 kW		Insulated non-drive end bearing	dU/dt filter & common mode filter

*Common mode filters can generally be recommended in all motor sizes

Hoyer premium reinforced insulation system can be implemented upon request

Table 14: Hoyer motor recommendations to bearing current and filter mitigation with VFD control.

9 Operation

9.1 Considerations

Safety equipment must be used during installation and operation at the site. The motor is only intended for fixed installation and use by qualified personnel. Motors must only be used according to the rated nominal values on the motor nameplate.

9.2 Checklist

Check the following before powering on the motor:

- All mechanical and electrical connections are ready for start-up.
- The insulation resistance values correspond to the data in Section 4.3.
- The earthing connection is fitted correctly.
- Couplings and transmissions are sufficiently aligned to allow the machinery to run smoothly.
- The motor is operating within the permissible ambient temperature range.
- The operation data corresponds to the nameplate.
- The monitoring equipment is connected correctly and fully functional.
- Make sure the motor is not running faster than the permissible speed for the application.
- The output power corresponds to the duty type.
- Screws and bolts are fitted and tightened properly.
- The rotor can turn in response to an external force without applied power.
- Protective parts are removed from the motor shaft.
- The external fans rotate in the specified direction.
- All brakes/switches are fully functional.

9.3 Cooling

Check the following with regard to cooling:

- The motor has sufficient airflow.
- No nearby objects radiate additional heat.
- Direct sunlight does not add additional heat.

For flange mounted motors (e.g. B5, B35, V1), make sure that the construction of the machinery allows sufficient air flow along the outer surface of the motor housing. Table 15 shows the minimum distance from the motor fan cover to the wall or other objects (see Figure 4 for reference).

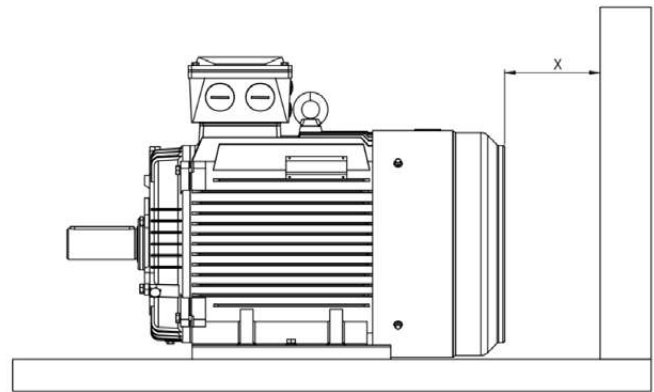

Minimum clearance to the wall

Figure 4 Minimum distance to wall/objects

IEC frame size	Minimum distance from fan cover to wall (X) in mm
63	35
71	35
80	40
90	45
100	50
112	55
132	65
160	80
180	90
200	100
225	120
250	125
280	140
315	155
355	175
400	215
450	225
500	260
560	290
630	325

Table 15 Minimum distance from wall or objects

For special motors with water cooling, the ambient temperature must be at least +5°C to avoid motor damage due to water freezing in the cooling tubes. This also applies to these motors in storage. Alternatively, the cooling tubes can

be filled with a mixture of water and ethylene glycol. Contact Hoyer regarding the proportion of the mixture.

9.4 Motor operation with a VFD

Before operating a motor with a VFD, ensure that the parameters of the VFD have been configured correctly according to the instructions of the VFD manufacturer and the motor parameters. If the motor does not run smoothly or produces abnormal noises, switch off the supply and make sure the motor is de-energised, and then find the root cause of the problem.

9.5 Operating speed

When operating a motor above its nominal speed, ensure that the motor speed does not exceed the maximum permissible speed for the application and the maximum permissible speed of the motor. Maximum speeds are defined by IEC 60034-1 in Table 16. Higher-speed motors are available upon request; contact Hoyer Motors for more information.

Frame number	2 pole	4 pole	6 pole
≤ 100	5200	3600	2400
112	5200	3600	2400
132	4500	2700	2400
160	4500	2700	2400
180	4500	2700	2400
200	4500	2300	1800
225	3600	2300	1800
250	3600	2300	1800
280	3600	2300	1800
315	3600	2300	1800

NOTE: The above values may have to be reduced to meet the requirements of IEC 60079

Table 16 Maximum permissible rotor speeds

10 Maintenance

10.1 General

Motors must be maintained. Neglecting motor maintenance will degrade the performance and lifetime of the motor. Proper installation, electrical/thermal protection and correct maintenance of a motor result in optimal motor life.

Inspect the motor at regular intervals, keep the motor clean, ensure a free flow of ventilation air, and check the condition of shaft seals and replace them as necessary. It is important that the shaft seals are always intact. Check the electrical connections and mechanical mounting, and tighten terminals and fasteners as necessary.

All maintenance work on motors must be performed by suitably qualified personnel.

- Voltage can be present inside the terminal box when the motor is not running, for example if the motor has a heating strip or direct winding heating. Always switch off auxiliary power and protect against reactivation before carrying out maintenance on the motor.
- A motor operating from a VFD can be electrically live even when it is not running.
- Capacitors in single-phase motors can retain a charge over the motor terminals even when the motor is not energised.
- Be aware of rotating parts.
- Grease can cause eye and skin irritation. Follow the safety instructions of the grease manufacturer.
- Do not exceed the maximum permissible speed of the motor.
- Do not exceed the maximum operating temperature of the grease and the bearings.

Clean the exterior of the motor at regular intervals, taking the IP rating of the motor into account.

If the motor operates in an environment where the fan cover ventilation openings or the cooling fins can be obstructed, the obstructions must be removed. Any deviation from nominal motor performance or irregular motor operation (e.g. increased motor current, temperature above the permitted value for the stated insulation class, increased vibration, unusual noises, noticeable insulation odour, tripped motor protection devices, etc.) must be investigated carefully to determine the cause.

For spare parts, contact Hoyer Motors with the exact motor type and serial number from the motor nameplate.

10.2 Bearings and re-greasing

The standard bearing assembly is single row deep-groove ball bearings (ZZ or 2RS) with clearance C3. The bearings (ZZ or 2RS) are lubricated for life. Bearing replacement in the event of failure or noise, or at regular service intervals, must be performed with adequate tools and without applying excessive force or hammering.

Open bearings must be re-greased. Open the grease outlet if the plug has been closed. It is recommended to grease for the first time during commissioning. The following applies in general for both lifetime lubricated bearings and re-lubricated bearings:

- With 60 Hz operation the grease lifetime will be reduced by approximately 20%.
- The values for vertically mounted motors are half of the stated values. The values in the tables are based on an ambient temperature of 25°C (Table 17 and Table 18).
- The grease lifetime is reduced by 50% for every 15 K rise in bearing temperature.
- Operation at higher speeds, e.g. with a variable speed drive, makes shorter regreasing intervals necessary. Doubling the speed will typically reduce the grease lifetime by 50%.

If re-greaseable bearings are fitted, observe the re-greasing intervals in Table 18, Re-greasing intervals and amounts. Re-greasing of the bearings while the motor is in operation is possible via the grease nipples on the bearing shields, using a hand grease gun for a consistent grease amount. Hoyer recommends the following greases for use in the ambient temperature range of -20°C to +150°C: Polyurex EM2 or other polyurea based grease with a drip temperature of 180-200°C. If other grease types are used it must have the same or better NLGI grade and consist of same thickener base, otherwise compatibility must be checked with grease manufacturer.

The bearing size and type are shown on the nameplate, and an overview is provided in Section 6.2. Motor types HMA3 and HMA3 are equipped as standard with lifetime greased bearings in frame sizes up to 180 with cast iron and up to 132 with aluminium. Motor types HMA2 and HMC2

are equipped as standard with lifetime greased bearings in frames size up to 225. Motor types MS and Y2E are equipped as standard with lifetime greased bearings in frame sizes up to 160. Typical operating hours for lifetime lubricated bearings are shown in Table 17, Lubricated bearing lifetime. It is important that the shaft seals are intact.

Frame size	Poles	Typical lifetime
50-160	2-8	40,000 h
180	2	35,000 h
200	2	27,000 h
225	2	23,000 h
180-225	4-8	40,000 h

Table 17 Lubricated bearing lifetime

Motors with re-greaseable bearings are equipped with a greasing data plate. If the data plate is missing, or the information on it unreadable, please use the re-greasing intervals shown in Table 18, Re-greasing intervals and amounts. Values on Table 18 are calculated based on worst case scenarios so it fits on a wider application range, whereas values on the nameplates are calculated for the respective motor specification. As a result, the data on the motor greasing plate can deviate from the values on Table 18. Different motor items, with the same bearing size and type may also have different re-greasing periods for the same reason. For missing greasing data plate or any doubt please contact Hoyer.

Frame size	Grease (g)	2-pole (h)	4-pole (h)	6-pole (h)	8-pole (h)
160	20	4200	7000	8500	8500
180	20	4200	7000	8500	8500
200	25	3100	6500	8500	8500
225	25	3100	6500	8500	8500
250	35	2000	6000	7000	7000
280	35	2000	6000	7000	7000
315	50	1500	5500	6500	6500
355	60	1000	4000	5000	6000
400	80	800	3000	4000	6000

Table 18 Re-greasing intervals and amounts

A suggestion for re-greasing procedure can be as follows:

1. Remove the fan cover (If grease inlet and outlet is not accessible through the fan cover in NDE).
2. Open the dust protection cap of the grease nipple inlet and the grease outlet both for DE and NDE.
3. Check if the grease nipple is clean and free of dirt.
4. Remount the fan cover (If grease inlet and outlet is not accessible through the fan cover in NDE).
5. Run the motor till it has reached its hot condition normally 1-2 hours (skip this point for the first startup).
6. Use manual or automatic grease gun and add the specified grease type and amount while the motor is running (N.B. the fan cover must always be fixed on the motor when its running).
7. Take of the grease gun and let the motor run in order to get the old grease out approx. 1-2 hours.
8. Stop the motor and wait for complete standstill.
9. Dismount the fan cover If grease inlet and outlet is not accessible through the fan cover in NDE).
10. Close the dust protection cap of the grease nipple inlet and the grease outlet.
11. Clean up the old grease.
12. Remount the fan cover (If grease inlet and outlet is not accessible through the fan cover in NDE).

Note: Due to danger it is forbidden to get in contact with rotating or live parts under the maintenance. At the first startup for the motor the bearings must be greased before startup, else the bearings will be damaged.

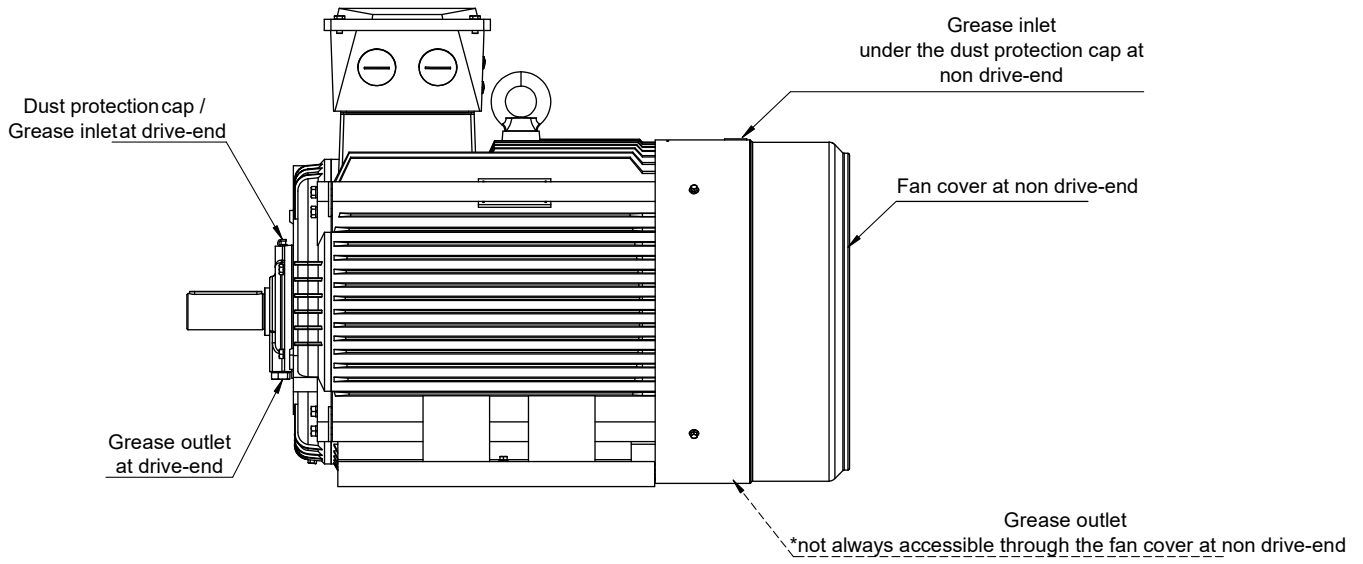

Figure 5 Re-greasing procedure

11 Disposal and environmental protection

11.1 Product disposal information

In accordance with Directive 2012/19/EU regarding waste electrical and electronic equipment (WEEE), Hoyer motors are marked with the crossed-out wheeled bin symbol shown in Figure 6.

The symbol can be found on the motor nameplate or on the packaging and relevant documentation.



Figure 6 Symbol WEEE marking

The symbol indicates that electrical and electronic equipment must not be disposed together with ordinary domestic waste and must be treated as WEEE. Electrical and electronic equipment (EEE) contains materials, components and substances that may be hazardous and can present a risk to human health and the environment when waste electrical and electronic equipment (WEEE) is not handled correctly.

More detailed information is available from the relevant local authority.

11.2 RoHS and REACH

All motors from Hoyer Motors comply with the RoHS directive and the REACH regulation. Official documents can be downloaded from the Hoyer Motors website <https://hoyermotors.com>

11.3 Electric motors

Electric motors are manufactured from ferrous metals (steel, cast iron), non-ferrous metals (copper, aluminium) and plastics. At the end of their service life, motors must be disposed of according to international and local regulations. Waste handling facilities must be licensed and must comply with the environmental requirements of the member states they are located in. Figure 7 shows the main components of a three-phase motor. Table 19 lists the motor materials.

11.4 Packaging material

The packaging of motors from Hoyer Motors consists of cardboard, plastic, steel and wood. These materials are recyclable, and Hoyer recommends recycling them according to the national regulations.

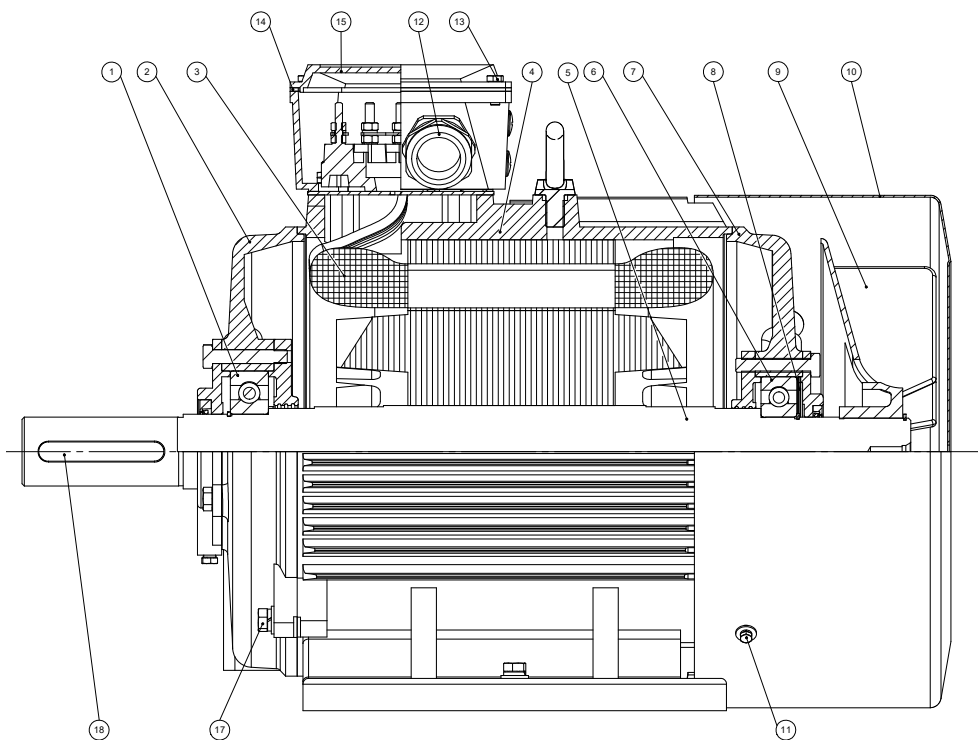

Figure 7 Main components of a three-phase motor

Item	Description	Material
11, 17	Fasteners	Steel
	Oil seals	Rubber and steel
2, 7	Flanges	Aluminium/cast iron/steel
15	Terminal box cover	Aluminium/cast iron
14	Gaskets	Rubber
16	Nuts, lugs, studs, washers	Brass/steel
16	Terminal board	ABS/ceramic/resin
21	Terminal box	Aluminium/cast iron
12	Cable glands or blind plugs	Brass/steel/plastic
4	Frame	Aluminium/cast iron/steel
3	Stator package	Copper/steel/plastic
8	Preload washer	Steel
18	Key	Steel
5	Rotor assembly	Steel and aluminium
	Shaft	Steel
1, 6	Bearing	Steel/steel and rubber
9	Fan	Plastic/aluminium
10	Fan cover	Steel
19	Feet	Aluminium/cast iron
20	Bearing caps	Cast iron/steel

Table 19 Components of a three-phase motor

HOYER

EXCEEDING EXPECTATIONS

Hoyer Motors, Motor Manual, December 2021

Head Offices

Denmark
Over Hadstenvej 42 · DK-8370 Hadsten
T +45 86 98 22 55 · F +45 86 98 17 79
hoyermotors@hoyermotors.com

China
19 Jingwu Middle Road · Beilun District
Ningbo 315821 · Zhejiang
T +86 21 8036 4698 · F +86 574 2628 1573
hoyermotors@hoyermotors.cn

Branch Offices

Germany
Landsberger Straße 155 · 80687 München
T +49 89 700 88 235 · F +49 89 543 56 333
germany@hoyermotors.com

Sweden
Liljeholmsstranden 5 · PO box 44017
SE-100 73 Stockholm
T +46 8 446 877 13 · F +46 8 446 877 20
sweden@hoyermotors.com

Benelux
Vasteland 78 · 3011 BN, Rotterdam
T +31 10 420 35 20 · F +31 10 420 44 51
benelux@hoyermotors.com

Norway
Torvet 1 · 3256 Larvik
T +47 33 18 00 11
norway@hoyermotors.com

Poland
Stanisława Konarskiego 11 · 33-100 Tarnów
T +48 668 924 448
poland@hoyermotors.com

Korea
302ho · Code square, 3150-1
Daejeo 2-dong · Gangseo-gu · Busan
T +82 51 944 1268 · F +82 51 996 0252
korea@hoyermotors.com

Japan
Mizunobu Bldg 7F, 1-11-1 · Kitasaiwai
Nishi-ku Yokohama
T +81 35 571 1517
japan@hoyermotors.com

USA
Hoyer Inc · 5826 Cheswood
Houston TX 77087
wind@hoyermotors.com