

ALLFUEL®

AFI SERIES

Screw pump

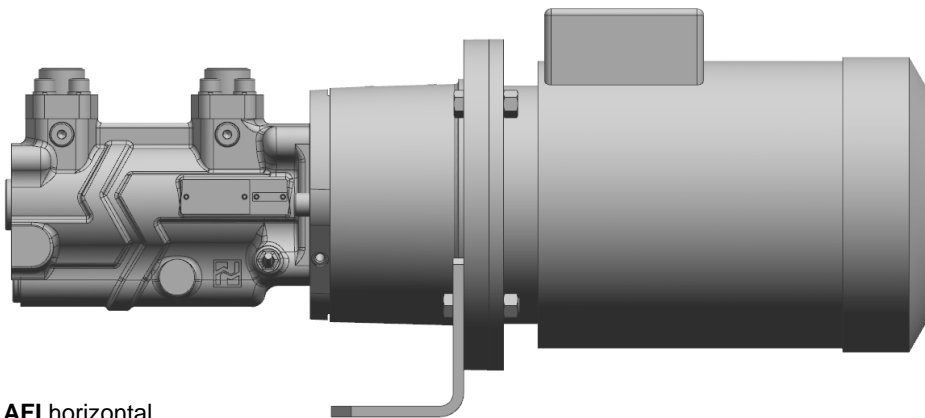

AFI horizontal

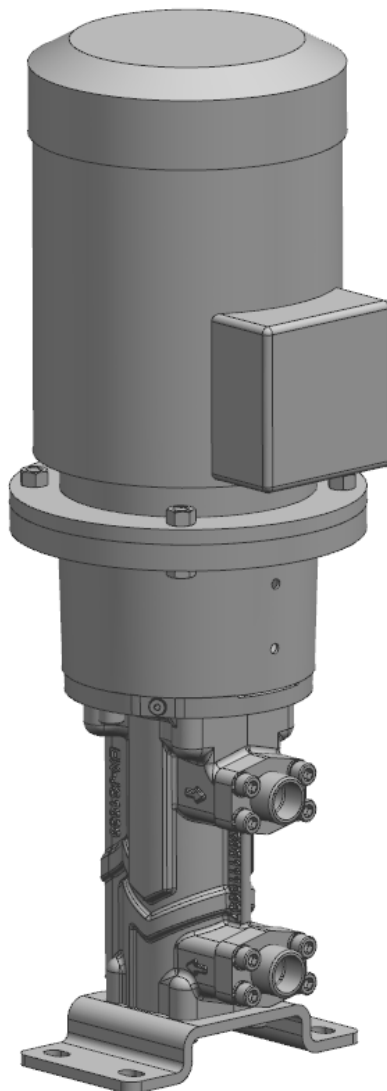

AFI vertikal

Utilization

For pumping heating oils, fuels (including low-sulfur ship fuel and marine diesel), lubrication oils, hydraulic oils or other lubricating liquids. The pumped liquids may not contain any abrasive components nor chemically attack the pump material.

Main field of application

ALLFUEL pumps are employed as transfer, booster and burner operation pumps in oil fired systems, as transfer pumps in (marine) fuel systems, as feeder and filling pumps in tank systems and as lube-oil pumps in virtually all areas of industry. They are also used in oil hydraulic systems of all types.

Design

Single pump/motor assembly in compact design; vertical and horizontal configuration without integrated filter.

Abbreviation

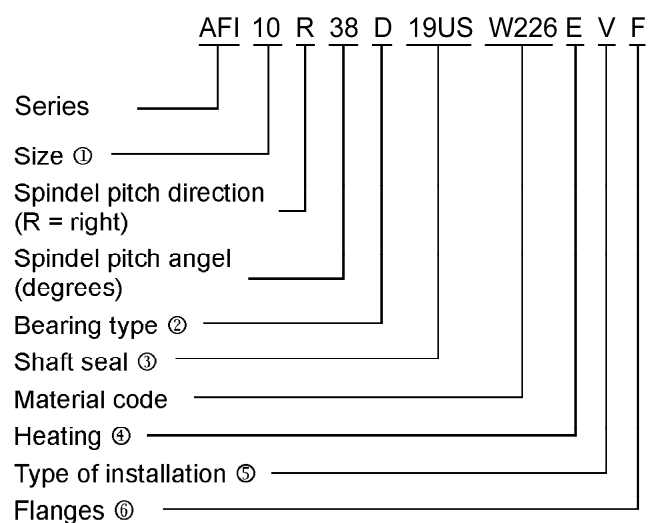

① Theoretical capacity Q[l/min] at 1.450 1/min and 46-degree pitch angle.

② D = antifriction bearing outside.

③ Unheated, uncooled mechanical shaft seal.

④ Version with electric heating of mechanical seal available at additional charge.

⑤ V = vertical; H = horizontal.

⑥ F = counter flange; A = adapter flange.

Structural design

Internal bearing, three screw, self priming screw pump. Together with the rotor housing, bearing, mechanical seal, and pump cover, the hardened and polished screws form an insert unit that can be exchanged quickly and easily. The drive spindle is hydraulically balanced. A special screw design absorbs the axial thrust of the idler screws. It is hydraulically driven. Only the torque resulting from liquid friction is transferred to the thread flanks. The thread flanks are therefore virtually free of loads and are not subject to wear. The pumped liquid lubricates all sliding parts and can be categorized as full fluid friction. The radial and axial bearing of the drive screw is provided by a groove ball bearing. A mechanical seal is used as the shaft seal. A return bore connects the seal chamber and the suction area to each other. As a result, only suction pressure acts on the shaft seal, regardless of discharge pressure. When a complete pump/motor assembly is delivered, a pump bracket connects the pump to the drive motor. Three sizes and various screw pitches ensure fine gradation of the entire flow rate range. The ALLFUEL family is designed with an insert unit consisting of a pre-assembled unit with liner, spindle set, mechanical seal, bearing and cover. In case of changing operation condition which request a different material combination or in case of replacement this insert unit can be implemented quickly and easily without dismantling the pump housing from the pipe works (process design). The insert unit fits into all existing ALLFUEL pump-housings as well as into pump-housings of the predecessor SPF-family (and all correlated derivates).

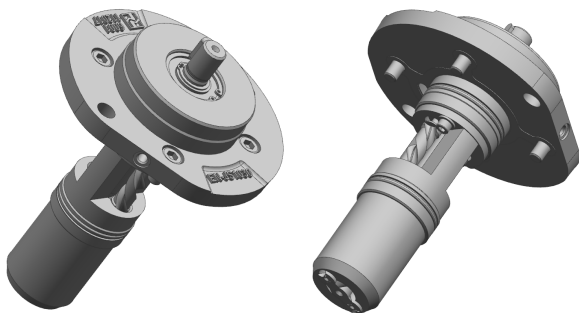

Functionality

Specially shaped thread flanks cause the three spindles to form sealed chambers; rotation of the spindles then causes the contents of the chambers to move continuously in the axial direction from the pump's suction side to its pressure side. Despite rotation of the spindles, no turbulence results. The uniform chamber volumes eliminate crushing forces.

Performance data

Capacity ①	Q	up to 112 l/min
Suction pressure	p_s	up to 6 bar
Discharge pressure ②	p_d	up to 40 bar
Liquid temperature ③	t	up to 150 °C
Viscosity range	ν	1 up to 750 mm ² /s

① at $n = 2.900$ 1/min and $\nu = 750$ mm²/s.

② Refer to the individual reference curves for the achievable pump pressure in relation to viscosity and rotational speed. Pressure specifications are applicable only to nearly static pressure loads. Please inquire about dynamically alternating pressure loads.

③ Consultation required if temperatures higher.

Filter and twin units

A separate system filter is essential when pumping oil with these no-filter AFI pumps. However, these pumps are also available with an integrated radial screen filter (AFI-F version) for protection against contamination. Filter mesh size 0,4 mm. Refer to document number 488083 for more information. Twin units (version AFI-T) are provided when a reserve pump is required. Refer to document number 488083 for more information.

Heating

If heating is required, these pumps can be delivered with electric heating cartridges for the mechanical seal chamber (subject to additional cost)

Pump size	Connection for	Heating cartridge output (Pressure side)
10	230 V	200 W
20	230 V	200 W
40	230 V	300 W

Heating capacity is dimensioned so that when outlet temperature is 20 °C heating time of 60 minutes will be adequate for highly viscous liquids. When temperatures are lower, a corresponding longer heat-up time will be required. Heating is not designed to achieve noticeable higher liquid temperatures during operation. To avoid potential damage to the bearing, do not exceed the permitted temperature of the pumped liquid.

Leaks

Formation of a lubricating film between the sliding surfaces is the most important factor in the functionality of a mechanical seal. This film is formed by the liquid being sealed. This "standard leak" of a few ml/h is essential for maintaining lubrication of the sliding surfaces. Absence or inadequate formation of a lubricating film is a common cause of damage.

When pumping liquids with low volatility, such as HFO, the user must therefore expect increasing deposits on the atmosphere side as time passes. As a result, it is physically not possible to achieve a 100% seal with a mechanical seal. If this is not acceptable, the magnetically-coupled version of ALLFUEL will be the right choice. Refer to document number .. for more information.

Flanges and connections

Feed and pressure ports as counter flange based on SAE (SAE J518C, hole pattern 3000 PSI).

Connections at present: E7 Venting of pump
H7 Heating cartridge
M1, M2, Pressure gauge.
Temperature gauge

Shaft seal

The shaft is sealed with a maintenance-free, unbalanced mechanical seal.

<u>Part name</u>	<u>Material design</u>
Rotating ring	silicon carbide
Counter ring	silicon carbide
Seal ring	peroxide cross-linked FKM
Spring	CrNiMo steel
Metal parts	CrNiMo steel

Noise level and pulsation

The design and operation of the screw pump enable a very low noise level and virtually pulsation-free pumping.

Overload protection

A pressure-relief valve is integrated into each pump as a means of overload protection. Its standard trigger pressure is set to approximately 10% above the working pressure. Please make sure your order specifies if a different trigger pressure is desired.

Installation

To avoid air trapped inside the pump, the pump may not be installed with the flanges pointing down. When installed vertically, a “motor down” arrangement is not permitted for safety reasons. In addition, the vent screw (160) may not point down.

Drive

A motor bracket facilitates connection of a wide variety of electric motors or other drive units. The following motor versions are normally provided with delivery of complete pump/motor assemblies:

Surface-cooled three-phase squirrel-cage motors, IMV 1 design type, IP 55 protection class according to IEC standard, insulation class F utilized according to B, output

and main dimensions according to DIN EN 50347. Motors configured for 50 Hz may also be operated in 60 Hz networks.

Power is transferred over an elastic coupling. Additional radial forces may not act on the drive spindle.

Explosion protection



The pump fulfills the requirements according to EU explosion-protection directive 2014/34/EC (ATEX 100a) for devices in device class II, category 2 G. Classification into temperature classes according to DIN EN 13463-1 depends on the temperature of the pumped liquid. Refer to the proposal or order documentation for the maximum permissible liquid temperature for the respective temperature classes.

Note: When operating the pump in category 2, suitable measures must be provided to prevent impermissible warming of the pump surfaces in the event of disturbance.

Materials

Denomination	Material design			
	W226 ①	W226E ①	W228 ②	W228E ②
Pump casing	EN-GJS-400-15		EN-GJS-400-15	
Casing insert	Aluminium	Aluminium	EN-GJL-250	EN-GJL-250
Pump cover end drive	EN-GJS-400-15	EN-GJS-400-15	EN-GJS-400-15	EN-GJS-400-15
Drive screw	Steel	Steel	Steel	Steel
Idler screw				

① Recommended material for all liquids incl. HFO up to 40 bar (except: Low Sulphur MGO / MDO)

② Recommended material for critical liquids up to 40 bar (e.g. HFO, Low Sulphur MGO / MDO)

NPSH – values [m]

NPSH req. for the pump without filter

AFI	Speed 1/min											
	950 / 1.140			1.450 / 1.750			2.900			3.400		
	Kinematic viscosity mm ² /s											
	3-40	150	750	3-40	150	750	3-40	150	750	3-40	150	750
10-28	2,5	2,8	3,2	2,5	2,9	3,6	2,5	2,9	4,2	2,6	3,1	4,3
10-38	2,5	2,8	3,6	2,5	2,9	3,9	2,5	3,1	4,6	2,6	3,3	5,1
10-46	2,5	2,9	3,9	2,5	3,0	4,2	2,6	3,3	5,1	2,8	3,5	6,6
10-56	2,5	2,9	4,3	2,5	3,1	4,5	2,8	3,7	7,3	3,1	4,1	7,0
20-38	2,5	2,9	3,9	2,5	2,9	4,1	2,5	3,2	5,0	2,7	3,5	5,6
20-46	2,5	2,9	4,2	2,5	3,1	4,4	2,7	3,5	6,2	3,0	3,9	7,0
20-56	2,5	3,0	4,5	2,5	3,3	5,1	3,2	4,1	7,2	3,6	4,6	9,1
40-38	2,5	2,9	3,8	2,5	3,1	4,3	2,7	3,5	5,6	2,9	3,8	6,3
40-46	2,5	3,0	4,2	2,6	3,3	4,8	3,0	4,0	6,8	3,4	4,4	7,8
40-54	2,5	3,2	4,8	2,7	3,6	5,4	3,6	4,7	8,2	4,2	5,5	9,7

Assembly AFI

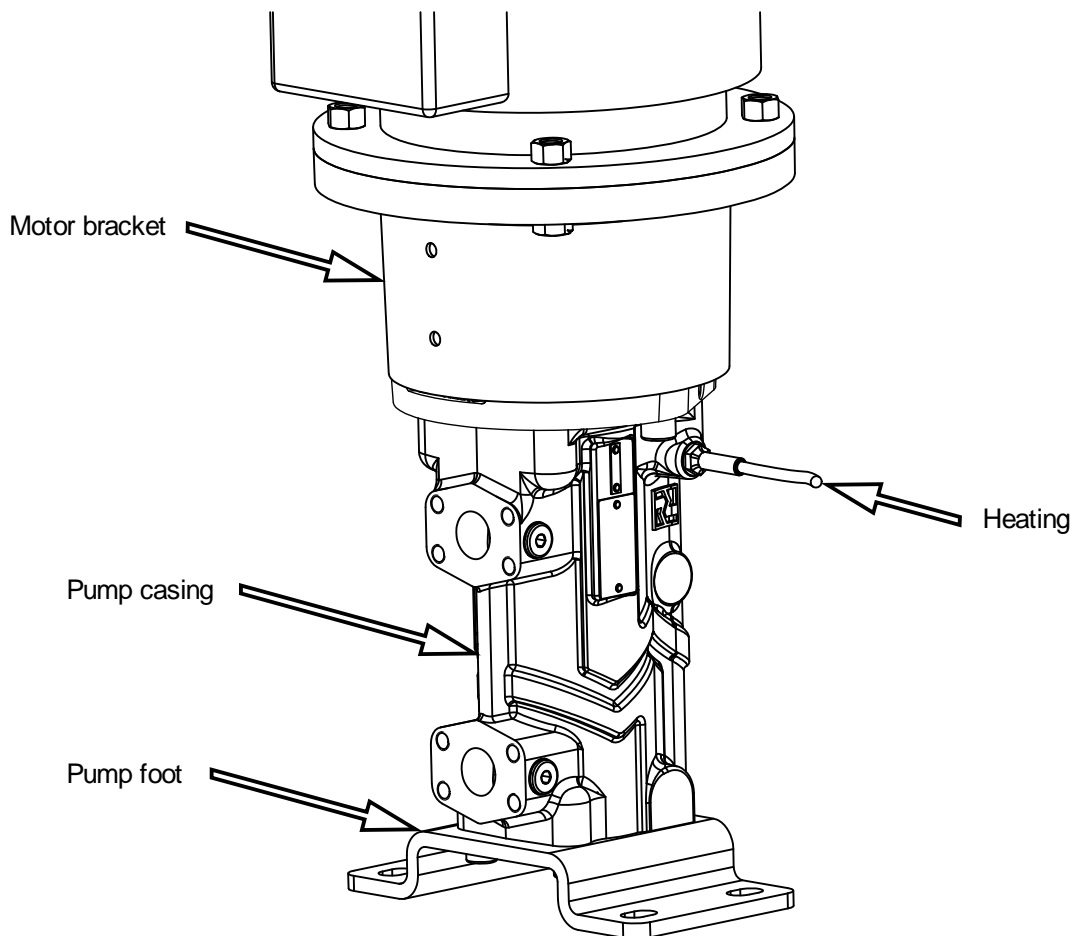
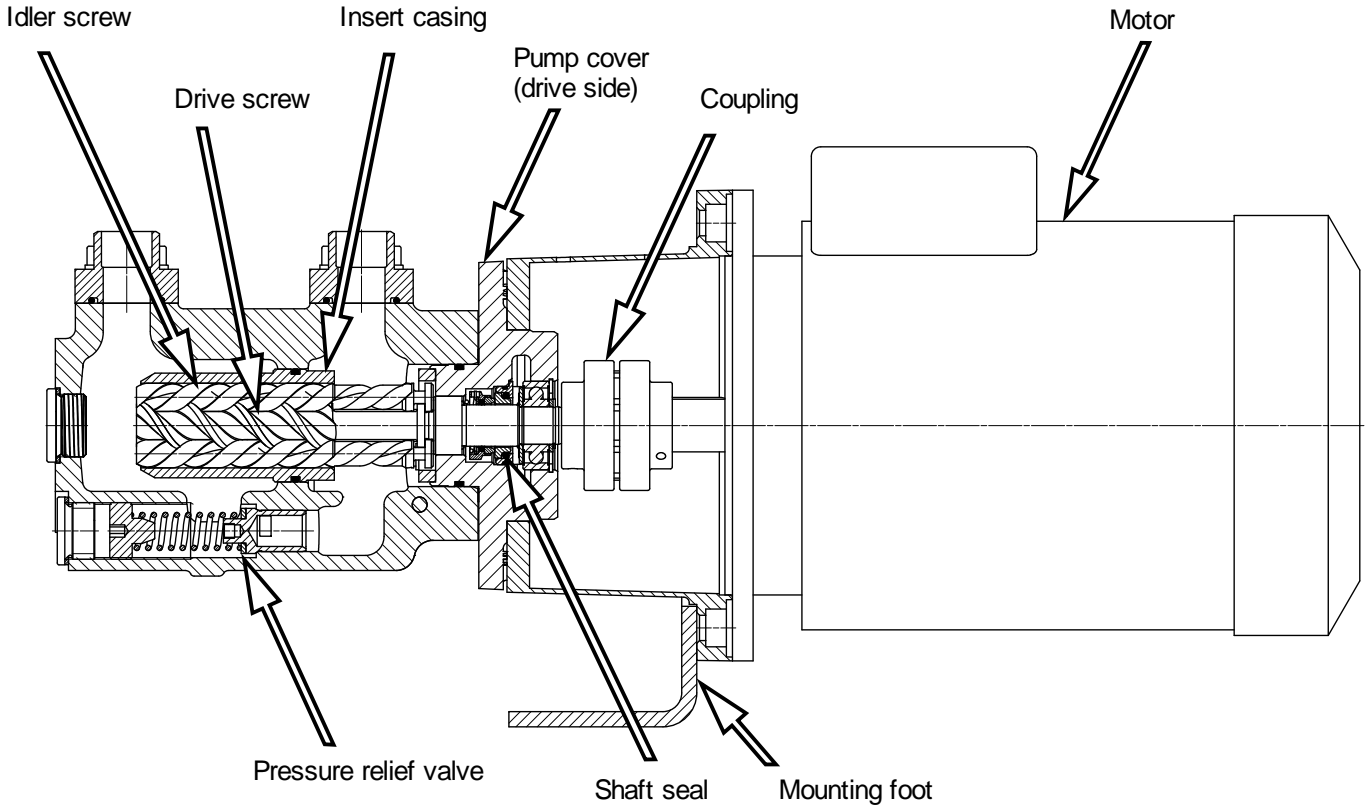

Main dimensions AFI
AFI horizontal configuration

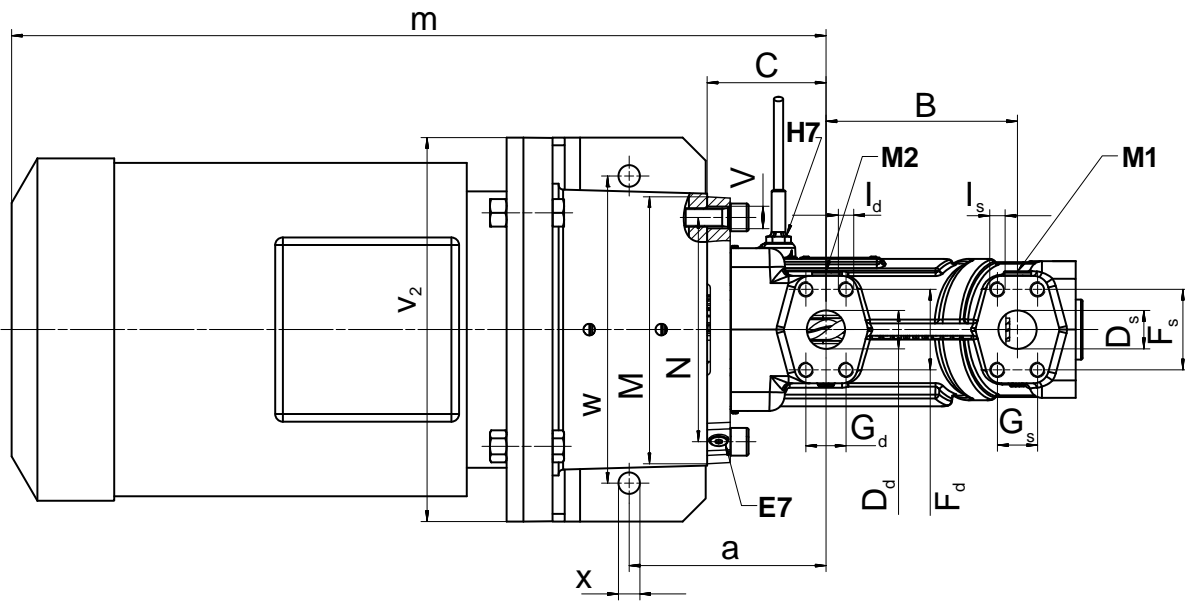
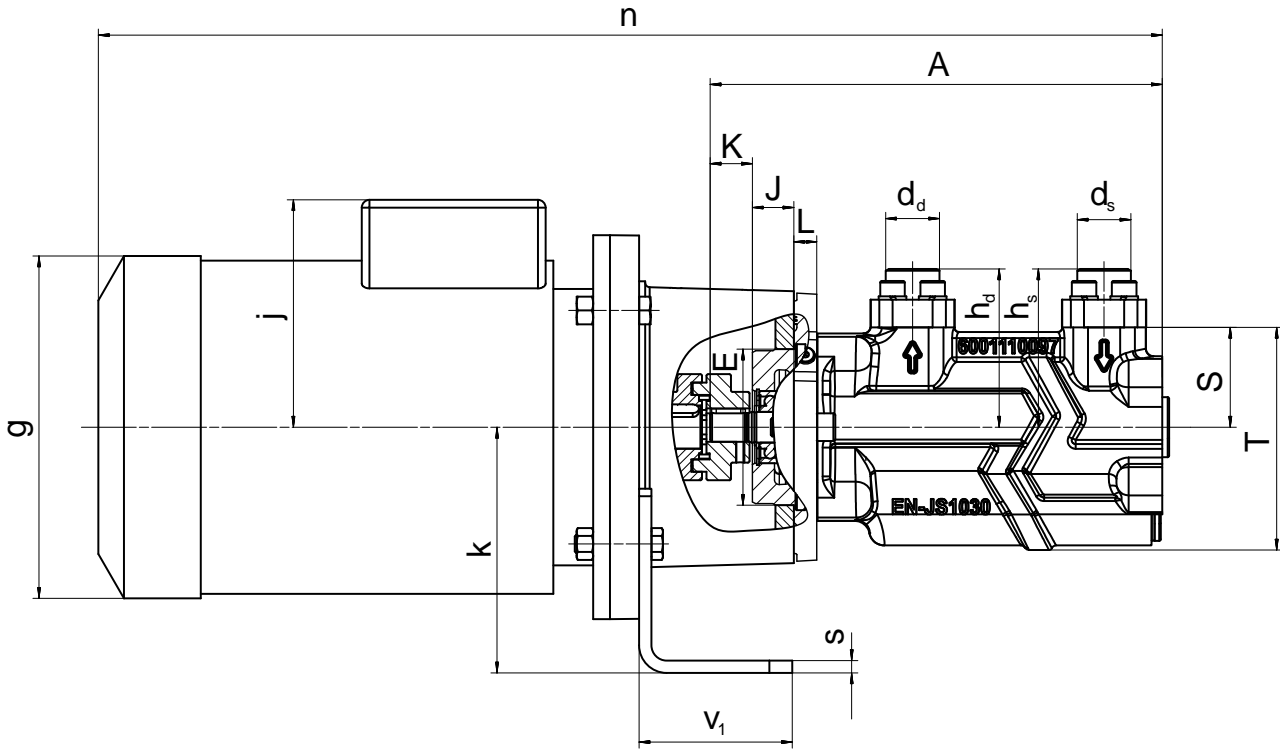

Shaft end

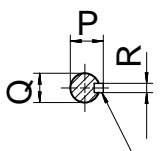

key acc.to
DIN 6885

Main dimensions AFI
AFI vertical configuration

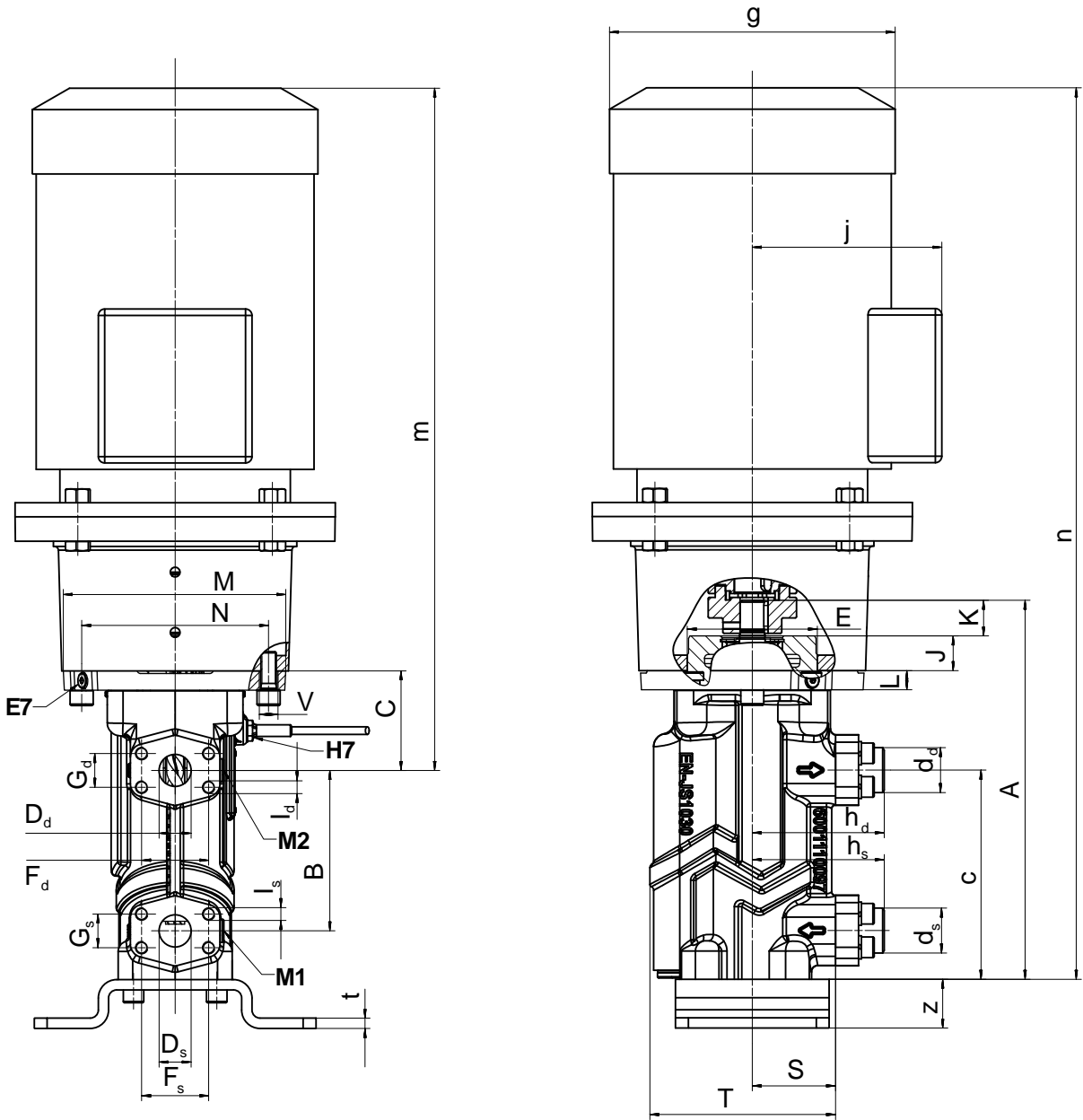

Pump foot

Main dimensions AFI

AFI size	Pump dimensions														
	A	B	C	E	J	K	L	M	N	P	Q	R	S	T	V
10	247	110	55,5	82,55 _{-0,05}	19,4	21,6	13	130	106	16	14 _{j6}	5	60	132	11
20	293,5	125	77,5	101,6 _{-0,05}	27	26	15	175	146	21,5	19 _{j6}	6	65	145	14
40	342,5	135					17						80	164	

AFI size	Motor size	Unit dimensions									
		a	c	e ₁	e ₂	f ₁	f ₂	g ^②	j ^②	k	m ^②
10	80	89,5	150,5	120	200	84	160	162	209	140	452
	90S							181	218		496
	90L							202	223		546
	100L							227	238		571
20	90S	151,5	163	120	220	84	180	181	218	160	558
	90L							202	223		564
	100L							227	238		571
	112M							266	278		683
40	90L	151,5	212	120	240	84	200	181	218	160	558
	100L							202	223		564
	112M							227	238		571
	132S							266	278		683
	132M							320	314		862
	160M							415 ^③	235		862

AFI size	Motor size	Unit dimensions											
		n ^②	s	t	v ₁	v ₂	w	x	y ₁	y ₂	z		
10	80	602	8	8	100	200	160	14	14	7	38		
	90S	646				250	200						
	90L	696				200	160						
	100L	721				250	200						
20	90S	721	8	8	100	250	200	14	14	7	38		
	90L	727				120	300					250	14,5
	100L	734				200	160						
	112M	776				250	200						
40	90L	770	8	8	100	200	160	14	14	7	38		
	100L	776				120	300					250	14,5
	112M	783				200	160						
	132S	895				250	200						
	132M	1074				305	350					300	18 ^③
	160M	18				305	350					300	18 ^③

Connections			
AFI size	Venting	Heating Cartridge	Pressure gauge
		E7	H7
10	M8x1	M12x1	G 1/8
20 and 40			G 1/4

AFI size	Connection dimensions													
	SAE-suction flange ①							SAE-pressure flange ①						
	Inch	D _s	F _s	G _s	I _s	d _s	h _s	Inch	D _d	F _d	G _d	I _d	d _d	h _d
10	¾	22	47,63	22,23	4 x M10	28	96	¾	22	47,63	22,23	4 x M10	28	96
20	1	25	52,37	26,19		35	103	1	25	52,37	26,19		35	103
40	1 ¼	32	58,72	30,18		43	121	1	25	52,37	26,19		35	118

Dimensions in mm,
Direction of rotation:
Clockwise as seen from
the drive side.

- ① SAE J518C, hole pattern 3.000 PSI.
- ② Dimensions are reference only and may deviate depending on motor manufacturer.
- ③ Foot mounted design on pump size 40 for motor size 160M with 4 screws, see ALL2CAD for dimensions.

Benefits

► **Economical use of space**
The installed pump requires little space.

► **Flawless start-up**
The vent screw ensures the best possible venting of the mechanical seal chamber each time the pump is started, even when installed vertically.

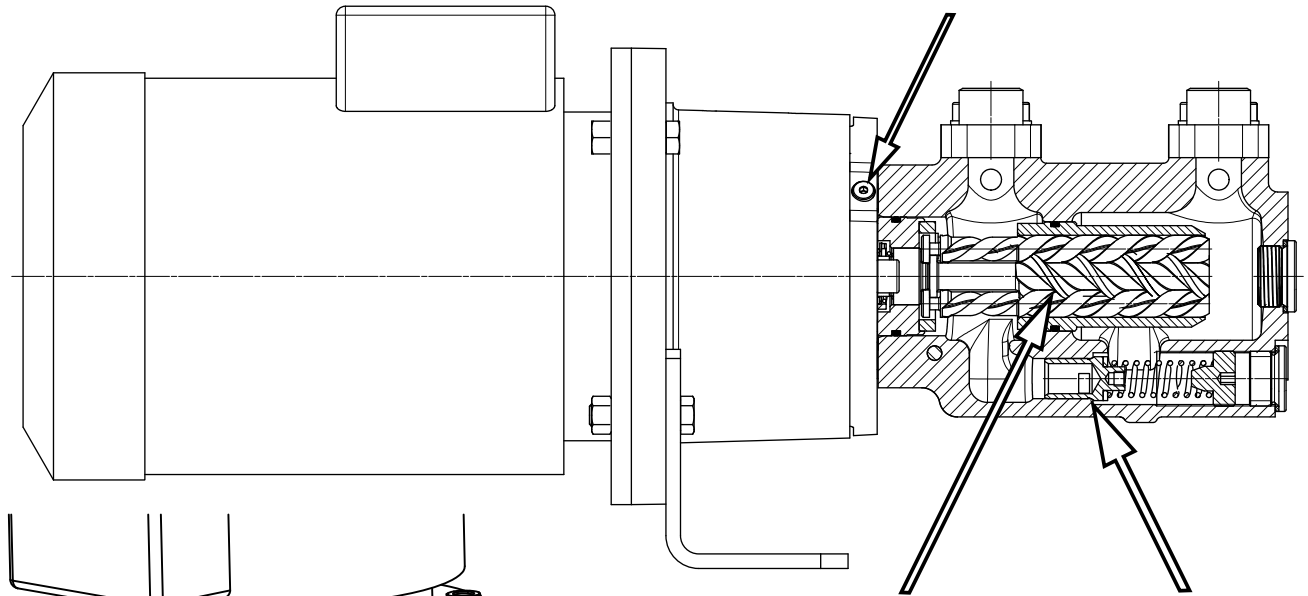

► **Reliable process stability**
Specially-shaped thread flanks produce virtually pulsation-free, low-noise pumping action.

► **Outstanding reliability**
The conical valve provides permanent protection against impermissibly high pressures.

► **Impressive service life**
Hydrodynamic axial thrust compensation minimizes loads on the screws and extends service life.

► **Flawless pump starting**
Optional heating of the casing ensure that the pump starts without issue even when the ambient temperature is low.

► **Extraordinary flexibility**
A wide range of available materials makes it possible to adapt to special operating conditions and various liquids.

► **Versatile and adaptable**
The ability to install the pump horizontally or vertically lets the operator adapt to even small spaces.

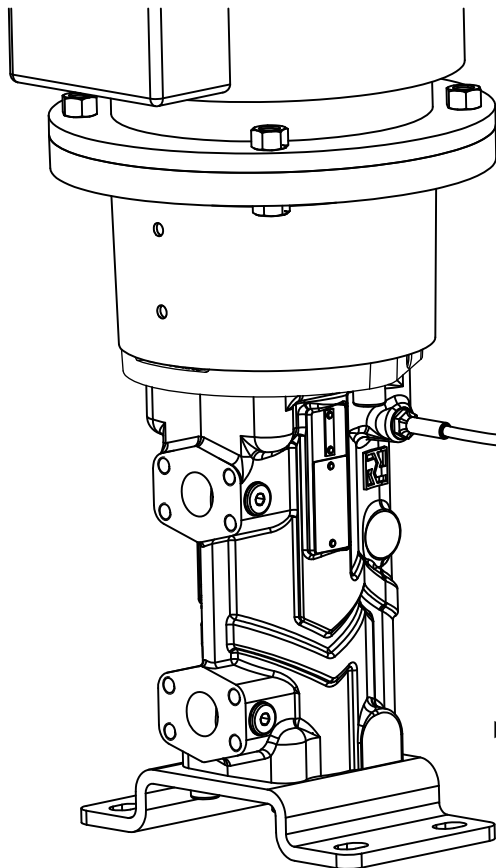

Subject to technical alteration!



ALLWEILER GmbH
Postfach 1140 · 78301 Radolfzell
Allweilerstr. 1 · 78315 Radolfzell
Germany
Tel. +49 (0)7732-86-0
Fax +49 (0)7732-86-436
E-mail: service@allweiler.de
Internet: <http://www.allweiler.com>
GB/2019.02 – Ident-No. 488130