

CONTOIL[®] **DN 4 - 8**

Measurement

CONTOIL®

Fuel oil meters DN 4 - 8 (12)

Fuel consumption measurement for trucks, buses, trains, construction and agricultural machinery, small boats and generators as well as for burners.

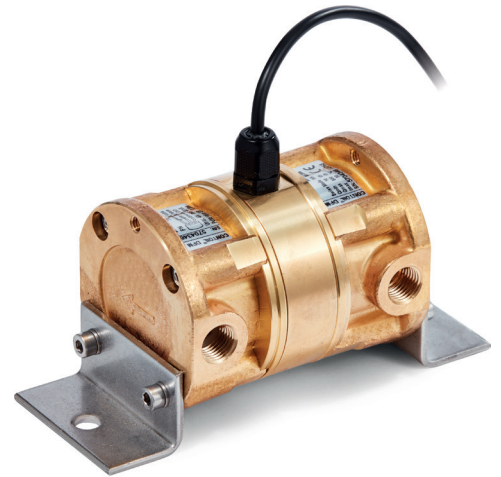

Features:

- » Supports most used models of vehicles
- » Proved and tested system
- » Easy and accurate reading of engine fuel consumption
- » No extra maintenance necessary
- » Tamper-proof measurement

Benefits:

- » Low installation costs
- » Quick and easy installation
- » Short down-time of vehicle
- » Quick pay-back period



CONTENT

Introduction	4
Operating principle	5
Product range	6
Technical specifications	8
Project planning notes	22
Installation	24
Warranty, safety instructions	27



INTRODUCTION

Thank you for your decision to work with Aquametro Oil & Marine Fuel Measurement Products. This technical specification describes the installation, commissioning and use of CONTOIL® fuel oil meters. For additional information please contact your local sales agent at: www.aquametro-oil-marine.com.

Liability Disclaimer

The manufacturer cannot monitor the compliance to this manual as well as the conditions and methods during the installation, operation, usage and maintenance of the system regulator. Improper installation can cause damage and endanger people. Therefore, we assume no responsibility and liability for losses, damage or costs that result due to incorrect installation, improper operation, usage and maintenance or in any manner associated therewith. Similarly, we assume no responsibility for patent right or other right infringements of third parties caused by usage of this system regulator. The manufacturer reserves the right, without prior notification, to make modifications concerning the product, technical data or installation and operating manual.

Safety precautions

CONTOIL® fuel oil meters must only be used for their intended purpose and comply with local and international safety regulations. All documentation is to be followed exactly. None of the information stated here or elsewhere releases planners, installers and operators from their own careful and comprehensive assessment of the respective plant configuration in terms of functional capability and operational safety.

- » Local applicable working regulations must be complied with, during all work on the plant and/or ship.
- » All safety, installation and operation instructions as described in this manual must be followed.
- » Sensors are sensitive measuring instruments and should be treated carefully.



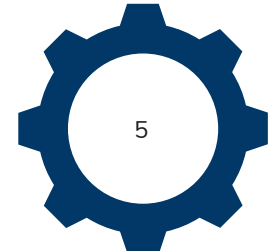

OPERATING PRINCIPLE

Function

CONTOIL® fuel oil meters work on the volumetric principle of rotary piston meters (positive displacement meters). The main features of this measuring principle are large measuring ranges, high accuracy, suitability for high viscosities and independence from power supply; flow disturbances do not influence proper operation.

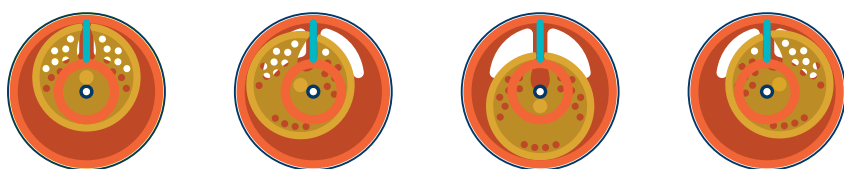

Leading manufacturers of oil burners and operators of heating systems, ships or diesel engines rely on CONTOIL® fuel oil meters - and with good reasons.

Advantages:

- » Optimal solution for every application
- » Can be mounted on the pressure or suction side of a pump
- » Space-saving installation, because no straight inlet / outlet sections are required
- » Flexible mounting of the meter in horizontal, vertical or inclined positions
- » Accurate measurement result, since the reading is independent of the temperature and viscosity of the fluid
- » Minimum failure costs due to simple function monitoring, rapid fault analysis and the possibility of simple repairs on site

Areas of application:

- » To measure fuel consumption of oil burners (e. g. in heating boilers, industrial furnaces, tar processing plants)
- » Consumption monitoring and optimization (ships, generators, etc)
- » Flow measurement for mineral oils
- » Optional remote processing and integration into superior systems
- » Manual dosing / filling / batch processing

Fuel types:

- » Fluids according to ISO 8217-2010
- » Heating fuel extra light / light

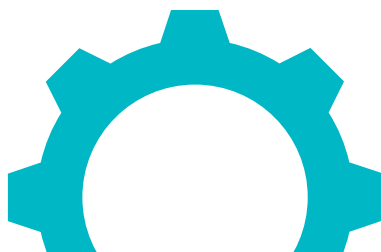

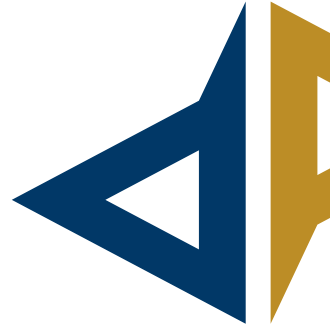

PRODUCT RANGE

CONTOIL® fuel oil meters DN 4 - 8 (12)

Fuel oil meters for direct fuel measurement

Hydraulic

VZO 4 Qmin / VZO 4 + 8 / VZO 4 + 8 OEM

Hydraulic connections 1/8" and M14x1.5

Main characteristics:

- » Optimal flow range 0.5 - 200 l/h
- » Temperature ranges -30 to +80 °C
- » Nominal pressure PN 25

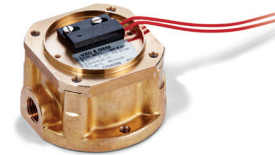

Electronic read out

VZO 4 + 8 RE / VZO 4 + 8 OEM

- » Pulse output signal: RE and VZO OEM

For more information, see page 8

Hydraulic

VZD2 4, 8 + 8E / VZP 4 + 8

Hydraulic connections 1/8" and M14x1.5

Main characteristics:

- » Optimal flow range 1 - 600 l/h
- » Temperature ranges -30 to +80 °C
- » Nominal pressure PN 25



Electronic read out

VZD2 / VZP 4 + 8

- » Electronic display: VZD2
- » Serial bus connection RS485: VZD2
- » Pulse output signal: VZD2 / VZP

For more information, see page 12

Fuel oil meters for differential fuel measurement

Hydraulic

DFM 8 ECO / DFM 12 ECO

Hydraulic connections M14x1.5

Main characteristics:

- » Optimal flow range 10 - 600 l/h
- » Temperature ranges -30 to +80 °C
- » Nominal pressure PN 16 bar

Electronic read out

DFM 8 ECO / DFM 12 ECO

- » Pulse output signal

[For more information, see page 16](#)



TECHNICAL SPECIFICATIONS

Technical data CONTOIL® VZO 4 Hydraulic



Hydraulic			VZO 4	VZO 4 Qmin	VZO 4 OEM
Nominal diameter	DN	mm	4	4	4
		inch	1/8	1/8	1/8
Hydraulic connection	G ¹⁾	inch	1/8	1/8	1/8
Nominal pressure	PN	bar	25	25	25
Max. medium temperature	T _{max}	°C	-30 to +80	-30 to +80	-30 to +80
Max. environmental temperature		°C	-10 to + 60	-10 to + 60	-10 to + 60
Max. storage temperature		°C	-40 to +85	-40 to +85	-40 to +85
Protection class	IP		50	50	65
Maximum flow rate	Q _{max}	l/h	80	40	80
Continuous flow rate	Q_{cont}	l/h	50	25	50
Minimum flow rate	Q _{min}	l/h	1	0.5	1
Approx. starting flow rate		l/h	0.4	0.3	0.4
Max. permissible error of actual value			<±1.0 % ²⁾	<±1.0 % ²⁾	<±1.0 % ²⁾
Repeatability			<±0.2 %	<±0.2 %	<±0.2 %
Measuring chamber volume		cm ³	5	5	5
Fuel			diesel and low viscosity fuels		
Max. viscosity		cSt	6	6	6
Safety filter mesh size		mm	0.125	0.125	-
Weight		kg	0.65	0.65	0.65
Housing finish			brass gold color		

1) G-threads have a parallel shape in accordance with the DIN-EN-ISO 228-1 standard with flank angle 55°.

2) 0.5 - 1 l/h ±5 %; 1 - 2 l/h ±2.5 %

Technical data

CONTOIL® VZO 8

Hydraulic



Hydraulic		VZO 8		VZO 8 OEM
Nominal diameter	DN	mm	8	8
		inch	1/4	1/4
Hydraulic connection			G ¹⁾ 1/4 inch	M14x1.5 mm
Nominal pressure	PN	bar	25	25
Max. medium temperature	T _{max}	°C	-30 to +80	-30 to +80
Max. environmental temperature		°C	-10 to +60	-10 to +60
Max. storage temperature		°C	-40 to +85	-40 to +85
Protection class	IP		50	65
Maximum flow rate	Q _{max}	l/h	200	200
Continuous flow rate	Q_{cont}	l/h	140	140
Minimum flow rate	Q _{min}	l/h	4	4
Approx. starting flow rate		l/h	1.6	1.6
Max. permissible error of actual value			<±1.0 ²⁾	<±1.0 % ²⁾
Repeatability			<±0.2 %	<±0.2 %
Measuring chamber volume		cm ³	12.44	12.44
Fuel			diesel and low viscosity fuels	
Max. viscosity		cSt	6	6
Safety filter mesh size		mm	0.15	0.15
Weight		kg	0.75	0.75
Housing finish			brass gold color	

1) G-threads have a parallel shape in accordance with the DIN-EN-ISO 228-1 standard with flank angle 55°.

2) 4 - 5 l/h ±2 %



Technical data

CONTOIL® VZO 4 + 8

Electrical and output specifications

Electronic			VZO 4	VZO 8	VZO 4 OEM	VZO 8 OEM
Reed pulser						
RE 1		I/pulse	-	◀▶	-	-
RE 0.1		I/pulse	◀▶	-	-	-
RE 0.00125		I/pulse	◀▶	-	-	-
RE 0.00311		I/pulse	-	◀▶	-	-
Pulse frequency						
RE 0.00125	at Q _{max}	Hz	17.777	-	-	-
	at Q _{min}	Hz	0.222	-	-	-
RE 0.00311	at Q _{max}	Hz	-	17.864	-	-
	at Q _{min}	Hz	-	0.357	-	-
Reed pulser RE		I/pulse			0.005	0.01244
Pulse frequency RE	at Q _{max}	Hz			4.444	4.444
	at Q _{min}	Hz			0.056	0.089

Electronic	REED pulser	
CONTOIL® VZO 4 + 8		
Switching element	Reed switch with dry contact (inert gas)	
Switching voltage	Max. 48 VAC/DC, protection class III (SELV)	
Switching current	Max. 50 mA	
Quiescent current	Open contact	
Switching power	Max. 2 W	
ON-time	VZO 4-RE 0.00125:	30 - 70 % (17 - 39 ms at 80 l/h)
	VZO 4-RE 0.1:	40 - 60 %
	VZO 8-RE 0.00311:	30 - 70 % (17 - 39 ms at 200 l/h)
	VZO 8-RE 1:	40 - 60 %
Protection class	IP 50 (IEC 60529) against harmful dust deposits Option: IP 54 additional against splashing water	
Connections	Plug on connector with cable 3.5 - 5 mm Ø	

Electronic CONTOIL® VZO 4 + 8 OEM	REED pulser
Switching element	Reed switch with dry contact (inert gas)
Switching voltage	Max. 230 VAC/DC
Switching current	Max. 50 mA
Quiescent current	Open contact
Switching power	Max. 3 VA
ON-time	40 - 55 %
Protection class	IP 65 (IEC 60529) against dust and water jets
Connections	Cable cross section 2 x 0.5 mm ² , length 480 mm

Safety note

When connecting the Reed pulser to a low-voltage power source (50 - 250 VAC/DC), the specialist installing the equipment is responsible for ensuring that all local regulations are observed (e. g. regulations for electrical installations, personnel safety).

Avoid disturbance of electromagnetic fields.



Technical data

CONTOIL® VZD2 4 / VZP 4

Hydraulic



Hydraulic		VZD2 4	VZP 4
Nominal diameter	DN	mm	4
		inch	1/8
Hydraulic connection	G ²⁾	inch	1/8 (14x1.5) ¹⁾
Nominal pressure	PN	bar	25
Max. medium temperature	T _{max}	°C	-30 to +80
Max. environmental temperature ³⁾		°C	-20 to +60
Max. storage temperature		°C	-40 to +85
Protection class	IP		66
Maximum flow rate	Q _{max}	l/h	80 ⁴⁾
Continuous flow rate	Q_{cont}	l/h	50
Minimum flow rate	Q _{min}	l/h	1
Approx. starting flow rate		l/h	0.4
Max. permissible error of actual value			<±1.0 % ⁵⁾
Repeatability			<±0.2 %
Measuring chamber volume		cm ³	5
Fuel			diesel and low viscosity fuels
Max. viscosity		cSt	6
Safety filter mesh size		mm	0.125
Weight		kg	0.65
Housing finish			brass gold color

1) Connection with adapter set VSR, part no.: 80630

2) G-threads have a parallel shape in accordance with the DIN-EN-ISO 228-1 standard with flank angle 55°.

3) If the device is used below or above stated temperature rating, the LCD can react slower and life time can be shortened.

4) Do not use for meter sizing.

5) 1- 2 l/h ±2.5 %

Technical data

CONTOIL® VZD2 8 + 8E / VZP 8

Hydraulic

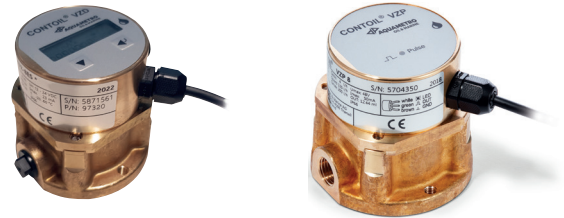

Hydraulic			VZD2 8	VZD2 8E	VZP 8
Nominal diameter	DN	mm	8	8	8
		inch	1/4	1/4	1/4
Hydraulic connection		mm	M14x1.5	M14x1.5	M14x1.5
Nominal pressure	PN	bar	25	25	25
Max. medium temperature	T _{max}	°C	-30 to +80	-30 to +80	-30 to +80
Max. environmental temperature ¹⁾		°C	-20 to +60	-20 to +60	-20 to +60
Max. storage temperature		°C	-25 to +80	-25 to +80	-25 to +80
Protection class	IP		66	66	66
Maximum flow rate	Q _{max}	l/h	200 ²⁾	600 ²⁾	200 ²⁾
Continuous flow rate	Q_{cont}	l/h	140	400	140
Minimum flow rate	Q _{min}	l/h	4	10	4
Approx. starting flow rate		l/h	1.6	2	1.6
Max. permissible error of actual value			<±1.0 % ³⁾	<±1.0 %	<±1.0 % ³⁾
Repeatability			<±0.2 %	<±0.2 %	<±0.2 %
Measuring chamber volume		cm ³	12.44	12.44	12.44
Fuel			diesel and low viscosity fuels		
Max. viscosity		cSt	6	6	6
Safety filter mesh size		mm	0.15	0.15	0.15
Weight		kg	0.75	0.75	0.65
Housing finish			brass gold color		

1) If the device is used below or above stated temperature rating, the LCD can react slower and life time can be shortened.

2) Do not use for meter sizing.

3) 4 - 5 l/h ±2 %

Technical data

CONTOIL® VZD2 4, 8 + 8E / VZP 4 + 8

Electrical and output specifications

Electronic		VZD2 4, 8 + 8E	
Environment			
Maximum environment temperature	Tmax	°C	-20 to +60
Maximum storage temperature	Tmax	°C	-25 to +80
Maximum storage humidity, none condensing	Hmax	%h	95
Protection class	IEC60529		IP66
Safety, vibration and shock	IEC68		IEC68
Power supply			
Voltage range	U	VDC	12 - 24
Maximum power consumption	P	W	0.4
Update interval		s	1
Data preservation			EEPROM
Relay output			
Switching element		Ω	solid state relay
Resistance ON		MΩ	≤40
Resistance OFF		VDC	≥10
Max. supply voltage		mA	≤48
Max. switching current		ms	≤50
Pulse width		Hz	2 - 500 (dynamic)
Pulse frequency			0 - 200
Serial interface			
Isolation			galvanically
Typical output capacitance:		pF	100
Type			RS485 2-wire
Protocol			Modbus M-Bus
Max. speed Modbus		kBaud	38.4
Max. speed M-Bus		kBaud	9.6

Electronic		VZP 4	VZP 8
Pulse value (HI-Res)	I/pulse	0.005	0.01244
Pulse value (Param)	I/pulse	-	-
Pulse width (HI-Res)	ms	20	20
Pulse width (Param)	ms	-	-
Current load (open drain output) max.	mA	50	50
Output operational voltage max.	VDC	48	48
Output dropout voltage		max. 2 VDC at 50 mA	
Power supply	VDC	12 - 24	12 - 24
Amplitude range		equal to power supply	

Functional diagram CONTOIL® VZD2 / VZP electrical and output specification

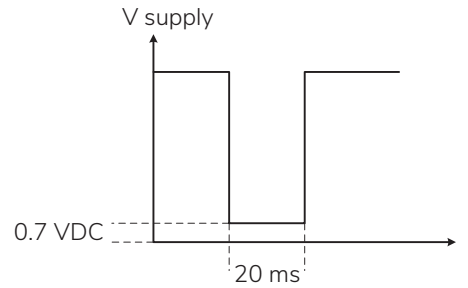
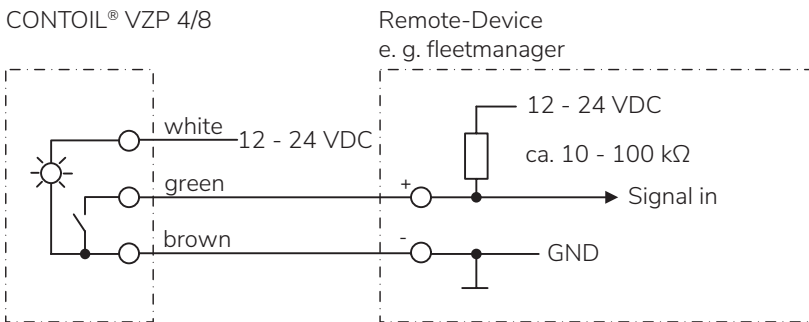
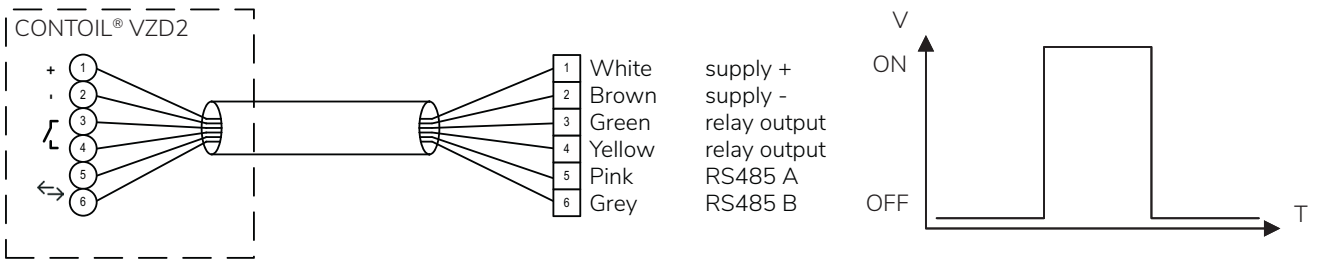

Display view

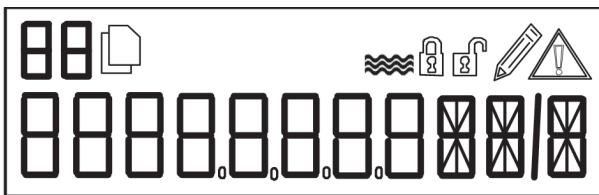



Technical data

CONTOIL® DFM 8 + 12 ECO

Hydraulic



Hydraulic			DFM 8 ECO	DFM 12 ECO
Nominal diameter	DN	mm	8	12
		inch	1/4	1/4
Hydraulic connection		mm	M14x1.5	M14x1.5
Nominal pressure	PN	bar	16	16
Max. medium temperature	T _{max}	°C	-30 to +80	-30 to +80
Max. environmental temperature		°C	-20 to +80	-20 to +80
Max. storage temperature		°C	-40 to +85	-40 to +85
Protection class	IP		66	66
Maximum flow rate	Q _{max}	l/h	260	600
Continuous flow rate	Q_{cont}	l/h	200	400
Minimum flow rate	Q _{min}	l/h	10	10
Approx. starting flow rate		l/h	0.4	0.4
Max. permissible error of actual value			<±1.0 %	<±1.0 %
Repeatability			<±0.2 %	<±0.2 %
Measuring chamber volume		cm ³	12.44	12.44
Fuel			diesel and low viscosity fuels	
Max. viscosity		cSt	6	6
Safety filter mesh size		mm	0.15	0.15
Weight		kg	0.65	0.65
Housing finish			brass gold color	

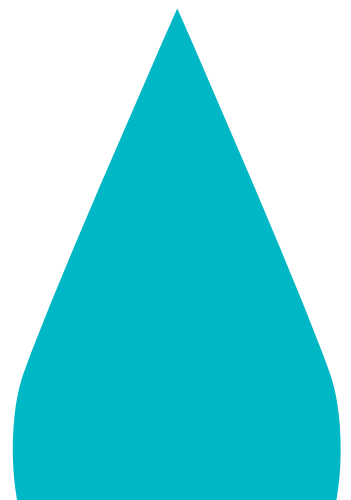



Technical data

CONTOIL® DFM 8 + 12 ECO

Electrical and output specifications

Electronic		DFM 8 ECO	DFM 12 ECO
Pulse value	l/pulse	0.01244	0.01244
Frequency at Q _{cont}	Hz max	<4.5	<9
Pulse width	ms	20	20
Current load (open drain output) max.	mA	50	50
Power supply	VDC	12 - 24	12 - 24
Amplitude range		equal to power supply	

Functional diagram passive output

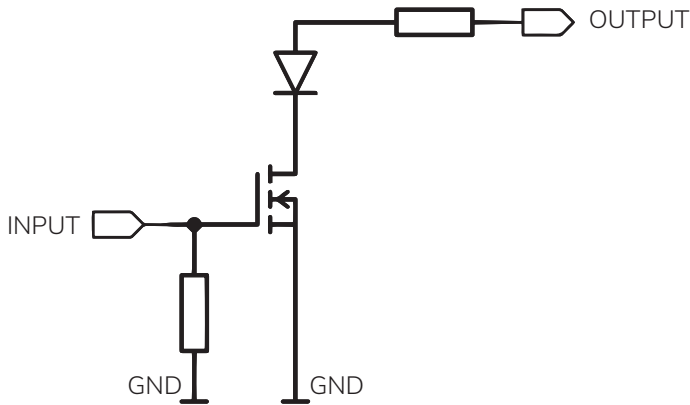

Output signal specification

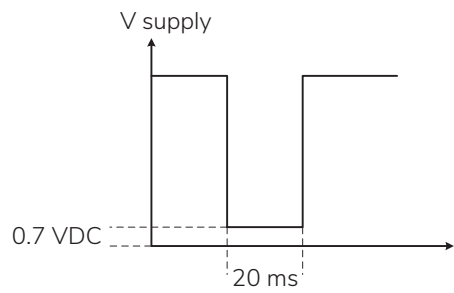

Functional diagram: pulse specification; passive pulse

Whenever a pulse is generated, the electronic switch will be closed and the incoming 12 - 24 VDC will be redirected to the external device.

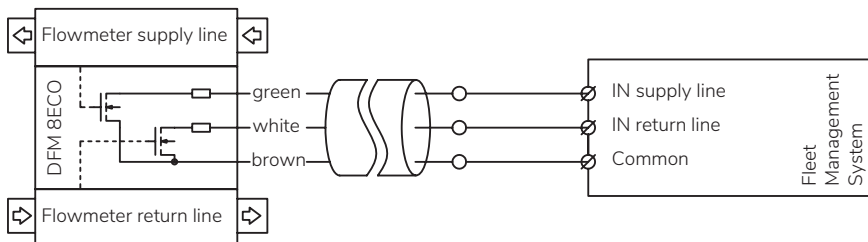

Dimensional drawings (all dimensions in mm)

CONTOIL® VZO 4 + 8

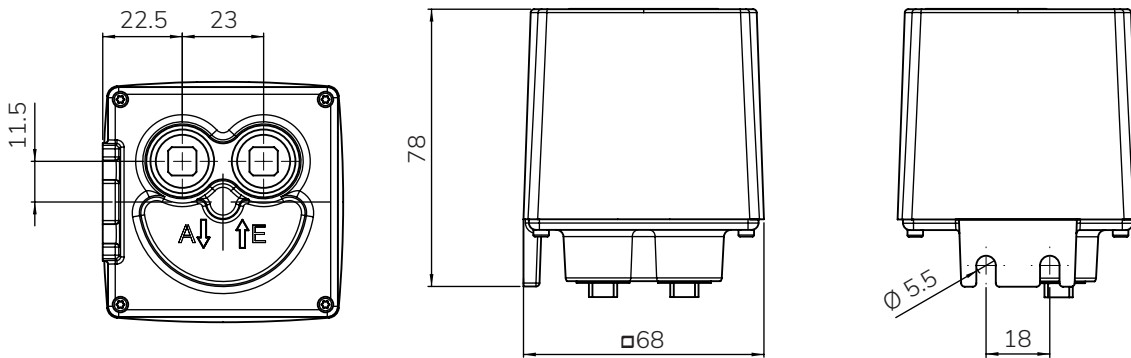

CONTOIL® VZO 4 + 8 RE

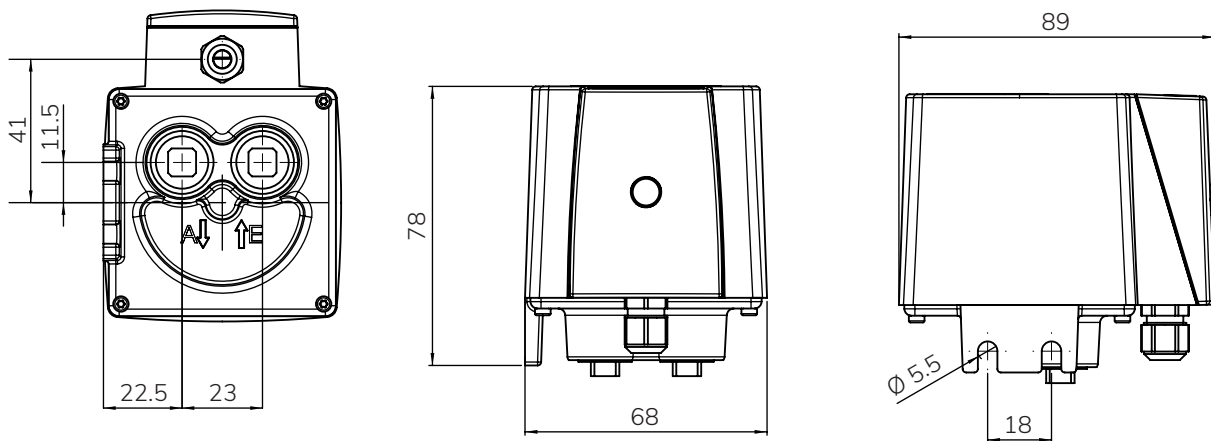

CONTOIL® VZO 4 OEM

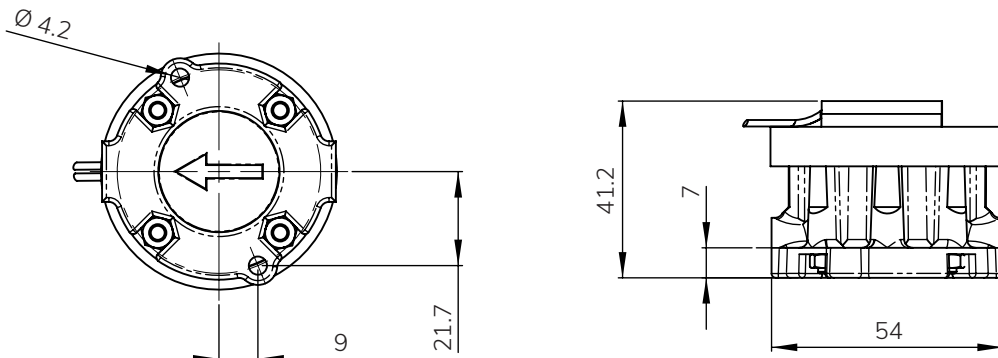

CONTOIL® VZO 8 OEM

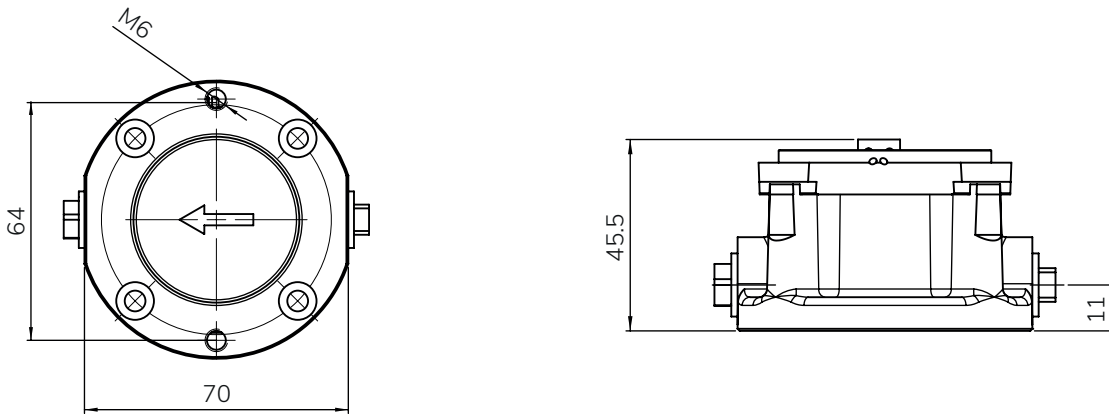

CONTOIL® VZD2 4 / VZP 4

G¹/₈" thread; with VSR mounting kit (G¹/₈" to M14x1.5)

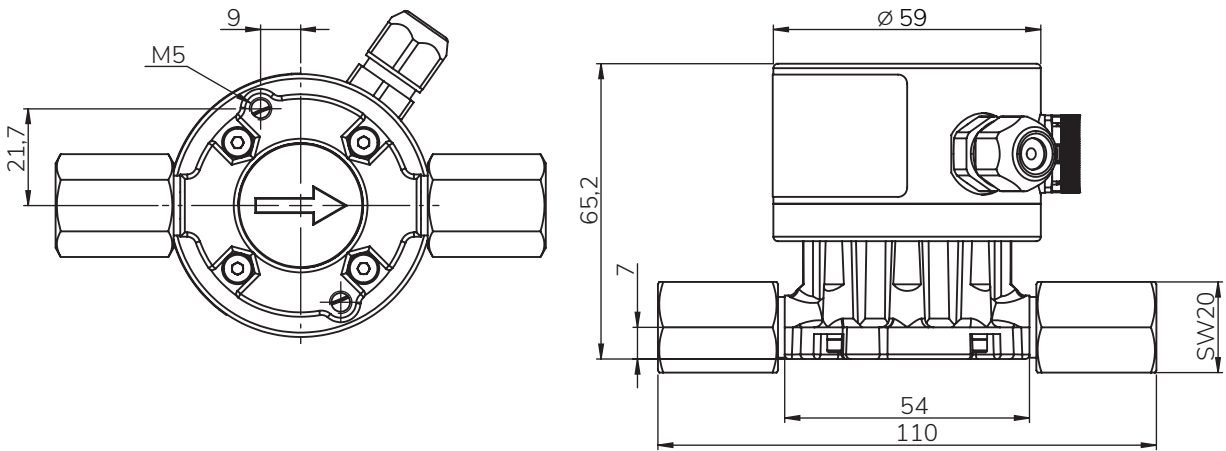

CONTOIL® VZD2 8 + 8E / VZP 8

M14x1.5 thread

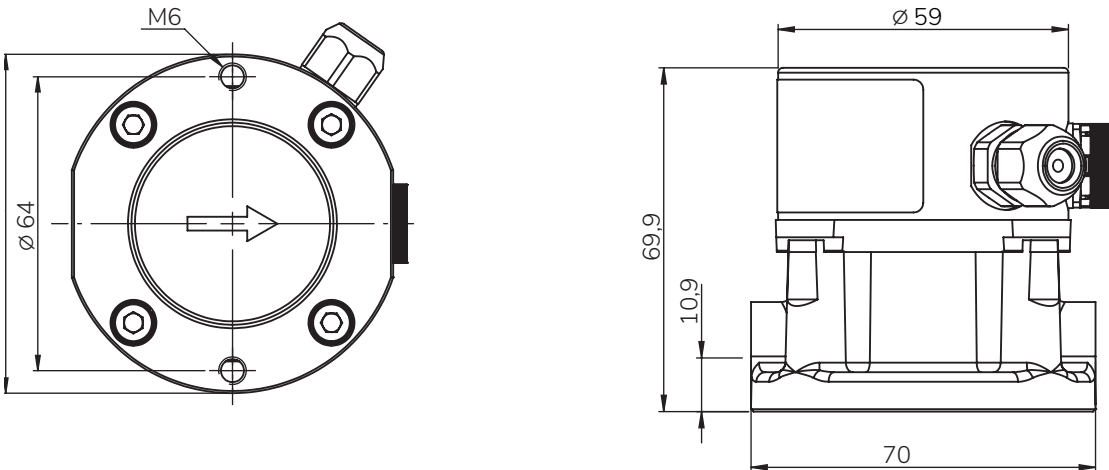

CONTOIL® DFM 8 ECO / DFM 12 ECO

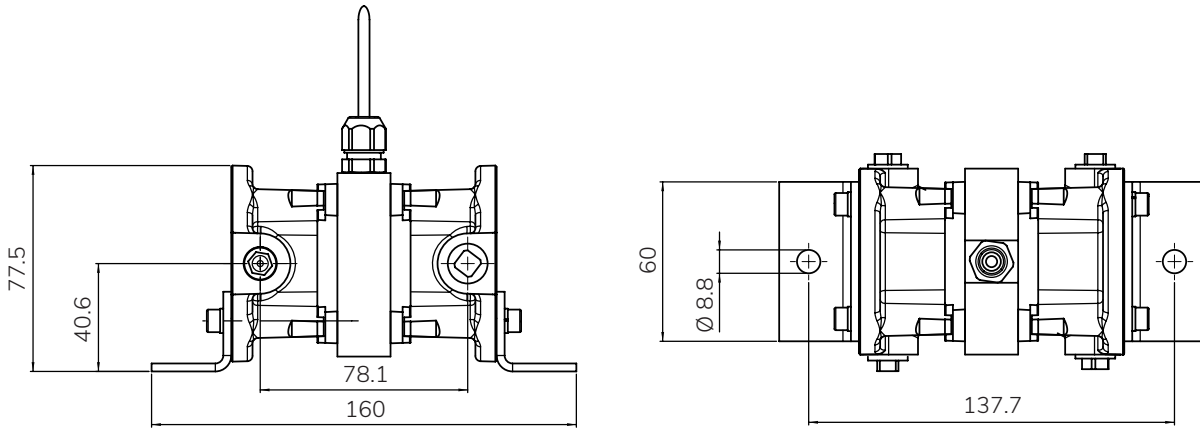

Pressure drop curves

CONTOIL® VZD2 4 / VZP 4, VZO 4 Q_{min}, VZO 4, VZO 4 OEM

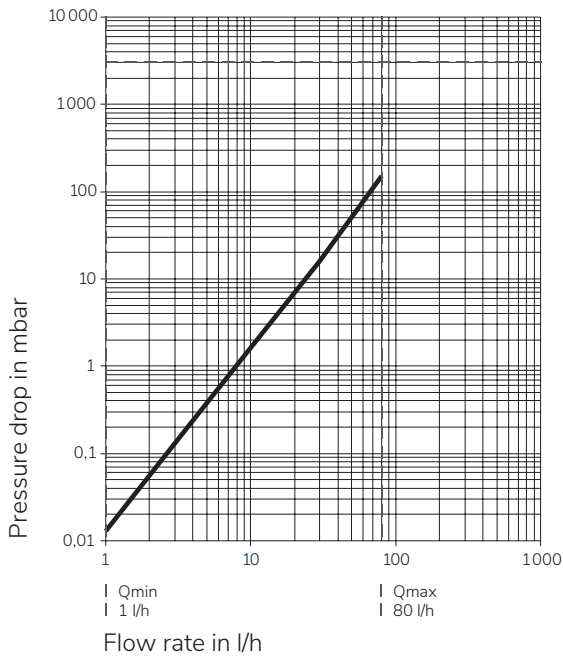

CONTOIL® VZD2 8 + 8E / VZP 8, VZO 8, VZO 8 OEM, DFM 8 ECO, DFM 12 ECO

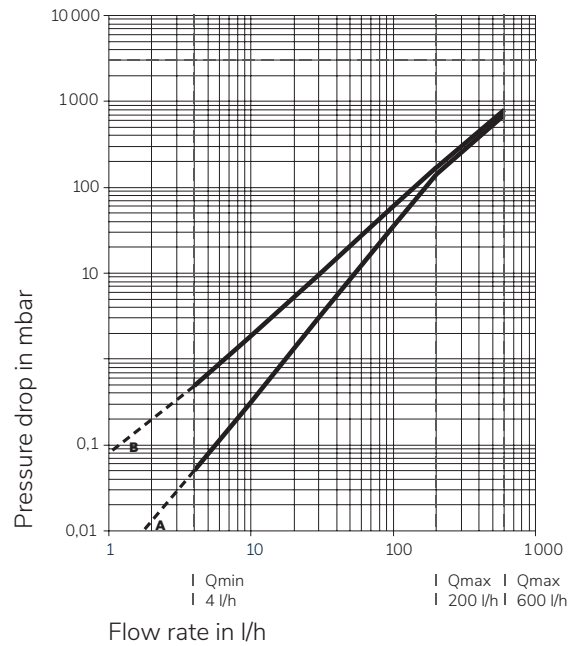





Viscosity diagrams:

- A = 5 mPas
- B = 50 mPas

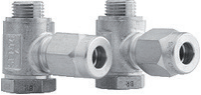
For a pressure drop of more than 1 bar, it is recommended to use the next larger meter size.

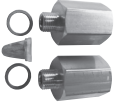
Accessories

VZO 4 + 8	Description	Art. No.
	Threaded connections kit PS-Kit VZO 4 1/8" - 8	81583
	Mounting kit PS-Kit VZO 8	81130
	Mounting kit ¹⁾ VSR-SET VZD2 4 / VZP 4 1/8" to M14x1.5	80630
	Threaded connections to suit PS-Kit VZO 8 VSR 3/8"	81156

1) 2 sets needed for one flow meter.

DFM	Description	Art. No.
	Hose connector ¹⁾ include 1 hollow union, 1 single banjo body, 2 copper seals DFM 8 ECO, DFM 12 ECO	80447

1) 4 sets needed for one DFM 8 ECO, DFM 12 ECO.

Mounting kit for VZO 8 - dimensions and some possible mounting positions

(all dimensions in mm)

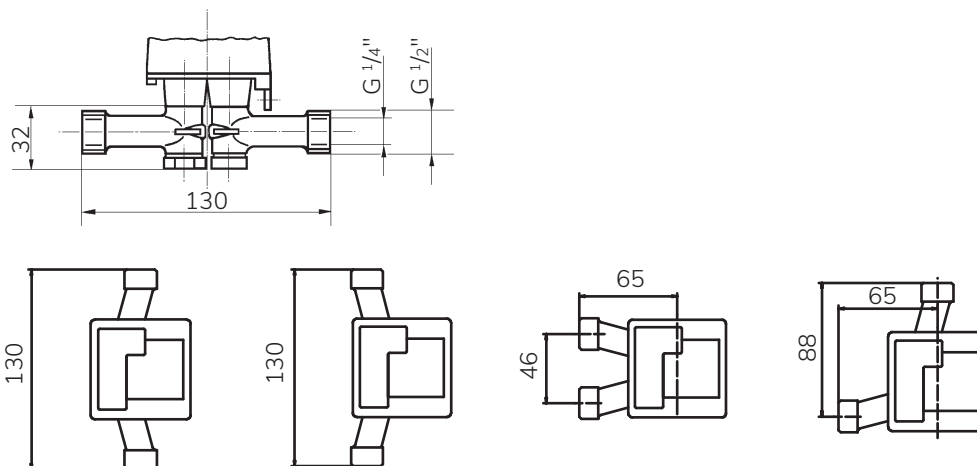

PROJECT PLANNING NOTES

Project Application - Burner

Mounting on pressure side of pump

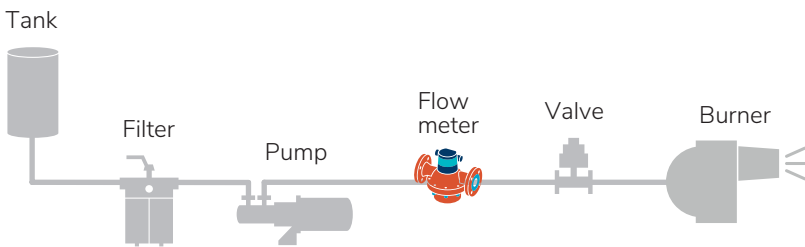

Mounting on suction side of pump

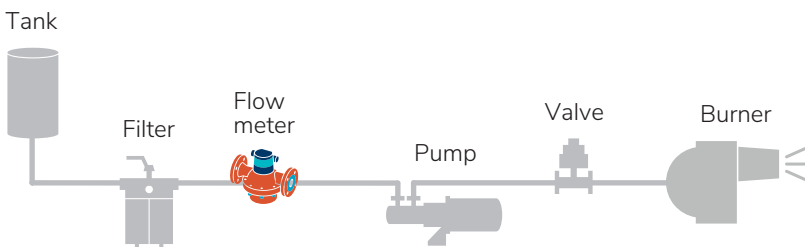

Indicative values on power for burners

Burner		Flow meter		
Power	Flow rate heating fuel		Flow rate Q _{min} - Q _{cont}	Nominal diameter
up to kW	kg/h	l/h	l/h	DN
500	42	50	1 - 50	4
1300	113	135	4 - 140	8
4000	336	400	10 - 400	12

Formula for consumption in litres/hour:

$$\frac{\text{Burner power in kW}}{\text{Energy value of fuel in kWh/kg} \times \text{density in kg/dm}^3}$$

Example:

$$\frac{4000 \text{ kW}}{11.8 \text{ kWh/kg} \times 0.84 \text{ kg/dm}^3} = 4000 : 9.912 = 403 \text{ l/h}$$

Project Application - Engine

Direct measurement

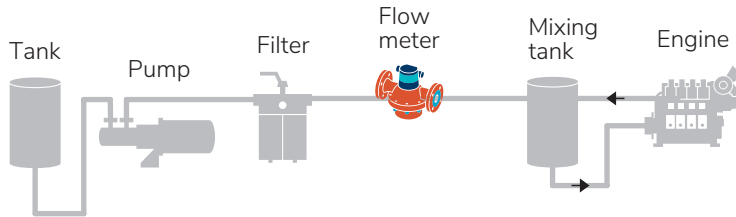

Differential measurement

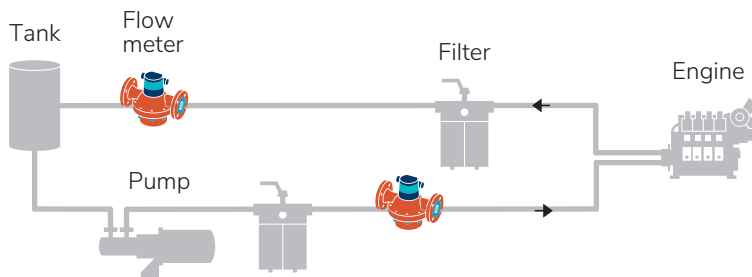

Indicative values on power for engines

Engine		Flow meter ¹⁾		
Power	Diesel fuel consumption		Flow rate	Nominal diameter
			$Q_{min} - Q_{cont}$	
up to HP	up to kW	l/h	l/h	DN
250	184	50	1 - 50	4
680	500	135	4 - 140	8
2000	1470	400	10 - 400	12

1) For differential measurement the flow meter has to be selected according to the pump flow rate in supply and the flow in the return pipe.

Formula: $1 \text{ DIN-HP} = 0.736 \text{ kW}$ $1 \text{ kg Diesel at } 0.84 \text{ kg/dm}^3 = 1.19 \text{ l}$
 $1 \text{ kW} = 1.36 \text{ DIN-HP}$

Rule of thumb: approx. 190 g Diesel/kWh correspond to 0.226 l Diesel/kWh
 approx. 140 g Diesel/HP correspond to 0.167 l Diesel/HP

INSTALLATION

Planning

Flow meters are precision measuring instruments. They achieve optimal results if

- » a few important rules are observed during plant design,
- » mounting and commissioning are carried out with care,
- » the meters are used for their defined purpose only.

Layout of pipework

- » The quantities consumed by all consumers must be registered by the meter.
- » Rotary piston meters do not require flow conditioners or inlet runs (after bends, T-pieces or fittings). They may be mounted in horizontal, vertical or inclined position, except with the head pointing downwards.
- » The layout of piping must ensure that the meter is at all times filled with liquid and that no inclusions of air or gas may occur. Do not install the instrument at the highest point of the installation.
- » Meter and accessory equipment must be easily accessible.

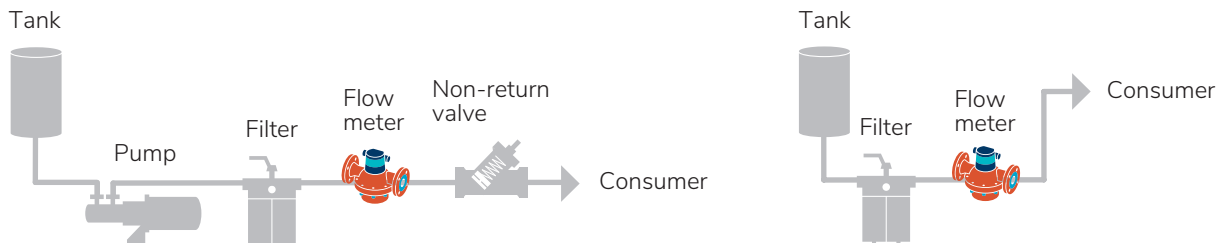

Selection of the meter and ancillaries

To be considered when selecting the meter:

- » Operating temperature
- » Viscosity of the medium
- » Operating pressure
- » Flow rate
- » Resistance of the material against fuel to be metered and working conditions

The technical data are valid for the following reference conditions: EL heating fuel/diesel at 20 °C. For higher viscosities or if the meter is mounted on the suction side of a pump, it is necessary to determine the pressure drop and the flow rate that can still be attained by using the pressure loss curves. If the pressure drop is more than 1 bar, it is advised to use the next larger meter size.

Dirt filter, safety filter

Filters are any way required in the system to protect engines and pumps to keep their performance and live time. For fuel oil meters this is no different - that's why we recommend installing the fuel oil meters (in flow direction) always directly after the filter. Some particles in the fuel are also from engine's wear and tear, that's why we also recommend a filter in the fuel return line. Usually basket type filters are best choice for the return line and automatic filters in the supply line. Major engine producers recommend a mesh size of 5 - 10 μm (automatic filters), especially to filter out very abrasive cut fines. It is best for the flow meter to install it between this automatic filter and the engine. The maximum filter mesh size for a respective meter can be found in below table.

Examples of filter:

Maximum mesh width for filters

Nominal diameter

DN 4	0.08 mm
DN 8	0.1 mm

- » The filter mounted in the meter inlet is only a safety filter and is too small to act as a dirt filter.
- » If a dirt filter with the given mesh size is used, the safety filter in the meter inlet may be removed.

Stop valves or non-return valves

In order to avoid backflow and draining, stop valves have to be mounted after the meter. Backflow and draining cause measuring errors and can damage the meter.

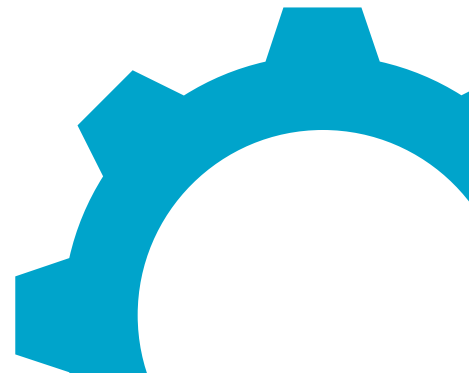
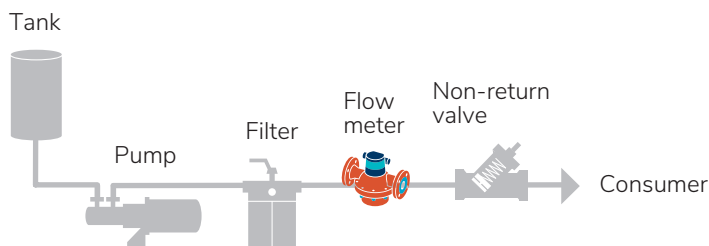

Filling / Dosing

For filling and dosing the valve has to be mounted between meter and outlet. The shorter the pipe section between meter and outlet, the higher the accuracy. Fast opening and shutting of the valve should be avoided (pressure hammer!).

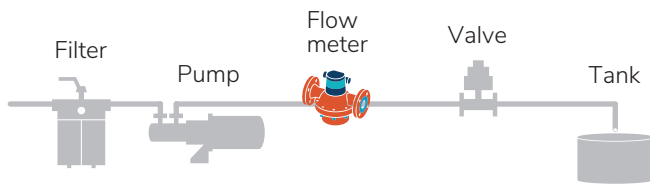

Remote Processing / Ancillaries

Any backflow must be avoided on meters equipped with pulser for remote processing. If this cannot be achieved by appropriate plant design, a non-return valve should be fitted.

Electrical wiring and installations

Electrical wiring and installations are subject to statutory regulations which must be taken into account when planning the system. For installations in zones subject to explosion hazards, consult an appropriate expert.

The following factors should be taken into account during plant design:

- » ancillaries connected to the meter
- » environmental interference
- » maximum permissible cable lengths (with or without amplifier)
- » junction boxes, cable guides



WARRANTY, SAFETY INSTRUCTIONS

Warranty Disclaimer

Aquametro Oil & Marine guarantees the quality of the product in the context of its General Terms of Business. The owner, operator or installer will be liable for the correct installation as well as the appropriate handling of the equipment upon its receipt.

- » Please observe the application, mounting and operating instructions.
- » Use the unit exclusively for its designed purpose.
- » Maintain the unit and service it according to prescriptions.
- » Use accessories only if their applicability is technically safe.

Safety rules and precautionary measures

The manufacturer accepts no responsibility if the following safety rules and precautions are disregarded.

- » Modifications of the device implemented without preceding written consent from the manufacturer, will result in the immediate termination of product liability and warranty period.
- » Installation, operation, maintenance and decommissioning of this device must be carried out by trained, qualified specialists, authorized by the manufacturer, operator or owner of the facility. The specialist must have read and understood these mounting and operating instructions and must follow the instructions here in.
- » Check the voltage and the information on the type plate before installing the device.
- » Check all connections, settings and technical specifications of peripherals which may be present.
- » Open the housing or parts of housings, which electric or electronic components included, only when the electric power is turned off.
- » Do not touch any electronic components (ESD sensitivity).
- » Expose the system with respect to the mechanical load (pressure, temperature, IP protection, etc.), only to a maximum of the specified classifications.
- » During operations that involve mechanical components of the system, release the pressure in the pipe system or reduce the temperature of the medium to a safe level for humans.
- » None of the information stated here or elsewhere releases planners, installers and operators from their own careful and comprehensive assessment of the respective system configuration in terms of functional capability and operational safety.
- » The local labour and safety laws and regulations must be observed.



info@aquametro-oil-marine.com
www.aquametro-oil-marine.com

Aquametro Oil & Marine AG
CH-4106 Therwil, Switzerland
Phone +41 61 725 44 00

Aquametro Oil & Marine GmbH
DE-18119 Rostock, Germany
Phone +49 381 382 530 00