



Units for regulation and
monitoring of pressure
and temperature
type RT

Units for regulation and monitoring of pressure and temperature, type RT

Pressure controls type RT

0	5	10	15	20	25	30 bar	Range p_0 bar	Type	Further information
<p style="text-align: center;"><i>Standard pressure controls</i></p>							-1 -0	RT 121	See contents page 3
							0 -0.3	RT 113	
							0.1 -1.1	RT 112	
							0.2 -3	RT 110	
							-0.8 -5	RT 1, 1A	
							0.2 -6	RT 200	
							1 -10	RT 116	
							4 -17	RT 5, 5A	
							10 -30	RT 117	
							<p style="text-align: center;"><i>Pressure controls for steam plant approved by Vd UVV</i></p>		
0 -2.5	RT 33B, RT 35 W								
1 -10	RT 30 AW/AB/AS								
1 -10	RT 116W								
2 -10	RT 31 W/B/S								
5 -25	RT 19 W/B/S								
<p style="text-align: center;"><i>Pressure controls with adjustable neutral zone</i></p>							-0.8 -5	RT 1AL	
							0.2 -3	RT 110L	
							0.2 -6	RT 200L	
							4 -17	RT 5AL	
							10 -30	RT 117L	
<p style="text-align: center;"><i>Differential pressure controls</i></p> <p>$\Delta p = 0-0,9$ bar</p> <p>$\Delta p = 0,1-1$ bar</p> <p>$\Delta p = 0,1-1,5$ bar</p> <p>$\Delta p = 0,5-4$ bar</p> <p>$\Delta p = 0,5-6$ bar</p> <p>$\Delta p = 1-6$ bar</p>							-1 -6	RT 266AL	
							-1 -6	RT 263AL	
							-1 -9	RT 262AL/A	
							-1 -18	RT 260AL/A	
							-1 -36	RT 260A	
							-1 -36	RT 265A	

Thermostats type RT

-50	0	50	100	150	200	250	300°C	Range °C	Type	Further information
<p style="text-align: center;"><i>Thermostats with cylindrical remote sensor</i></p>								-60- -25	RT 10	See contents page 15
								-45- -15	RT 9	
								-30- 0	RT 13	
								-25- 15	RT 3, 2, 7	
								-20- 12	RT 8	
								-5- 10	RT 12	
								-5- 30	RT 14	
								-5- 50	RT 26	
								5- 22	RT 23	
								8- 32	RT 15	
								25- 90	RT 101	
								20- 90	RT 106	
								30- 140	RT 108	
								70- 150	RT 107	
<p style="text-align: center;"><i>Thermostats with room sensors, duct sensor and capillary tube sensor</i></p>								-50- -15	RT 17	
								-30- 0	RT 11	
								-25- 15	RT 34	
								-5- 30	RT 4	
								10- 35	RT 115	
								10- 45	RT 103	
								15- 45	RT 140	
								40- 80	RT 141	
<p style="text-align: center;"><i>Thermostats with adjustable neutral zone</i></p>								-20- 12	RT 8L	
								-5- 30	RT 14L	
								0- 38	RT 16L	
								15- 45	RT 140L	
<p style="text-align: center;"><i>Differential thermostats</i></p>								25- 90	RT 101L	
								0- 15	RT 270	
<p style="text-align: center;"><i>Differential thermostats</i></p>								0- 20	RT 271	

Pressure controls, type RT

Contents

	Page		Page
Survey of types, pressure ranges	2	Function description	9
Introduction	3	Function description fail-safe,	10
Technical data and code nos., all types	4-5	Pressure control for liquid level control	10
Approvals	5	Pressure controls with adjustable neutral zone	11-12
Technical data and material in contact with medium	6	Differential pressure controls	13-14
Dimensions and weight	7	RT spare parts and accessories	28-31
Installation	8		

Introduction

Type RT pressure controls incorporate a pressure controlled, single-pole changeover switch where the contact position depends on the pressure in the connection port and the set value. The RT series consists of pressure controls, differential pressure controls and pressure controls for neutral zone regulation. These units are for general use within the industrial and marine sectors.

The RT series also covers safety pressure controls for steam boiler plant.

For installations in which operation is particularly critical from safety and economic points of view, the use of fail-safe pressure controls is recommended. The use of gold-plated contacts is also recommended in such installations, provided operation involves only a few switching cycles or low signal currents and voltages.

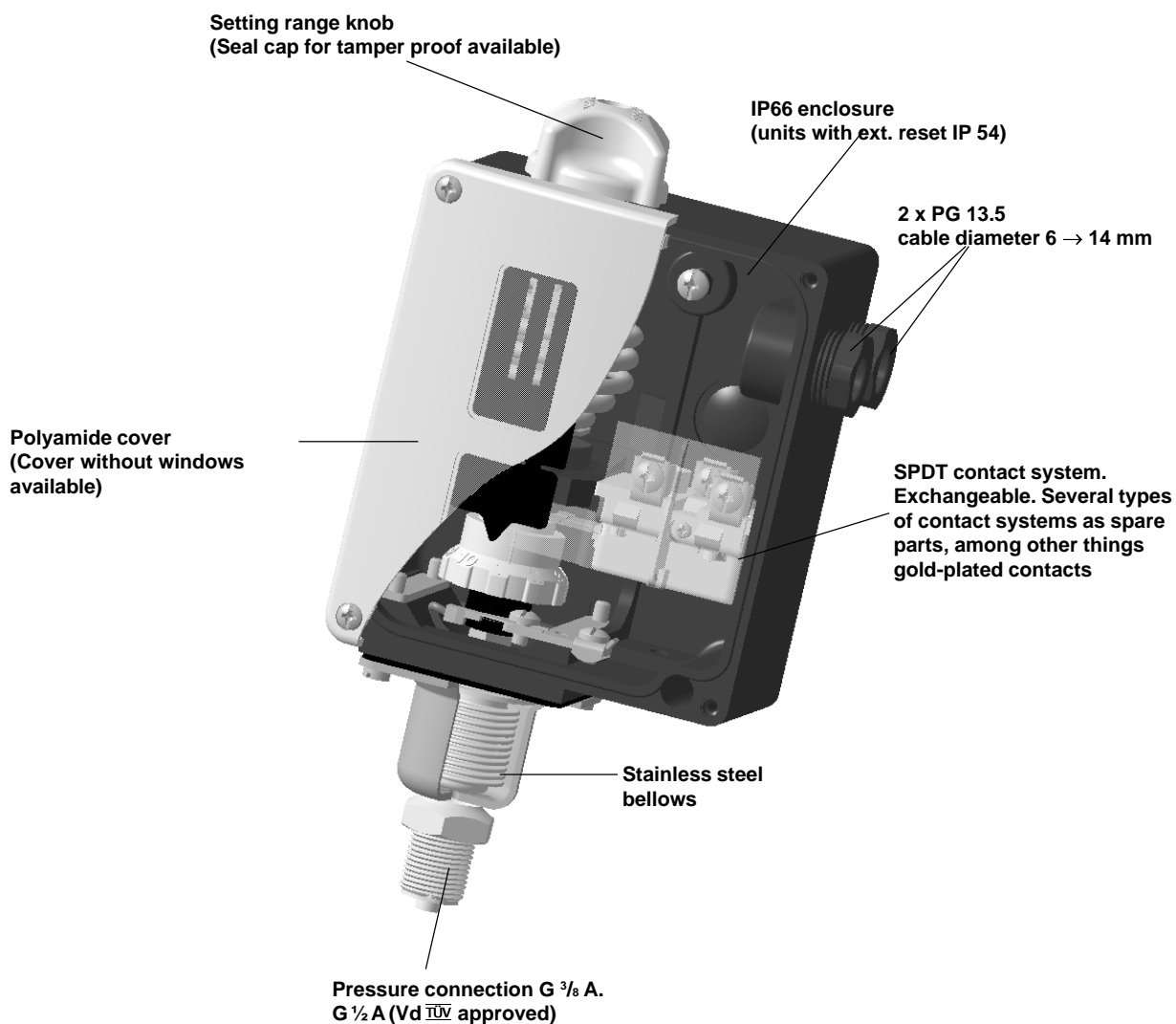

Pressure controls, type RT

Technical data and code nos.

When ordering, please state type and code number.

The type designation for the letters below means:
A: Unit suitable for the medium ammonia
L: Unit with neutral zone

Pressure controls Preferred versions



RT 113
for manual setting;
cover with windows



RT 116
for tamper proof;
cap and blank cover



RT 262 A
Differential pressure
control

Regulation range (p_e = effective pressure) bar	Adjustable/ fixed mechanical differential bar	Max. operating pressure PB bar	Max. test pressure p' bar	Pressure connection ISO 228/1	Code no.				Type
					 DANFOSS A17-686.12 SPDT	 DANFOSS A17-689.12 max. reset SPDT	 DANFOSS A17-692.12 min. reset SPDT	 DANFOSS A17-871.12 SPDT	
-1 -0	0.09 -0.4	7	8	G 3/8 A	017-5215				RT 121
0 -0.3	0.01 -0.05	0.4	0.5	G 3/8 A	017-5196				RT 113
0 -0.3	0.01 -0.05	0.4	0.5	G 3/8 A	017-5073³⁾				RT 113
0.1 -1.1	0.07 -0.16	7	8	G 3/8 A	017-5191			017-5193	RT 112
0.1 -1.1	0.07	7	8	G 3/8 A		017-5192			RT 112
0.2 -3	0.08 -0.25	7	8	G 3/8 A	017-5291			017-5292	RT 110
0.2 -3	0.08	7	8	G 3/8 A			017-5110		RT 110
-0.8 -5	0.5 -1.6	22	25	7/16-20 UNF	017-5245				RT 1
-0.8 -5	0.5	22	25	7/16-20 UNF			017-5246		RT 1
-0.8 -5	0.5 -1.6	22	25	G 3/8 A ¹⁾	017-5001				RT 1A
-0.8 -5	0.5	22	25	G 3/8 A ¹⁾			017-5002		RT 1A
-0.8 -5	1.3 -2.4	22	25	G 3/8 A ¹⁾	017-5007				RT 1A
0.2 -6	0.25 -1.2	22	25	G 3/8 A	017-5237			017-5240	RT 200
0.2 -6	0.25	22	25	G 3/8 A		017-5238	017-5239		RT 200
1 -10	0.3 -1.3	22	25	G 3/8 A	017-5203			017-5200	RT 116
1 -10	0.3	22	25	G 3/8 A		017-5204	017-5199		RT 116
4 -17	1.2 -4	22	28	G 3/8 A	017-5255			017-5253	RT 5
4 -17	1.2	22	28	G 3/8 A		017-5094²⁾			RT 5
4 -17	1.2 -4	22	28	G 3/8 A ¹⁾	017-5046³⁾				RT 5A
4 -17	1.2	22	28	G 3/8 A ¹⁾		017-5047³⁾			RT 5A
10 -30	1 -4	42	47	G 3/8 A	017-5295			017-5296	RT 117

¹⁾ Supplied with $\varnothing 6/\varnothing 10$ mm weld nipple. ²⁾ With seal cap. ³⁾ DNV approved with EPDM diaphragm.

Pressure controls with adjustable neutral zone

Regulation range (p_e) bar	Mechanical differential bar	Adjustable neutral zone bar	Max. operating pressure PB bar	Max. test pressure p' bar	Pressure connection	Code no.	Type
-0.8 -5	0.2	0.2 -0.9	22	25	G 3/8 A ¹⁾	017L0033	RT 1AL
0.2 -3	0.08	0.08 -0.2	7	8	G 3/8 A	017L0015	RT 110L
0.2 -6	0.25	0.25 -0.7	22	25	G 3/8 A	017L0032	RT 200L
4 -17	0.35	0.35 -1.4	22	25	G 3/8 A ¹⁾	017L0040	RT 5 AL
10 -30	1	1 -3.0	42	47	G 3/8 A	017L0042	RT 117L

¹⁾ Supplied with $\varnothing 6/\varnothing 10$ mm weld nipple.

Differential pressure controls

Regulation range Δp bar	Mechanical differential bar	Adjustable neutral zone bar	Operation range bar	Max. operating pressure PB bar	Max. test pressure p' bar	Pressure connection ISO 228/1	Code no.	Type
0 -0.9	0.05	0.05 -0.23	-1 -6	7	8	G 3/8 A ¹⁾	017D0081	RT 266AL
0.1 -1.0	0.05	0.05 -0.23	-1 -6	7	8	G 3/8 A ¹⁾	017D0045	RT 263AL
0.1 -1.5	0.1	0.1 -0.33	-1 -9	11	13	G 3/8 A ¹⁾	017D0043	RT 262AL
0.1 -1.5	0.1		-1 -9	11	13	G 3/8 A ¹⁾	017D0025	RT 262A
0 -0.3	0.035		-1 -10	11	13	G 3/8 A ¹⁾	017D0027²⁾	RT 262A
0.5 -4	0.3	0.3 -0.9	-1 -18	22	25	G 3/8 A ¹⁾	017D0048	RT 260AL
0.5 -4	0.3		-1 -18	22	25	G 3/8 A ¹⁾	017D0021	RT 260A
0.5 -6	0.5		-1 -36	42	47	G 3/8 A ¹⁾	017D0023	RT 260A
1.5 -11	0.5		-1 -31	42	47	G 3/8 A ¹⁾	017D0024	RT 260A
1 -6	0.5		-1 -36	42	47	G 3/8 A ¹⁾	017D0072³⁾	RT 265A

¹⁾ Supplied with $\varnothing 6/\varnothing 10$ mm weld nipple ²⁾ Non-snap action contacts (see spare parts and accessories, contact system 017-0181)

³⁾ With SPST and SPDT contact system for alarm and cut off funktion at 0.8 og 1 bar

Pressure controls, type RT

Technical data and code nos.

The designation letters mean:
 A: Units suitable for the medium ammonia.
 W: Units for control purposes.

B: Safety units with external reset

S: Safety units with internal reset

Pressure controls for steam plant, approved by Vd TÜV

Preferred versions

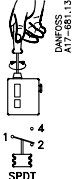
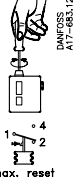
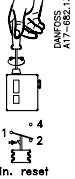
Regulation range (p_e -effective pressure)	Adjustable/ fixed mechanical differential	Max. operating pressure PB	Max. test pressure p'	Pressure connection	Code no.			Type
					 DANFOSS A17-681.13	 DANFOSS A17-681.12	 DANFOSS A17-681.13	
bar	bar	bar	bar					

For rising pressure, approved acc. to PED

0.1 –1.1	0.07	7	8	G ½A	017-5282		RT 112W
0 –2.5	0.1	7	8	G ½A	017-5280		RT 35W
1 –10	0.8	22	25	G ½A	017-5187		RT 30AW
1 –10	0.4	22	25	G ½A		017-5188	RT 30AB
1 –10	0.4	22	25	G ½A		017-5189	RT 30AS
5 –25	1.2	42	47	G ½A	017-5181		RT 19W
5 –25	1	42	47	G ½A		017-5182	RT 19B
5 –25	1	42	47	G ½A		017-5183	RT 19S

For falling pressure

0 –2.5	0.1	7	8	G ½A		017-5262	RT 33B
1 –10	0.2 –2	22	25	G ½A	017-5242		RT 116W
2 –10	0.3 –1	22	25	G ½A	017-5267		RT 31W
2 –10	0.3	22	25	G ½A		017-5268	RT 31B
2 –10	0.3	22	25	G ½A		017-5269	RT 31S
5 –25	0.8 –3	42	47	G ½A	017-5247		RT 32W
5 –25	0.4	42	47	G ½A		017-5248	RT 32B
5 –25	0.4	42	47	G ½A		017-5249	RT 32S

Pressure control for low pressure steam plant (pressure monitoring)

0.1 –1.1	0.07 –0.16	7	7	G ½A	017-5184		RT 112
----------	------------	---	---	------	-----------------	--	--------

Approvals

RT 1	RT 1A RT 5A RT 121	RT 1AL	RT 5	RT 30AW RT 30AB RT 30AS RT 19W RT 19B RT 19S	RT 31W RT 31B RT 31S RT 32W RT 32B RT 32S	RT 33B RT 35W RT 112W RT 116W	RT 110	RT 112	RT 113	RT 116 RT 117 RT 200	RT 117L RT 200L	RT 260A RT 262A RT 265A RT 260AL RT 262AL RT 263AL RT 266AL	Approvals
x	x	x	x	x	x	x	x	x	x	x	x	x	DEMKO, Denmark. CE marked acc. to EN 60947-4/-5
				x	x	x		x					☞ Vd TÜV, Germany
							x	x	x	x			Det Norske Veritas, Norway
			x					x		x			Lloyds Register of Shipping, UK
x			x	x				x		x			© Germanischer Lloyd, Germany
			x					x	x	x			Bureau Veritas, France
x	x	x	x	x	x	x	x	x	x	x	x	x	Registro Italiano Navale, Italy
x	x		x					x	x	x			© Polski Rejestr Statków, Poland
x	x	x	x	x	x	x	x	x	x	x	x	x	RMRS, Russian Maritime Register of Shipping,
x	x		x					x	x	x			Nippon Kaiji Kyokai, Japan

Note: In addition we refer to the certificates, the copies of which can be ordered from Danfoss.

All RT are

- CE marked in accordance with EN 60947-4/-5 for sale in Europe
- Further, the RT 19, RT 30, RT 35, and RT 112 series is CE marked in accordance with PED 97/23/EC, category IV, safety equipment.

Pressure controls, type RT

Technical data

Designation	RT pressure controls
Ambient temperature	In general -50 to 70°C Vd ^{TUV} -approved -40 to +70°C
Contact system	<p>SPDT</p> <p>Line</p> <p>1 2 3 4</p> <p>DANFOSS AGD-969.10</p> <p>Single-pole changeover switch (SPDT)</p>
Contact load	<p>Alternating current: AC-1: 10A, 400 V AC-3: 4A, 400 V AC-15: 3A, 400 V</p> <p>Direct current: DC-13: 12 W, 230 V (see fig. 6)</p>
Contact material: AgCdO	<p>Fig. 6</p> <p>DANFOSS AGD-384.13</p>
Special contact systems	See "accessories" page 28,29
Cable entry	2 PG 13.5 for 6 - 14 mm diameter cables
Enclosure	IP66 acc. to IEC 529 and DIN 40050. Units supplied with external reset IP54. The thermostat housing is made of bakelite acc. to DIN 53470. Cover is made of polyamide.

Materials in contact with the medium

Material	Part	W. no.	DIN	RT 1	RT 1A	RT 5	RT 5A	RT 110	RT 112	RT 113	RT 116	RT 117	RT 121	RT 200/200L	RT 260A	RT 262A/262AL	RT 260AL	RT 265A	RT 263AL/266AL
Stainless steel 18/8	Bellows	1.4301	17440	x	x	x	x	x	x		x	x	x	x	x		x	x	x
Stainless steel 17/7	Spring	1.4568	17224	x						x		x	x	x					
Brass	Housing	2.0402	17660			x		x	x		x	x	x	x					
Brass	Bellows ring	2.0321	17660			x		x	x		x	x	x	x					
Free-cutting steel	Flare connect.	1.0718	1651	x															
Deep-drawn steel (nick.-plated surface)	Housing	1.0338	1623	x	x		x								x	x	x	x	x
Non-alli. carbon steel C20	Weld connect. for connection	1.0402	1652		x		x								x	x	x	x	x
Aluminium	Gasket	3.0255	1712		x		x			x					x	x	x	x	x
Case hardening steel C15	Weld connect. Bellows connet.	1.0401	1652																
Stainless steel	Spring guide + screw	1.4305	17440																
NBR-rubber	Diaphragm									x									
Deep-drawn steel (surface DIN 50961 weld conn. Fe/Zn 5C)	Diaphragm housing with welded connector	1.0338	1623							x									
Spring thread	Spring	1.1250	17223		x														

Materials in contact with the medium. Vd^{TUV} approved controls

Material	Part	W.no.	DIN	RT 19W B,S	RT 30AW AB, AS	RT 31W B, S	RT 32W B, S	RT 33B 35W	RT 112 W	RT 112	RT 116W
Stainless steel 18/8	Bellows	1.4301	17440	x	x	x	x	x	x	x	x
Stainless steel 17/7	Orifice	1.4305	17440	x	x						
Steel C15	Connector	1.0401	1652	x	x						
Deep-drawn steel + Ni	Bellows ring	1.0338	1623	x	x	x	x	x	x		
Stainless steel 17/7	Bellows spring	1.4568	17224		x			x			
Stainless steel	Ring	1.4305	17440		x						
Deep-drawn steel + Ni	Housing	1.0338	1623	x	x	x	x	x	x		
Stainless steel	Bellows connect.	1.4305	17440			x					
Stainless, weldable free-cutting steel	Connector	1.4301	17440			x	x	x	x		x
Deep-drawn steel + Sn	Spring guide	1.0338	1623					x			
Brass	Housing	2.0402	17660							x	x
Brass	Bellows ring	2.0321	17660							x	x

Pressure controls, type RT

Dimensions and weight

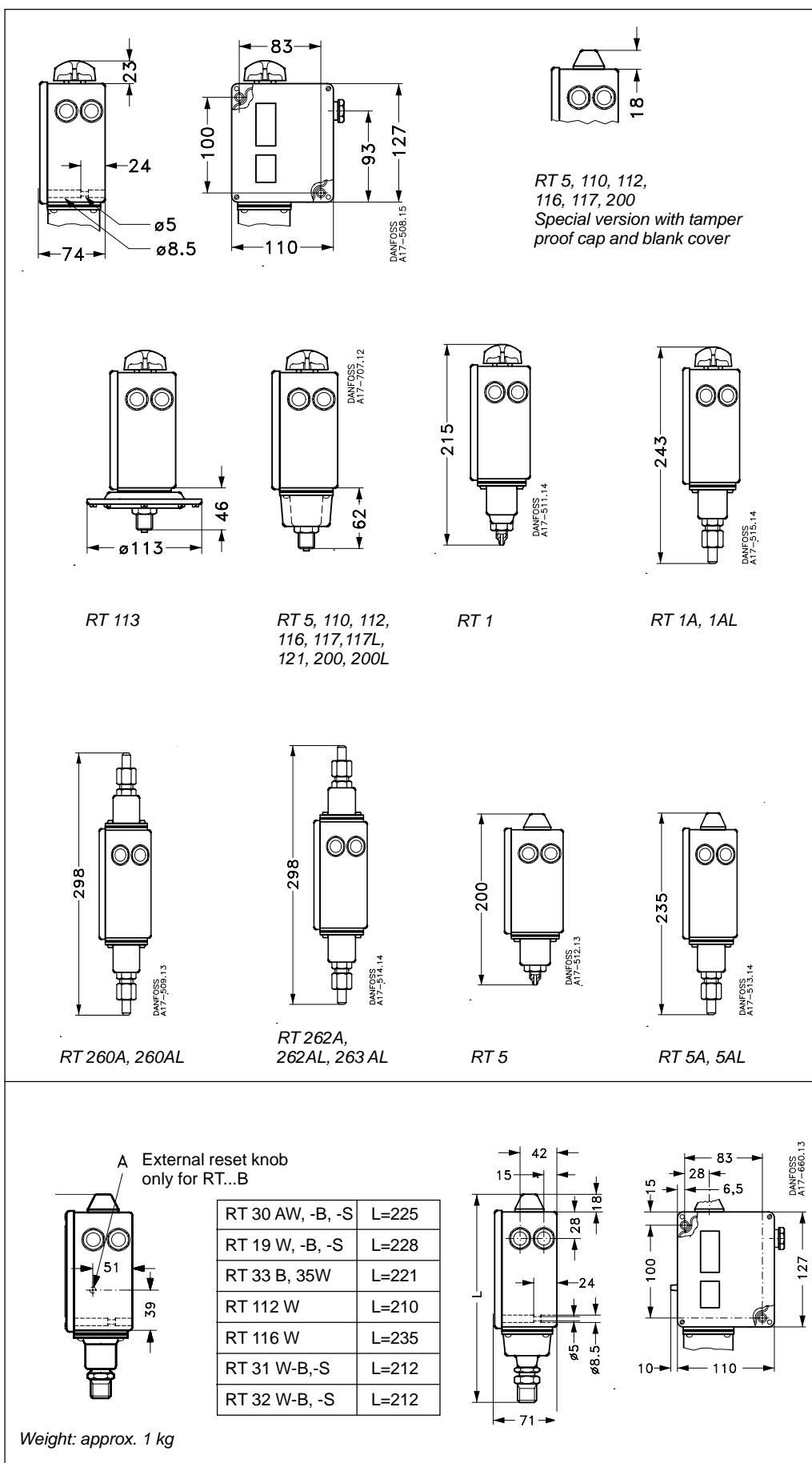

Pressure controls, type RT

Installation

RT units have two mounting holes which become accessible when the front cover is removed. Units fitted with switch 017-0181*) must be installed with the setting knob upwards. When installing differential pressure controls, the low pressure side (marked LP) must be installed upwards. The other pressure controls in the RT series can be installed in any position, expect that on plant subjected to severe vibrations it is advantageous to have the screwed cable entry downwards.

*) Contact system with snap-action contact.
See spare parts and accessories, page 28

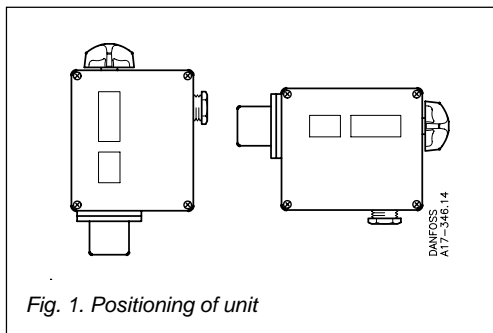

Fig. 1. Positioning of unit

Pressure connection

When fitting or removing pressure lines, the spanner flats on the pressure connection should be used to apply counter-torque.

Steam plant

To protect the pressure element against temperature in excess to the maximum temperature of the medium 150°C (RT 113 90°C), the insertion of water-filled loop is recommended.

Water systems

Water in the pressure element is not harmful, but if frost is likely to occur a water-filled pressure element may burst. To prevent this happening, the pressure control can be allowed to operate on an air cushion.

Media resistance

See table of materials in contact with the medium. If seawater is involved, diaphragm pressure controls types KPS 43, 45 and 47 are recommended.

Pulsations

The pressure control must be connected in such a way that the pressure element is affected by pulsations as little as possible. A damping coil can be inserted (see "Accessories"). With strongly pulsating media, diaphragm pressure controls types KPS 43, 45 and 47 can be advantageous.

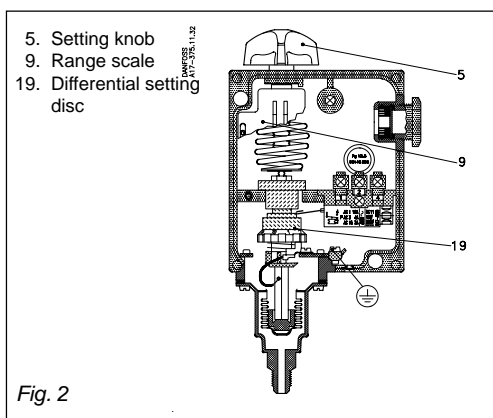

Fig. 2

Setting

The range is set by using the setting knob (5) while at the same time reading the scale (9). Tools must be used to set pressure controls fitted with a seal cap. In units having a fixed differential, the difference between cut-in and cut-out pressures is of course determined. On units having an adjustable differential the front cover must be removed. The differential disc (19) must be set in accordance with the diaphragm.

	1	2	3	4	5	6	7	8	9	10	
RT 1 RT 1A (017-5001)	0,5	0,7	0,9	1,1	1,3	1,5	1,6				bar
RT 1A (017-5007)	1,3	1,5	1,7	1,9	2,1	2,3	2,4				bar
RT 5 RT 5A	1,2	1,6	2,0	2,4	2,8	3,2	3,6	4,0			bar
RT 31W (017-5267)	0,3	0,4	0,5	0,6	0,7	0,8	0,9	1,0			bar
RT 32W (017-5247)	0,8	1,2	1,6	2,0	2,4	2,8	3,0				bar
RT 110	0,08	0,11	0,14	0,17	0,20	0,23	0,25				bar
RT 112	0,07	0,085	0,10	0,115	0,13	0,145	0,16				bar
RT 113	0,01	0,02	0,03	0,04	0,05						bar
		0,015	0,025	0,035	0,045						bar
RT 116	0,3	0,5	0,7	0,9	1,1	1,3					bar
RT 117	1,0	1,5	2,0	2,5	3,0	3,5	4,0				bar
RT 121	0,1	0,15	0,2	0,25	0,3	0,35	4,0				bar
RT 200	0,25	0,4	0,6	0,8	1,0	1,2					bar
Min.	1	2	3	4	5	6	7	8	9	10	Max.

Fig. 3. Obtainable differential disc scale

Selection of differential

To ensure that the plant functions properly, a suitable differential pressure is necessary. Too small a differential will give rise to short running periods with a risk of hunting. Too high a differential will result in large pressure oscillations.

Differential scale values are guiding

Pressure controls, type RT

Function

a. RT 19, RT 30, and pressure controls with max. reset

When the pressure exceeds the set range value, contacts 1-4 make and contact 1-2 brake. The contacts changeover to their initial position when the pressure falls to the range value minus the differential (see fig. 4).

- I. Alarm for rising pressure given at the set range value.
- II. Alarm for falling pressure given at the set range value minus the differential.

Units with max. reset can only be reset at a pressure corresponding to the set range value minus the differential, or a lower pressure.

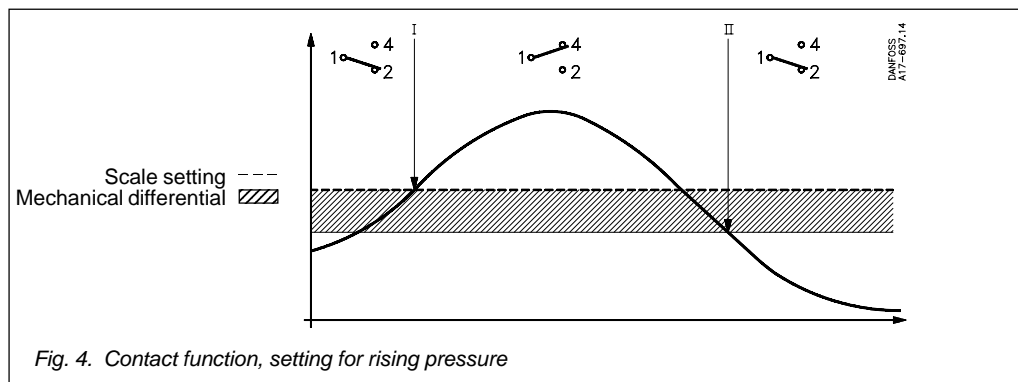

b. All other RT pressure controls

When the pressure falls to the set range value, contacts 1-2 make and contacts 1-4 brake. The contacts changeover to their original position when the pressure again rises to the set range plus the differential (see fig. 5).

- I. Alarm for falling pressure given at the set range value.
- II. Alarm for rising pressure given at the set range value plus the differential.

Units with min. reset can only be reset at a pressure corresponding to the set range value plus the differential.

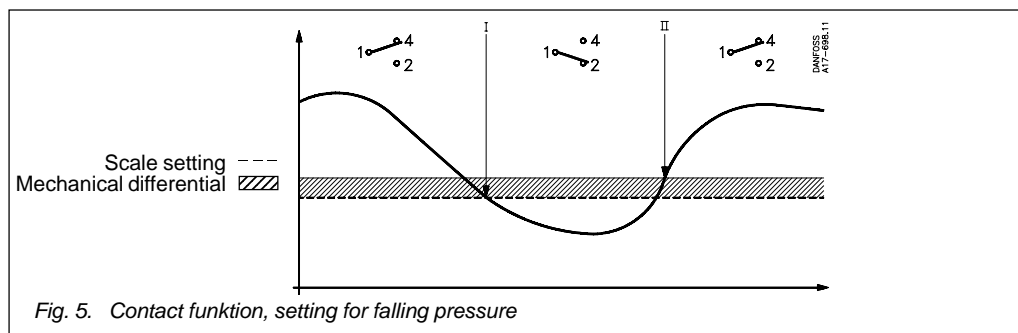

Example 1

An extra cooling water pump must start if the cooling water pressure falls below 6 bar, and must stop when the pressure exceeds 7 bar.

Choose an RT 116 with a range of 1-10 bar and an adjustable differential of 0.2-1.3 bar.

The start pressure of 6 bar must be set on the range scale. The differential must be set as the difference between the stop pressure (7 bar) and the start pressure (6 bar) = 1 bar. According to fig. 3, the differential setting disc must be set on 8.

The range is 5-25 bar and the differential is fixed at approx. 1 bar. The range scale must be set at 17 bar. After cut-out of the burner, manual reset is possible only when the pressure had fallen to the setting of 17 bar minus the differential: in this case, 16 bar and below.

Example 2

The burner on a steam boiler must cut out when the pressure exceeds 17 bar. Automatic restart must not occur.

Choose an RT 19B with external reset. If extra safety is demanded, an RT 19S with internal max. reset can be used.

Example 3

The min. permissible lubricating oil pressure for a gear is 3 bar. Reset must not be possible until the reason for oil pressure failure has been investigated. Choose an RT 200 with min. reset.

The range value must be set while reading the range scale. Manual reset is possible only when the pressure has reached 3.2 bar (the differential is fixed at 0.2 bar or higher).

Pressure controls, type RT

Function description for RT units TUV approval

Fail-safe function for falling pressure

Fig. 5a shows a cross-section of a bellows element for the RT 32W with fail-safe function for falling pressure. On rising pressure the contact arm is actuated to break the connection between terminals 1 and 2.

On falling pressure the contact arm is actuated to break the connection between terminals 1 and 4. If a defect occurs in the bellows the setting spring actuates the contact arm to break the connection between terminals 1 and 4, as in the case of falling pressure. This will occur irrespective of the pressure on the bellows.

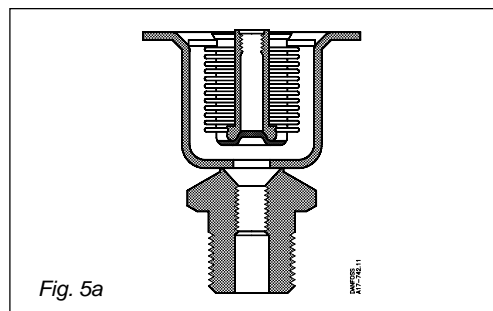

Fig. 5a

Fail-safe function for rising pressure

Fig. 5b shows a cross-section through a bellows element for the RT 30W with fail-safe for rising pressure. On rising pressure the contact arm is actuated to break the connection between terminals 1 and 2. If a defect occurs in the inner bellows the pressure is led to the outer bellows. The outer bellows has an area three times as large as the inner bellows. The connection between terminals 1 and 2 becomes broken.

If a defect occurs in the outer bellows, there will be atmospheric pressure in the gap between the two bellows. This actuates the contact system to break the connection between terminals 1 and 2. The important factor with the double bellows design is the vacuum between the two bellows, and that in case of bellows break, no media will leak into the environment.

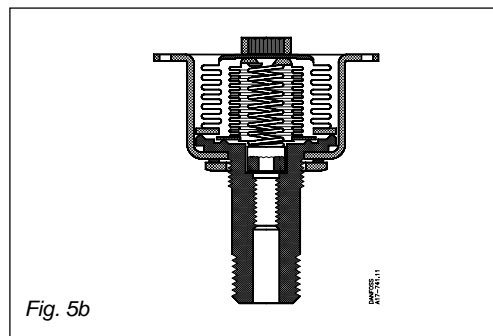

Fig. 5b

Pressure controls for liquid level control RT 113

The RT 113 pressure control can be used to control the liquid level in open tanks. Fig. 6 shows in principle, four different types of installation.

1. With air bell (see "Accessories")

For control purpose, the air bell should be installed 20 to 40 mm below the lowest liquid level. In addition, the tube between the RT 113 and the air bell must be absolutely airtight. If only an indication is required, the bell can be placed 100 mm below the max. level. The RT 113 must be set at 0 cm wg and the differential disc on 1.

2. Connection to the side of the tank with the RT 113 above the liquid level

The horizontal tube A must have a certain length in relation to the vertical tube B in order to ensure reliable control. The length of A can be found from fig. 7, using B and the range setting pressure C.

3. Connection to the side of the tank with the RT 113 below the liquid level

Where possible, this form of connection should be used. If an air-absorbing liquid like oil is involved, it is preferable to 1 and 2. The resulting range setting is the distance from the liquid surface to the centre of the diaphragm housing.

4. Connection in the tank with the RT 113 above the liquid level

This method is for use with air-absorbing liquids where connection type 3 is not possible. The shortest horizontal tube length is determined as described in 2. A shut-off valve is installed between the oil tank and water reservoir shown so that impurities can be drained from the water reservoir through a bottom drain plug. Fresh water can then be poured into the reservoir through a filling connector in its top.

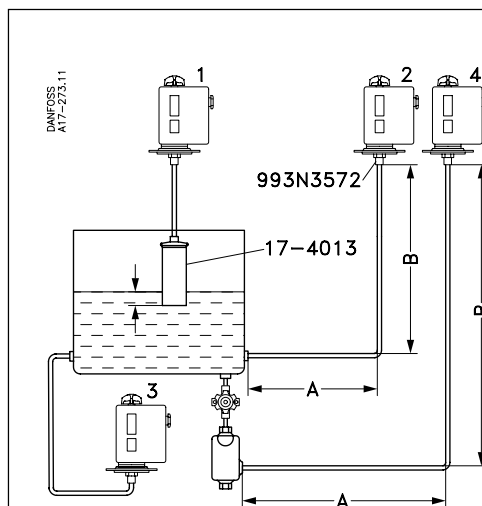

Fig. 6

Height from tank connector to
pressure control

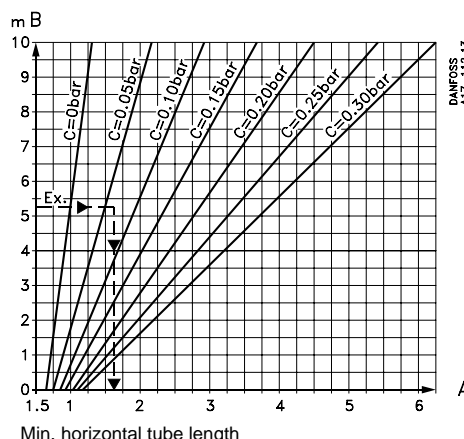
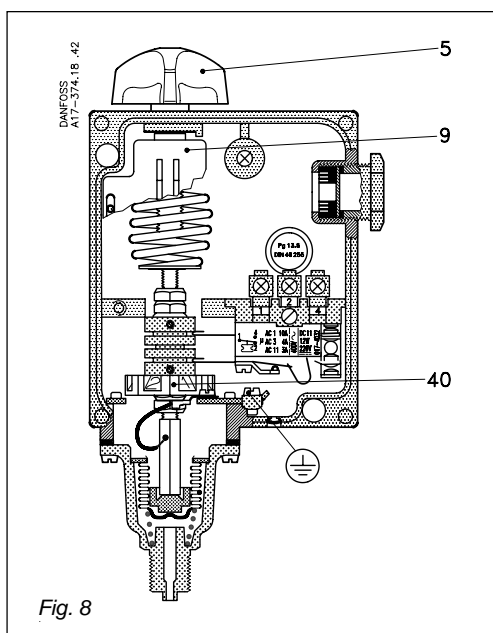

Fig. 7

Pressure controls with adjustable neutral zone, type RT-L

Application



- 5. Setting knob
- 9. Range scale
- 40. Neutral zone disc

RT-L pressure controls are fitted with a switch with an adjustable neutral zone. This enables the units to be used for floating control. The terminology involved is explained below.

Floating control

A form of discontinuous control where the correcting element (e.g. valve, damper, or similar) moves towards one extreme position at a rate independent of the magnitude of the error when the error exceeds a definite positive value, and towards the opposite extreme position when the error exceeds a definite negative value.

Hunting

Periodic variations of the controlled variable from the fixed reference.

Neutral zone

The interval in the controlled variable in which the correcting element does not respond (see fig. 13).

The contact system in neutral zone units cannot be exchanged, as the contact system adjustment is adjusted to the other parts of the unit.

Setting of neutral zone

The range is set using the setting knob (5) fig. 8 while reading the range scale (9). The pressure set is the break pressure for contacts 1-4 (see fig. 13).

The required neutral zone can be found in the diagram for the unit concerned. The position at which the neutral zone disc (40) must be set can be read from the lower scale in the diagram. The function can be seen in fig. 13.

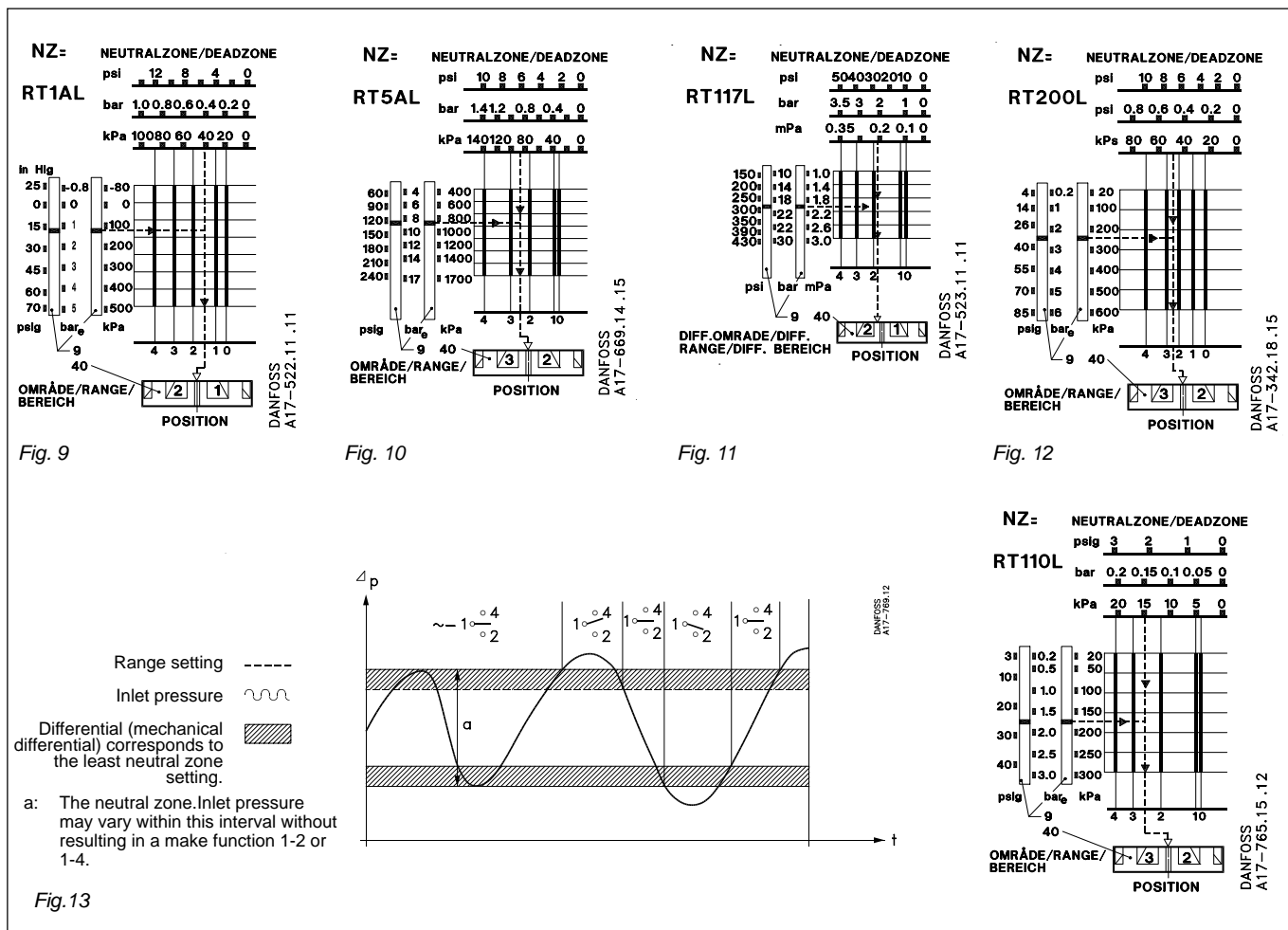

Pressure controls with adjustable neutral zone, type RT-L

Example

Together with a VLT® static frequency converter, RT 200L neutral zone pressure controls can be used for the infinite control of a pump in, for example, a pressure boosting plant.

In this case, the pump must be up and down-regulated at 32 and 25 m wg.

The RT 200L must be set using the setting knob (5) fig. 8 page 11 at 3.5 bar (35 m wg) minus the fixed differential of 0.2 bar.

The range setting is $3.5 - 0.2 = 3.3$ bar.

The neutral zone, $35 - 32 = 3$ m wg, corresponding to 0.3 bar, must be set on the neutral zone disc (40) fig. 8 page 11. According to the diagram fig. 12 the disc setting is 1 or just over. A more accurate setting can be obtained by using the test setup shown in fig. 14.

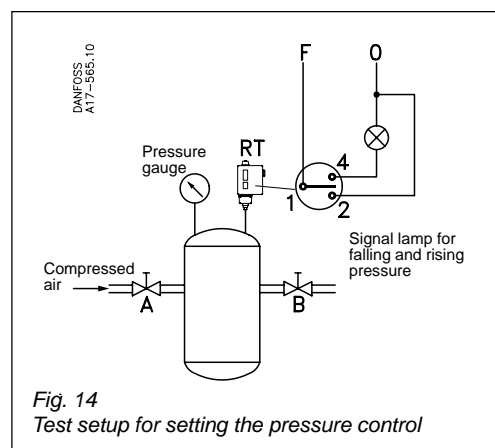

Fig. 14
Test setup for setting the pressure control

Differential pressure control, type RT

Application

Control and monitoring of pressure differentials
 A differential pressure control is a pressure controlled switch that cuts in and cuts out the current dependent on the pressure differential between the

counteracting bellows elements and the set scale value. This unit is also available with an adjustable neutral zone (like the RT-L which is described on page 11.)

Setting

- 5. Setting disc
- 9. Range scale

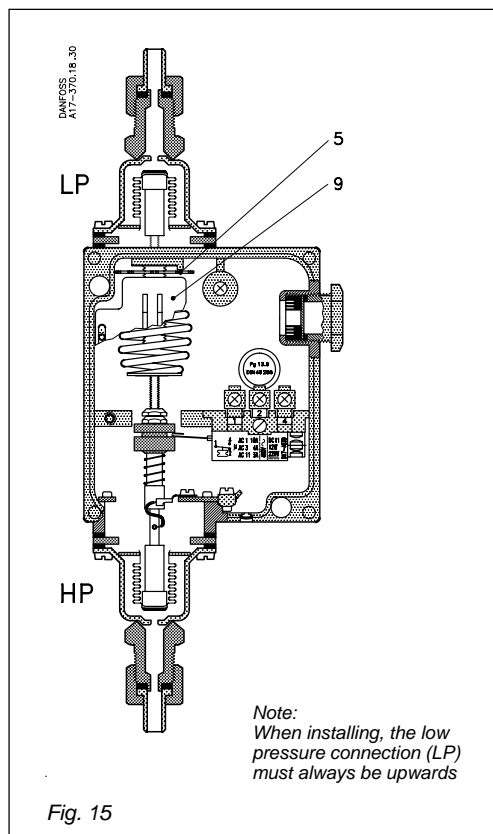

Fig. 15

The setting disc (5) becomes accessible when the front cover is removed. The differential pressure is set by turning the disc with a screwdriver while reading the scale (9).

For differential pressure controls with a changeover contact system, the contact differential is given as the differential pressure controls have a fixed differential.

In units with an adjustable neutral zone, the neutral zone disc must also be set. See diagram in fig. 16.

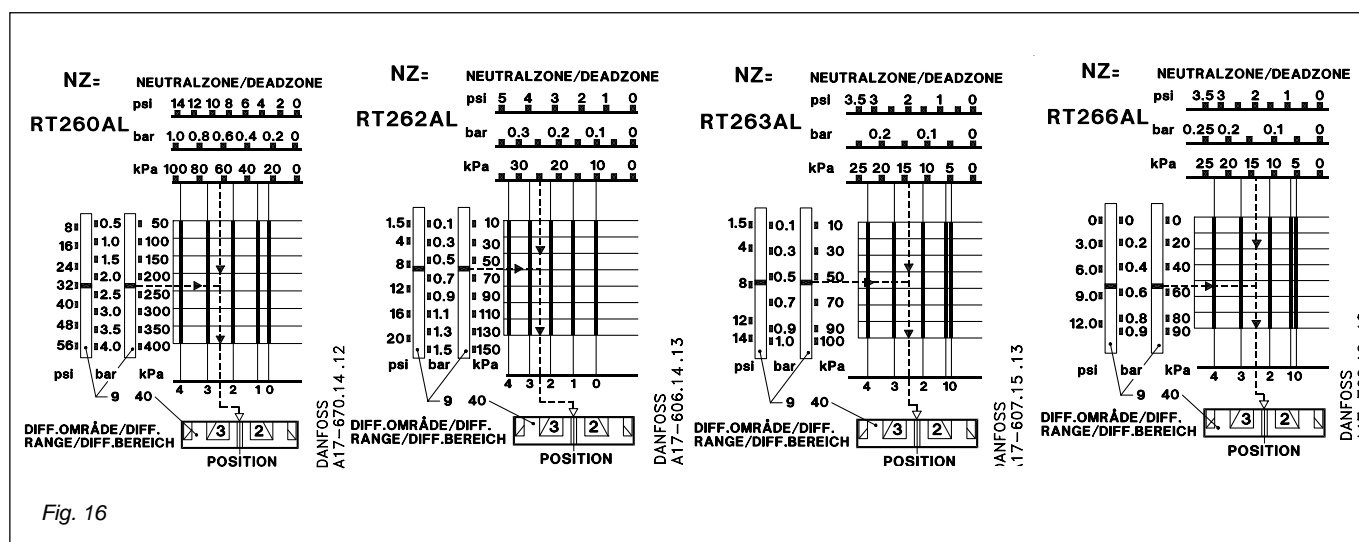

Fig. 16

Differential pressure controls, type RT

Function

a. Units with changeover switch (SPDT)

If the differential pressure falls below the set value, contacts 1-2 make and contacts 1-4 break.

Contacts 1-2 break again and contacts 1-4 make when the differential pressure has risen to the set range value plus the fixed contact differential.

I. Contacts make when differential pressure falls below the range scale setting.

II. Contacts make when pressure rises above the range scale setting plus the fixed mechanical differential.

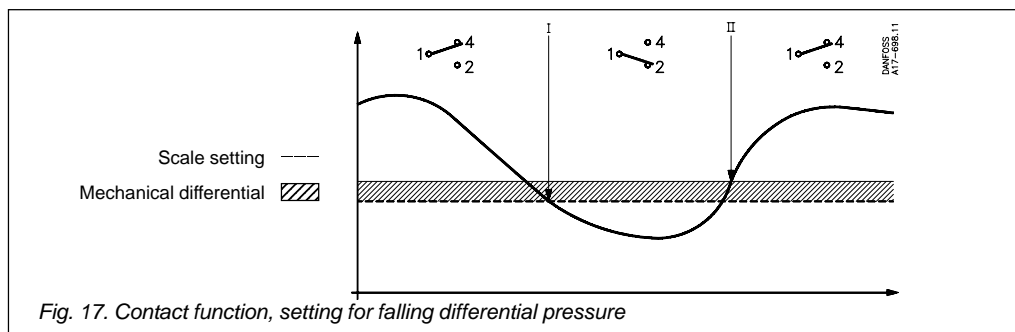

Fig. 17. Contact function, setting for falling differential pressure

b. Units with adjustable neutral zone (SPDTNP)

If the differential pressure rises above the set value plus the differential, contacts 1-4 make.

If the pressure falls by the amount of the differential (which is fixed in this unit), contacts 1-4 break.

If the pressure falls to the neutral zone minus the differential, contacts 1-2 make. When the differential pressure rises again by an amount corresponding to the differential, contacts 1-2 break again.

The contact function can be summed up as follows:

- I. Setting disc set for falling differential pressure.
- II. Neutral zone disc set for rising differential pressure.

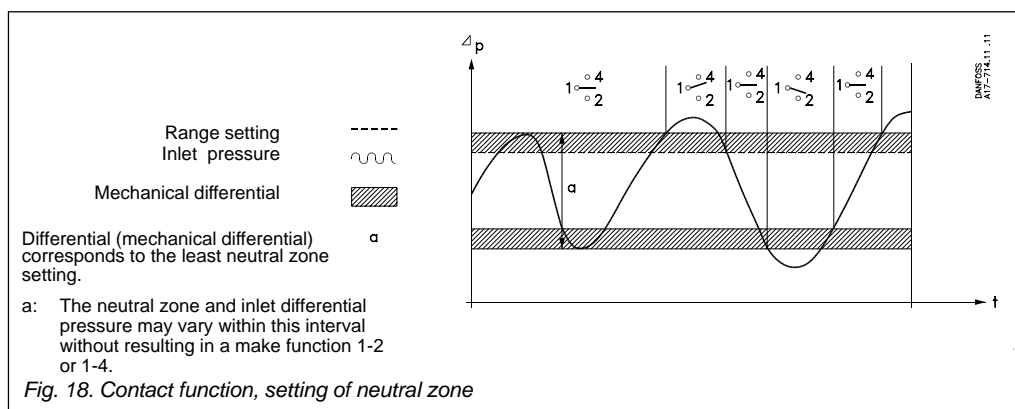

Fig. 18. Contact function, setting of neutral zone

Example 1

When the differential pressure exceeds 1.3 bar, a filter needs cleaning. The static pressure over the filter is 10 bar.

According to the ordering table on page 4, the choice is an RT 260A (the RT 262A has a max. operating pressure on the low pressure side (LP) of 6 bar and is therefore not suitable for this application).

Setting: Since a signal is required for rising differential pressure, the setting becomes 1.3-0.3 bar = 1.0 bar.

Example 2

The speed of a circulation pump must be controlled to give a constant differential pressure of 10 m wg in a heating plant. The static plant pressure is 4 bar.

The choice is an RT 262AL.

The differential disc (5) fig. 15 page 13, must be set at 1 bar (10 m wg) minus the fixed differential of 0.1 bar, i.e. 0.9 bar. The neutral zone disc is factory-set (marked in red).

Thermostats, type RT

Contents

	Page		Page
Survey of types, temperature ranges	3	Installation, setting	22
Introduction	15	Function	23
Technical data and code nos., all types	16-17	Types of charge	24
Nomograms	18-19	Thermostat for control of ventilation plant	25
Technical data	20	Thermostats with adjustable neutral zone	26
Approvals	20	Differential thermostats	27
Dimensions and weight	21	Spare parts and accessories	28-31

Introduction

A thermostat is a temperature-controlled switch. The position of the contacts depends on the temperature of the sensor and the set scale value.

The RT series covers thermostats for general industrial and marine applications, including differential thermostats with room sensors, duct sensors, and capillary tube sensors

Setting range knob
(Seal cap for tamper proof available)

Polyamide cover
(Cover without windows available)

Stainless steel bellows

IP66 enclosure
(units with external reset IP 54)

2 x PG 13.5
Cable diameter 6 → 14 mm

SPDT contact system.
Exchangeable. Several types of contact systems as spare parts, among other things gold-plated contacts

Capillary tube length up to 10 m.
Also types with room sensors and duct sensors

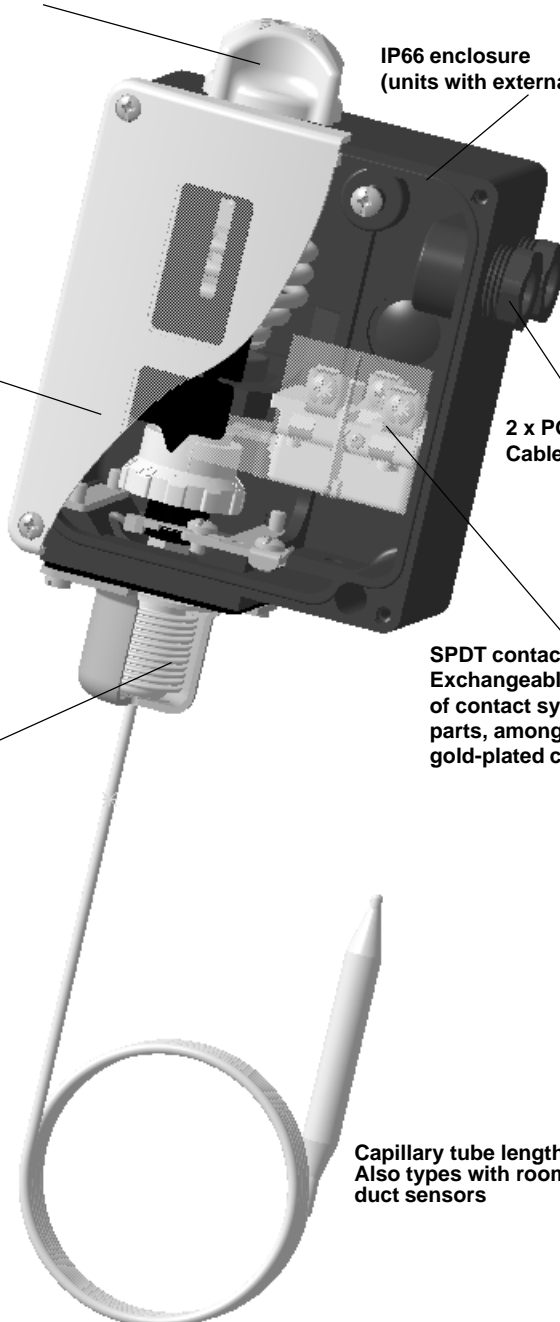

Thermostats, type RT

Technical data and code nos.

When ordering, please state type and code number.

Types of charge

- A: Vapour charge - sensor must not be the warmest part.
- B: Adsorption charge
- C: Partial charge - the sensor must not be the coldest part

Thermostats with cylindrical remote sensor

Preferred charge



RT 107
with cylindrical remote sensor, cover with windows, and hand setting knob

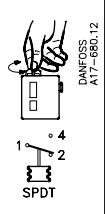
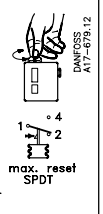
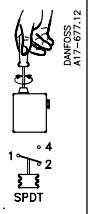

RT 106
with cylindrical remote sensor, cover with windows, and hand setting knob

Setting range °C	Adjustable differential range*)		Max. sensor temp. °C	Type - of charge	Capillary tube length m	Code nos.			Type
	at lowest range setting °C	at highest range setting °C							
-60- -25	1.7- 7	1- 3	150	A	2	017-5077			RT 10
-45- -15	2.2- 10	1- 4.5	150	A	2	017-5066			RT 9
-30- 0	1.5- 6	1- 3	150	A	2	017-5097			RT 13
-25- 15	2.8- 10	1- 4	150	A	2	017-5014			RT 3
-25- 15	2.8- 10	1- 4	150	A	5	017-5016			RT 3
-25- 15	2.8- 10	1- 4	150	A	8	017-5017			RT 3
-25- 15	5- 18	6- 20	150	B	2	017-5008			RT 2
-25- 15	2- 10	2.5- 14	150	B	2	017-5053			RT 7
-25- 15	2- 10	2.5- 14	150	B	5	017-5055			RT 7
-25- 15	2- 10	2.5- 14	150	B	8	017-5056			RT 7
-20- 12	1.5- 7	1.5- 7	145	B	2	017-5063			RT 8
-5- 10	1- 3.5	1- 3	65	B	2	017-5089			RT 12
-5- 30	2- 8	2- 10	150	B	2	017-5099			RT 14
-5- 30	2- 8	2- 10	150	B	3	017-5100			RT 14
-5- 30	2- 8	2- 10	150	B	5	017-5101			RT 14
-5- 30	2- 8	2- 10	150	B	8	017-5102			RT 14
-5- 30	2- 8	2- 10	150	B	10	017-5103			RT 14
-5- 50	2- 9	3- 19	150	B	2	017-5180			RT 26
5- 22	1.1- 3	1- 3	85	B	2	017-5278			RT 23
8- 32	1.6- 8	1.6- 8	150	B	2	017-5115			RT 15
0- 85	6.5 fixed		200	B	2	017-5264⁴⁾			RT 109
25- 90	2.4- 10	3.5- 20	300	B	2	017-5003	017-5004	017-5005	RT 101
25- 90	2.4- 10	3.5- 20	300	B	3	017-5006			RT 101
25- 90	2.4- 10	3.5- 20	300	B	5	017-5022	017-5023		RT 101
25- 90	2.4- 10	3.5- 20	300	B	8	017-5024			RT 101
25- 90	2.4- 10	3.5- 20	300	B	10	017-5025			RT 101
20- 90	4- 20	2- 7	120	C	2	017-5048		017-5049	RT 106
20- 90	4- 20	2- 7	120	C	3			017-5051	RT 106
20- 90	4- 20	2- 7	120	C	5	017-5050			RT 106
30- 140	5- 20	4- 14	220	B	2	017-5060			RT 108
70- 150	6- 25	1.8- 8	215	C	2	017-5135	017-5136	017-5137	RT 107
70- 150	6- 25	1.8- 8	215	C	3	017-5139			RT 107
70- 150	6- 25	1.8- 8	215	C	5	017-5140	017-5141	017-5143	RT 107
70- 150	6- 25	1.8- 8	215	C	8	017-5144			RT 107
70- 150	6- 25	1.8- 8	215	C	10	017-5145			RT 107
120- 215	7- 30	1.8- 9	260	C	2	017-5205¹⁾	017-5211¹⁾	017-5210	RT 120
120- 215	7- 30	1.8- 9	260	C	5	017-5206¹⁾	017-5212¹⁾		RT 120
120- 215	7- 30	1.8- 9	260	C	8	017-5207¹⁾			RT 120
120- 215	7- 30	1.8- 9	260	C	2	017-5208	017-5214²⁾		RT 120
120- 215	7- 30	1.8- 9	260	C	5	017-5209			RT 120
150- 250	6.5- 30	1.8- 9	300	C	2	017-5220	017-5224	017-5225	RT 123
150- 250	6.5- 30	1.8- 9	300	C	5	017-5222			RT 123
150- 250	6.5- 30	1.8- 9	300	C	8	017-5223			RT 123
200- 300	5- 25	2.5- 10	350	C	2	017-5227	017-5231		RT 124
200- 300	5- 25	2.5- 10	350	C	5	017-5229			RT 124

*)See also pages 18-19

¹⁾Thermostats fitted with neon lamp connected to terminal 4

²⁾Thermostat with tamper-proof seal cap

³⁾Thermostat with max. reset has fixed differential corresponding to min. setting differential

⁴⁾Fail safe thermostat

Thermostats, type RT



Thermostat type RT 115
with room sensor



Thermostat type RT 140
with duct sensor



Neutral zone thermostat
type RT 16L
with room sensor



Differential thermostat
type RT 270

Thermostats with room sensor, duct sensor and capillary tube sensor Preferred versions

Setting range °C	Adjustable differential range*)		Max. sensor temp. °C	Type of charge	Capillary tube length m	Sensor type**) Figure	Code no.	Type
	at lowest range setting °C	at highest range setting °C						
-50- -15	2.2- 7	1.5- 5	100	A	-	1	017-5117	RT 17
-30- 0	1.5- 6	1- 3	66	A	-	1	017-5083	RT 11
-25- 15	2- 10	2- 12	100	B	-	1	017-5118	RT 34
-5- 30	1.5- 7	1.2- 4	75	A	-	1	017-5036	RT 4
-5- 30	1.5- 7	1.2- 4	75	A	-	1	017-5037 ¹⁾	RT 4
10- 35	⁵⁾	⁵⁾	92	B	-	1	017-5197 ²⁾	RT 115
10- 35	⁵⁾	⁵⁾	92	B	-	1	017-5198 ³⁾	RT 115
10- 45	1.3- 7	1- 5	100	A	-	1	017-5155	RT 103
10- 45	1.3- 7	1- 5	100	A	-	1	017-5157 ⁴⁾	RT 103
15- 45	1.8- 8	2.5- 11	240	B	2	2	017-5236	RT 140
40- 80	1.9- 9	2.5- 17	250	B	2	2	017-5241	RT 141
25- 90	2.4- 10	3.5- 20	300	B	2	3	017-5147	RT 102
25- 90	Max. reset	Max. reset	300	B	2	3	017-5151 ⁴⁾	RT 102
25- 90	2.4- 10	3.5- 20	300	B	5	3	017-5149	RT 102
25- 90	2.4- 10	3.5- 20	300	B	8	3	017-5150	RT 102

*) See also pages 18-19

***) See also fig. 1-5

¹⁾ Bellows with built-in heating element which reduces the thermal differential (220V)

²⁾ Can be connected to 220 V and 380 V

³⁾ Can be connected to 220 V

⁴⁾ Thermostat with max. reset

⁵⁾ Special thermostat for ventilation plant

Thermostats with adjustable neutral zone

Setting range °C	Adjustable neutral zone		Max. sensor temp. °C	Type of charge	Capillary tube length m	Sensor type*) Figur	Code no.	Type
	at lowest setting °C	at highest setting °C						
-20- 12	1.5- 4.4	1.5- 4.9	145	B	2	4	017L0030	RT 8L
-5- 30	1.5- 5	1.5- 5	150	B	2	4	017L0034	RT 14L
0- 38	1.5- 5	0.7- 1.9	100	A	-	1	017L0024	RT 16L
15- 45	1.8- 4.5	2- 5	240	B	2	2	017L0031	RT 140L
25- 90	2.5- 7	3.5- 12.5	300	B	2	4	017L0062	RT 101L

*) See fig. 1-5

Differential thermostats

Setting range (diff. temp.) °C	Mechanical differential °C	Operating range (LT element) °C	Max. sensor temp. °C	Type of charge	Capillary tube length m	Sensor type*) Figur	Code no.	Type
0-15	2	-30 to 40	65	B	2 x 5	5	017D0031	RT 270
0-20	3	20 to 100	200	B	2 x 10	5	017D0044	RT 271

*) See fig. 1-5

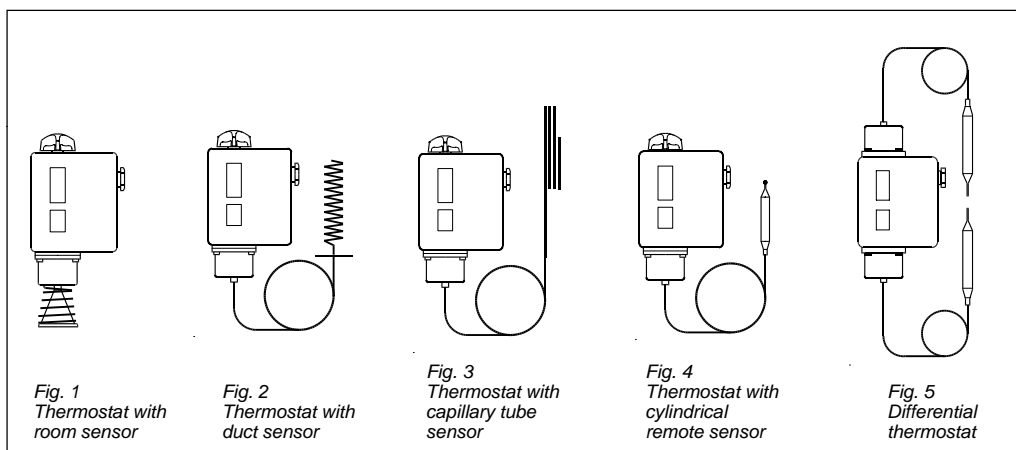

Fig. 1
Thermostat with
room sensor

Fig. 2
Thermostat with
duct sensor

Fig. 3
Thermostat with
capillary tube
sensor

Fig. 4
Thermostat with
cylindrical
remote sensor

Fig. 5
Differential
thermostat

Thermostats, type RT

Nomograms for obtained differentials

A = Range setting
 B = Obtained differential
 C = Differential setting

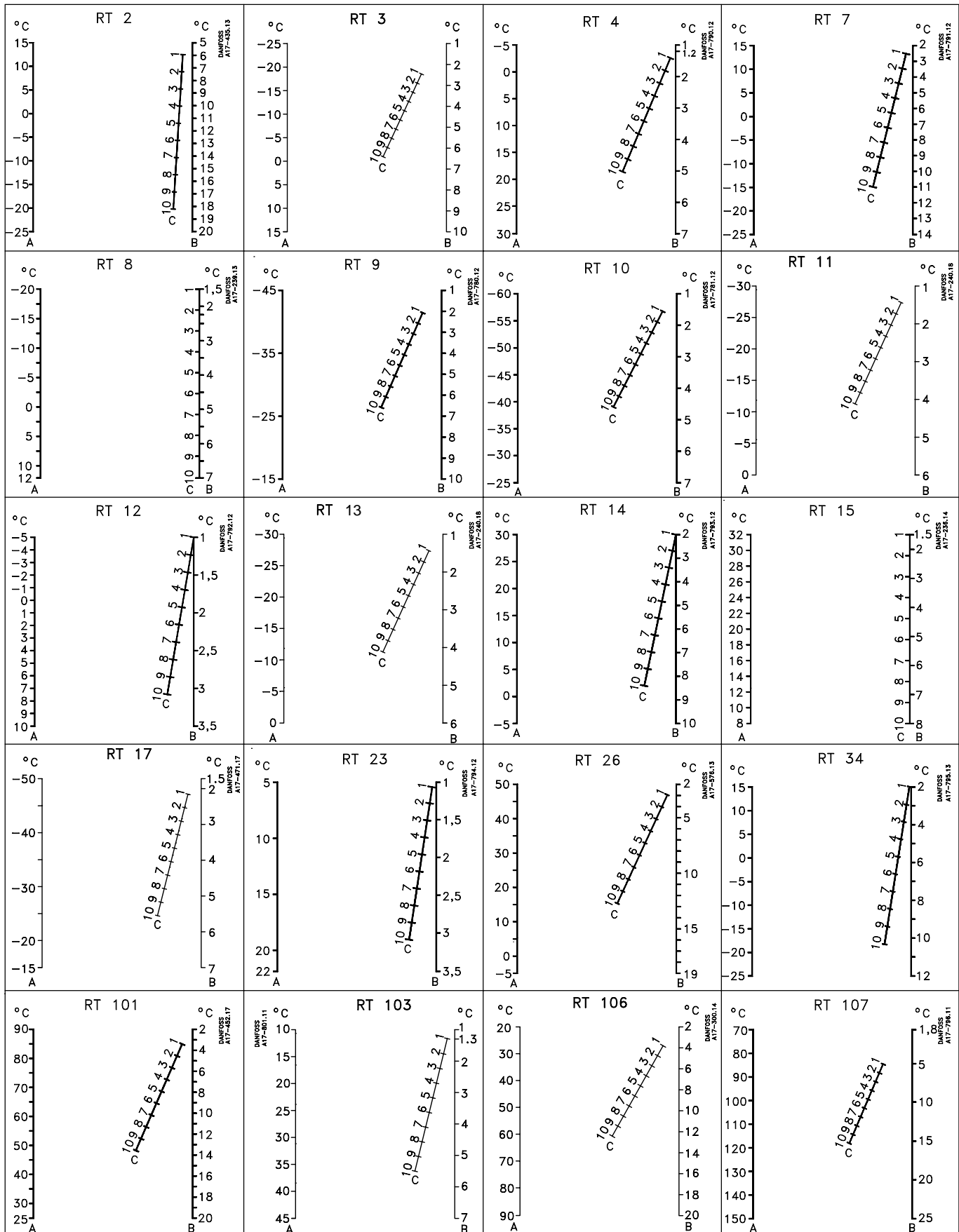

Thermostats, type RT

Nomograms for obtained differentials

A = Range setting
 B = Obtained differential
 C = Differential setting

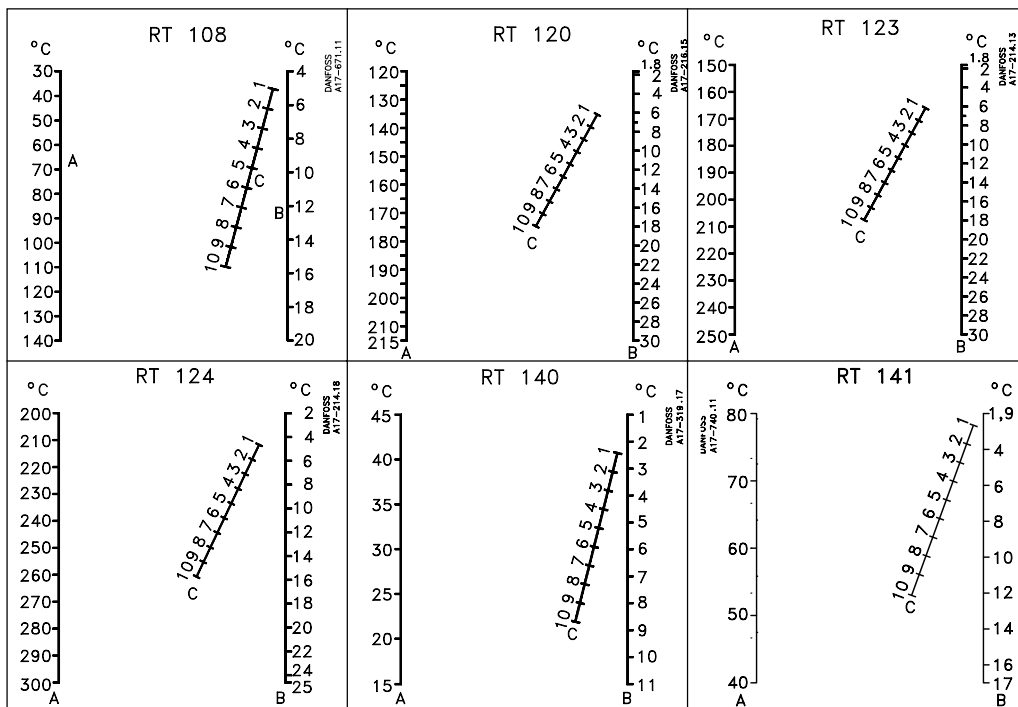

Thermostats, type RT

Technical data

Designation	RT thermostats
Ambient temperature	-50 to 70°C. See remarks on charge types page 16
Contact system	<p>Single-pole changeover switch (SPDT)</p>
Contact load	<p>Alternating current: AC-1: 10A, 400 V AC-3: 4A, 400 V AC-15: 3A, 400 V</p> <p>Direct current: DC-13: 12 W, 230 V (see fig. 6)</p>
Contact material: AgCdO	
Special contact systems	See accessories page 28, 29
Cable entry	2 PG 13.5 for 6 - 14 mm diameter cable
Enclosure	IP66 acc. to IEC 529 and DIN 40050. Units with external reset IP54. Thermostat housing is made of bakelite acc. to DIN 53470, while the cover is made of polyamid.

Approvals

RT 2 RT23 RT 26 RT 108	RT4 RT10 RT11 RT 16L RT17 RT140L	RT3 RT7 RT8 RT8L RT9	RT12 RT13 RT14 RT14L RT15	RT16 RT102 RT141 RT271 RT270	RT34 RT103 RT115 RT140	RT101	RT106 RT107 RT123	RT120	RT124	Approvals
x	x	x	x	x	x	x	x	x	x	DEMKO, Denmark. CE-market acc. to EN 60947-4/-5, EN 60730-2-1/-9
						x	x	x	x	Det Norske Veritas, Norway
							x			Lloyds Register of Shipping, UK
		x	x			x	x	x		Germanischer Lloyd, Germany
						x				Bureau Veritas, France
x	x	x	x	x	x	x	x	x	x	Registro Italiano Navale, Italy
x	x	x	x				x	x	x	Polski Rejestr Statków, Poland
x	x	x	x	x	x	x	x	x	x	RMRS, Russian Maritime Register of Shipping,
x		x	x			x	x	x	x	Nippon Kaiji Kyokai, Japan

Note: In addition we refer to the certificates, the copies of which can be ordered from Danfoss.
 GL approval is conditional on the use of a ship's cable entry

Identification

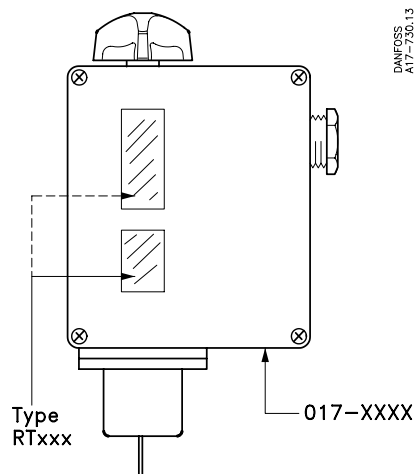

The type designation of the units is given on the setting scale. The code no. is stamped on the bottom of the thermostat housing

Thermostats, type RT

Dimensions and weight

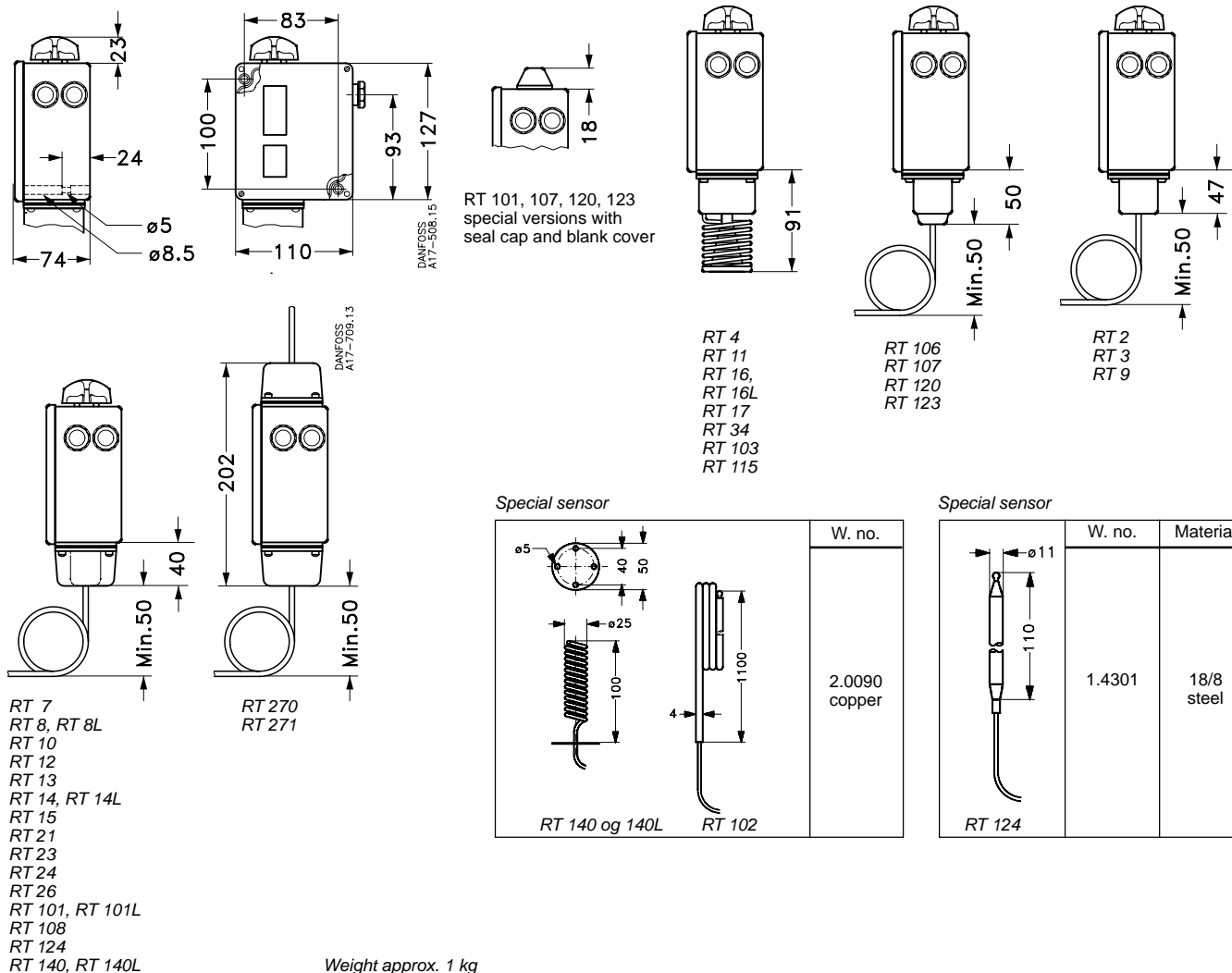

Special sensor

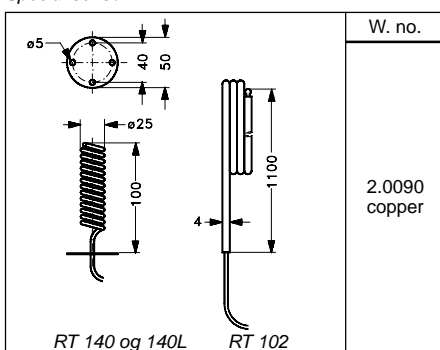

Special sensor

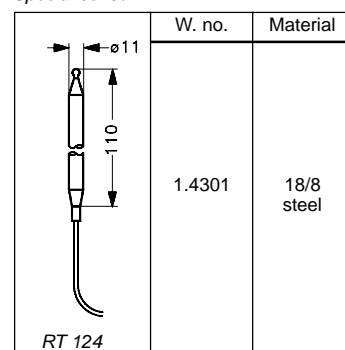

Choice of suitable sensor pocket

W.no.	Type	Capillary tube length m	L mm	Suitable sensor pocket Code no.	Material	W.no.	L mm	a ₁ mm	d mm
2.0090 copper	RT2/3/7/9/ 10/13/26/120	2, 3, 5, 8, 10	80	017-4370	Brass	2.0321	112	G ½	11
				017-4369	18/8 steel	1.4301			
	RT101/101L	2,3	110	017-4370	Brass	2.0321	112	G ½	11
				017-4369	18/8 steel	1.4301			
	RT8,8L/14/14L, 15,107, 123, 270	2, 3, 5, 8, 10	110	017-4370	Brass	2.0321	112	G ½	11
				017-4369	18/8 steel	1.4301			
	RT101	5,8,10	110	017-4370	Brass	2.0231	112	G ½	11
017-4369				18/8 steel	1.4301				
RT14/ 271	10	150	017-4367	Brass	2.0321	182	G ½	11	
RT271	10	180	017-4216	Brass	2.0321	465	G ½	11	
RT12/23	2	210	017-4216	Brass	2.0321	110	G ½	15	
2.0240 brass	RT106	2.3	76	060L3330 060L3327	Brass	2.0235	160	G ½	15
				060L3331 060L3329	18/8 steel	1.4301	110	G ½	15
		5	86	060L3330 060L3327	Brass	2.0235	110	G ½	15
				060L3331 060L3329	18/8 steel	1.4301	110	G ½	15
Sensor pocket, solid version. internal diameter 13.1mm				017-4218	AISI 316L	1.4435	108	G ½	15.7

Thermostats, type RT

Installation

RT units have two fixing holes which become accessible when the front cover is removed. Units fitted with switch 017-0181*) must be installed with the setting knob upwards. The other thermostats in the RT series can be installed in any position, except that on plant subjected to severe vibrations it is advantageous to have the screwed cable entry downwards.

*) Contact system with snap-action function.
See spare parts and accessories, page 28

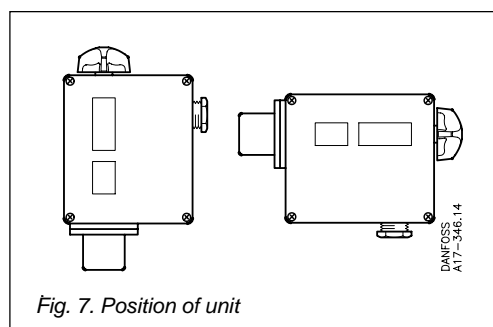

Fig. 7. Position of unit

Setting

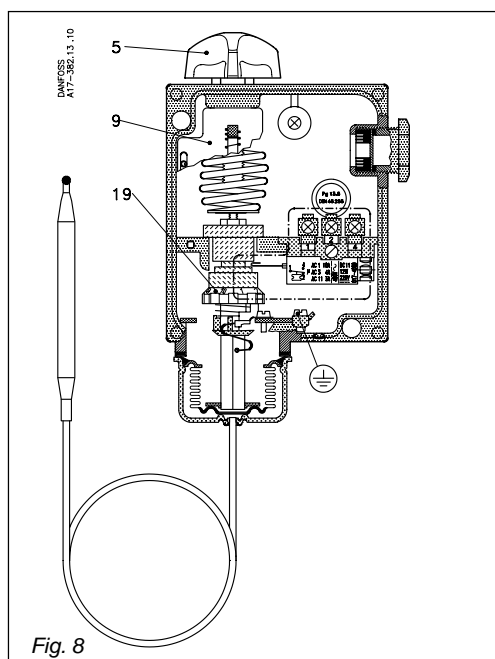

Fig. 8

- 5. Setting knob
- 9. Main scale
- 19. Differential setting disc

The range is set by using the setting knob (5) while at the same time reading the main scale (9). Tools must be used to set thermostats fitted with a seal cap. The differential is set by the differential disc (19).

The size of the obtained differential can be established by comparing the set main scale value and the scale value on the differential disc, with the help of the nomogram for the thermostat concerned (see pages 18-19)

Example

Unit: RT 120
Range setting: 160°C
Differential setting: 2

It will be seen on the nomogram on page 19 that by drawing a line from 160°C on scale A, through 2 on scale C, the value for the differential can be read from scale B: 6°C.

Selection of differential (mechanical differential)

To ensure that the plant functions properly, a suitable differential is necessary. Too small a differential will give rise to short running periods with a risk of hunting. Too high a differential will result in large temperature variations.

Differentials

The mechanical differential is the differential that is set on the differential disc in the thermostat.

The thermal differential (operating differential) is the differential the system operates on. The thermal differential is always greater than the mechanical differential and depends on three factors:

- 1) flow velocity of the medium
- 2) temperature charge rate of the medium and
- 3) heat transmission

The medium

The fastest reaction is obtained from a medium having high specific heat and high thermal conductivity. It is therefore advantageous to choose a medium that fulfills these conditions (provided there is a choice). The flow velocity of the medium is also of significance. (Optimum flow velocity for liquids is approx. 0.3 m/s).

Example:

Regulation of a central heating boiler

The temperature in an oil-fired central heating boiler must be regulated by an RT 101. Max. temperature 76°C. Min. temperature 70°C.
Differential $76 - 70 = 6^\circ\text{C}$.

1. Connect the oil burner via thermostat terminals 1-2.
 2. Set the thermostat on 70°C using the hand knob (5), fig. 8.
 3. Set the differential disc (19) on 3. This figure is obtained from the RT 101 nomogram, page 18.
- When the plant has been operating for some time an assessment can be made of whether the thermal differential is satisfactory. If it is too large, reduce the mechanical differential of the thermostat.

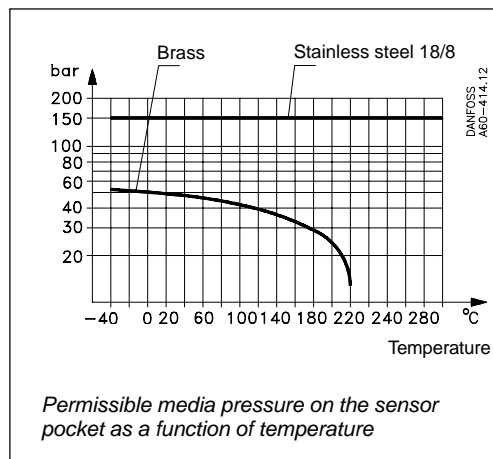

Permissible media pressure on the sensor pocket as a function of temperature

Thermostats, type RT

Function

a. RT thermostats with automatic reset

The RT thermostats are set according to the function required on falling temperature. Contacts 1-4 break while contacts 1-2 make when the temperature falls to the scale setting. The contacts changeover to their initial position when the temperature again rises to the scale setting plus the differential (see fig. 9).

Contact function

- I. Contact changeover for rising temperature occurs at scale setting plus differential..
- II. Contact changeover for falling temperature occurs at scale setting.

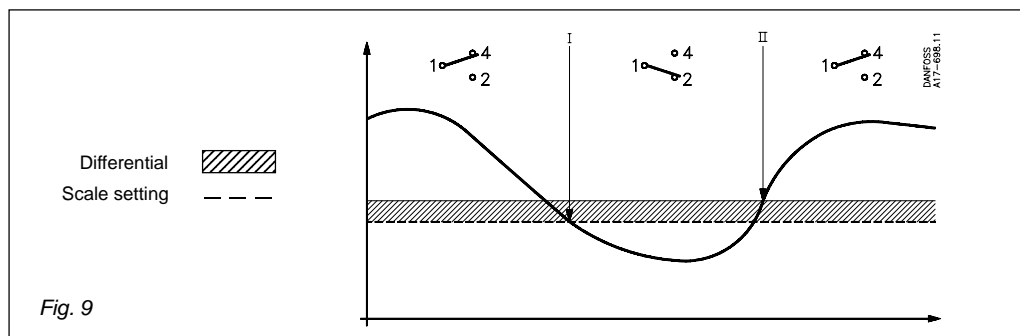

b. RT thermostats with max. reset

Contacts 1-4 make while contacts 1-2 break when the temperature exceeds the set range value. The contacts changeover to their initial position when the temperature falls to the scale value minus the differential (see fig. 10).

- I. Alarm for rising temperature given at the set value.
- II. Alarm for falling temperature given at the set value minus the differential.

Manual reset possible only when the temperature has fallen to the range setting minus differential.

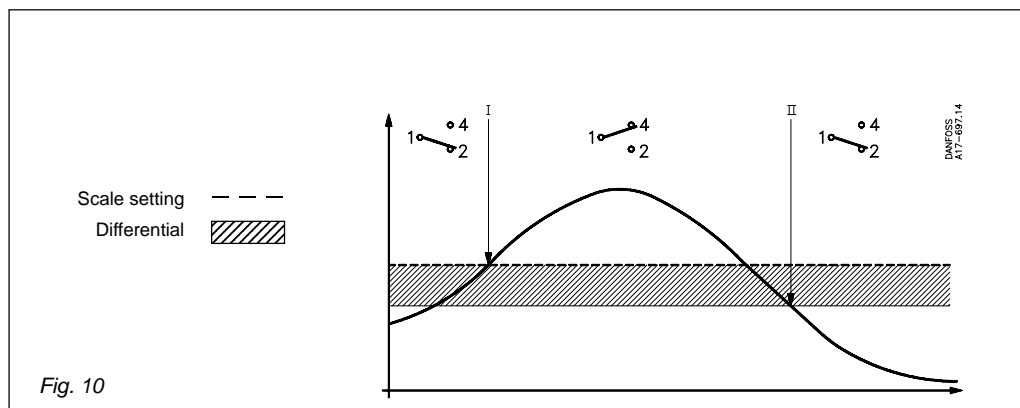

Thermostats, type RT

RT units with vapour charge

The method of operation of these units is based on the connection between the pressure and temperature of saturated vapour. The sensor system contains just a small amount of liquid and this is brought completely to vapour form. If the sensor in this type of unit is located coldest in relation to the capillary tube and bellows housing, the ambient temperature has no influence on regulation accuracy.

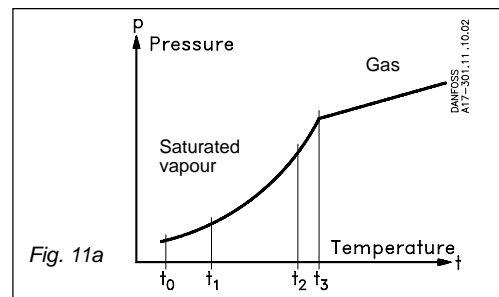

RT units with adsorption charge

The thermostatic element contains a superheated gas together with a solid substance (always in the sensor) having a large adsorption surface. This gives an advantage in that the sensor can be installed either colder or warmer than the remaining part of the thermostatic element. However, the charge is to some extent sensitive to changes in the temperature of the bellows and capillary tube.

Scale correction

If the thermostat is to be used in ambient temperatures that differ significantly from the factory setting (20°C), compensation can be made for the scale deviation:

Scale correction = $Z \times a$

Z can be found from fig. 11c, while a is the correction factor from the table.

Example:

Find the necessary scale correction for a RT 108 with a regulation range +30 to +140°C.

Setting: 85°C

Ambient temperature: 50°C

Correction:

$$\frac{\text{Set value} - \text{min. scale value}}{\text{max. scale value} - \text{min. scale value}} \times 100 = \%$$

$$\frac{85 - 30}{140 - 30} \times 100 = 50\%$$

Correction factor from table 2.0 (a)

Factor for scale deviation (see fig. 11c): +1.2 (Z)

Scale correction: $Z \times a = 1.2 \times 2.0 = 2.4^\circ\text{C}$

Corrected setting: $85 + 2.4 = 87.4$

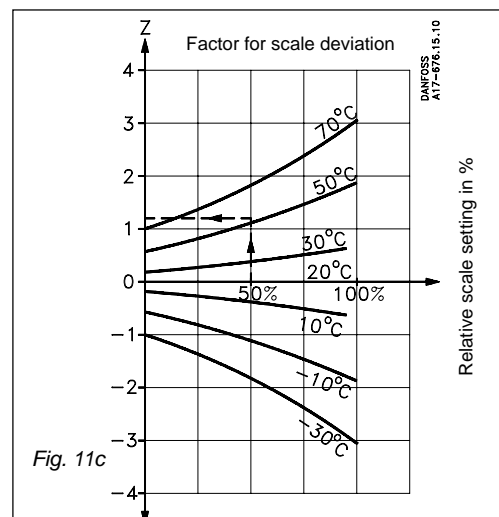
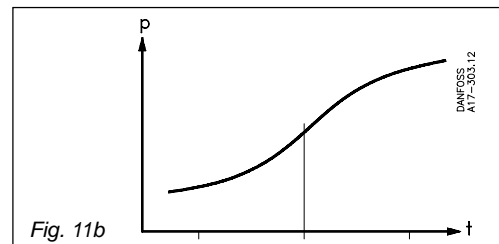

Type	Range °C	Correction factor a
RT 2	-25- 15	2.3
RT 7	-25- 15	2.9
RT 8/L	-20- 12	1.7
RT 12	-5- 10	1.2
RT 14/L	-5- 20	2.4
RT 15	8- 32	1.2
RT 23	5- 22	0.6
RT 101/L	25- 90	5.0
RT 102	25- 90	5.0
RT 108	30-140	2.0
RT 140/L	15- 45	3.1

RT units with solid charge

The method of operation of these units is based on the connection between the pressure and temperature of saturated vapour.

The sensor system contains a fairly large amount of liquid, of which only a small part is brought to vapour form. If the sensor in this type of unit is located warmest in relation to the capillary tube and bellows housing, the ambient temperature has no influence on regulation accuracy.

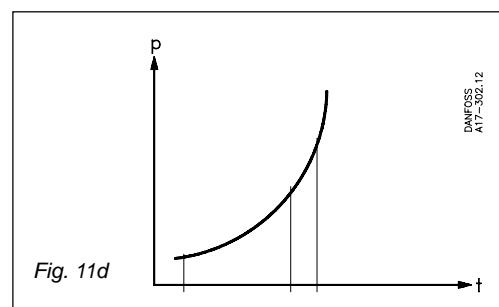

Thermostats, type RT

RT 115 for control of ventilation plant in livestock buildings

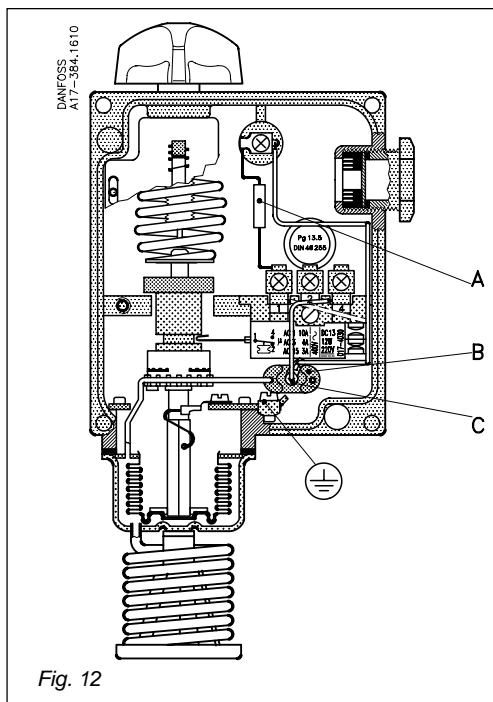

- A. Series resistor
- B. Bulb sensor
- C. Heating element

RT 115 has two sensors, each of which is connected to the space between bellows and bellows housing; see fig. 12. One sensor is a normal, external, rigid coiled capillary tube type, the other is a bulb sensor located in the thermostat housing.

The bulb sensor is heated by an element which is cut in when the thermostat stops the fans and is cut out when the thermostat starts the fans.

The for of operation is as follows:

If the room temperature is more than the value set on the thermostat, 20°C for example, the fans run continuously (100% operating time). If the room temperature falls to 20°C, the switch contacts changeover, the fan stops and the bulb sensor heating element cuts in.

When the bulb sensor is heated up, pressure in the sensor system increases and after a certain time the switch changes over and again thereby cutting in the fans and cutting out the element.

If the room temperature falls more than 2°C under the set temperature - in this example, lower than 18°C - the fans stop completely. The heating element is cut in as usual but can no longer heat the bulb sensor sufficiently to create the required pressure increase in the thermostatic element to cut in the fans again. Thus with a room temperature of less than 18°C the operating time is 0%.

An example is shown in fig. 13.

With temperature settings other than the one shown, the inclined line in the diagram is displaced parallel. The line break point on the right of the diagram always corresponds to the set value.

It is therefore possible to maintain a stable room temperature and at the same time obtain periodic ventilation where the duration of the ventilation periods depends on the difference between the actual room temperature and the set temperature. By ensuring that the thermostat is always set at least 2°C over the lowest permissible room temperature, the thermostat will never allow the room temperature to fall below the desired level.

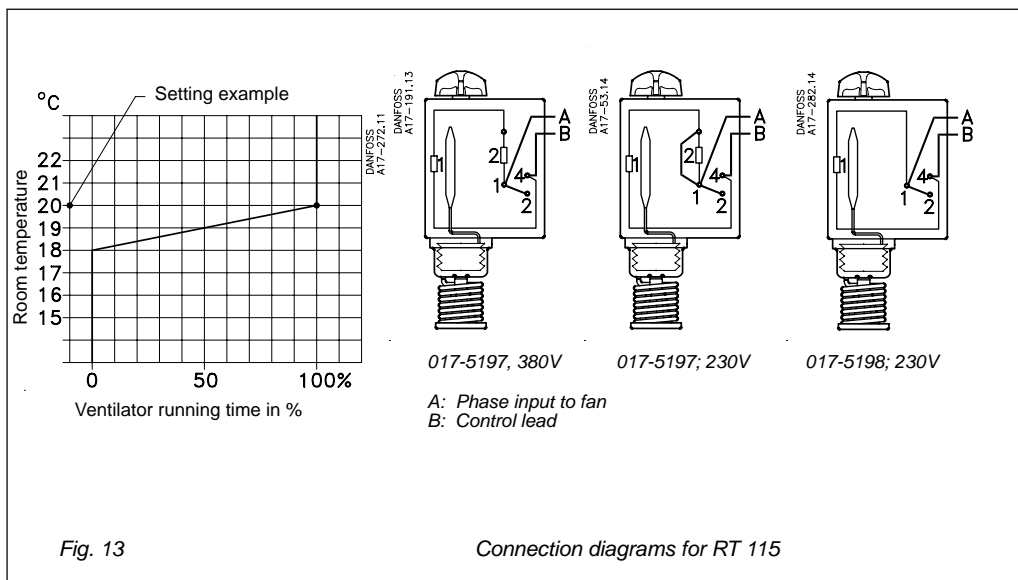

Fig. 13

Connection diagrams for RT 115

Thermostats with adjustable neutral zone, type RT-L

Application

RT-L thermostats are fitted with an adjustable neutral zone. This enables the units to be used for floating control. The terminology involved is explained below.

Floating control

A form of discontinuous control where the correcting element (e.g. valve, damper, or similar) moves towards one extreme position at a rate independent of the magnitude of the error when the error exceeds a definite positive and towards the opposite extreme position when the error exceeds a definite negative value.

Hunting

Periodic variations of the controlled variable from the fixed reference.

Neutral zone

The interval in the controlled variable in which the correcting element does not respond.

Mechanical differential

The interval between the values of the controlled variable in which the correcting element does not respond.

The contact system in neutral zone units cannot be exchanged, as the contact system adjustment is adjusted to the other parts of the unit.

Neutral zone setting

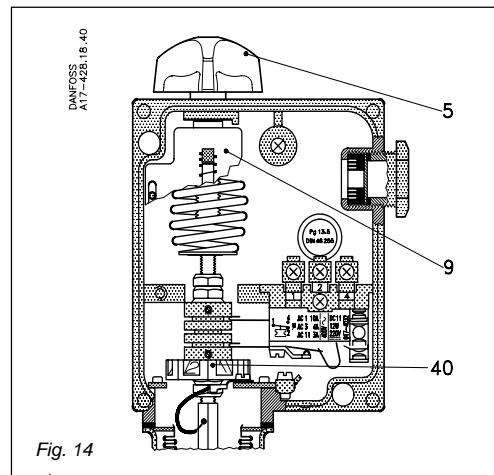

Fig. 14

- 5. Setting knob
- 9. Main scale
- 40. Neutral zone disc with scale

The range is set using the setting knob (5), fig. 14, while reading the main scale (9). The set value is the break temperature for contacts 1-4, fig. 15. The required neutral zone can be found in the diagram for the unit concerned, fig. 16. The position at which the neutral zone disc (40) must be set can be read from the low scale in the diagram.

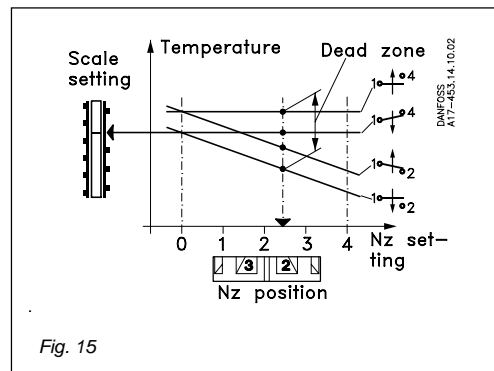

Fig. 15

Example: RT 16L

Setting temperature: +24°C

Required neutral zone: 1.9°C

Using the setting knob, set the thermostat on 24°C.

The dotted lines in the diagram for the RT 16L fig. 16 intersect each other on the curve for position 2.8 and the neutral zone setting disc (40) must be set to that position.

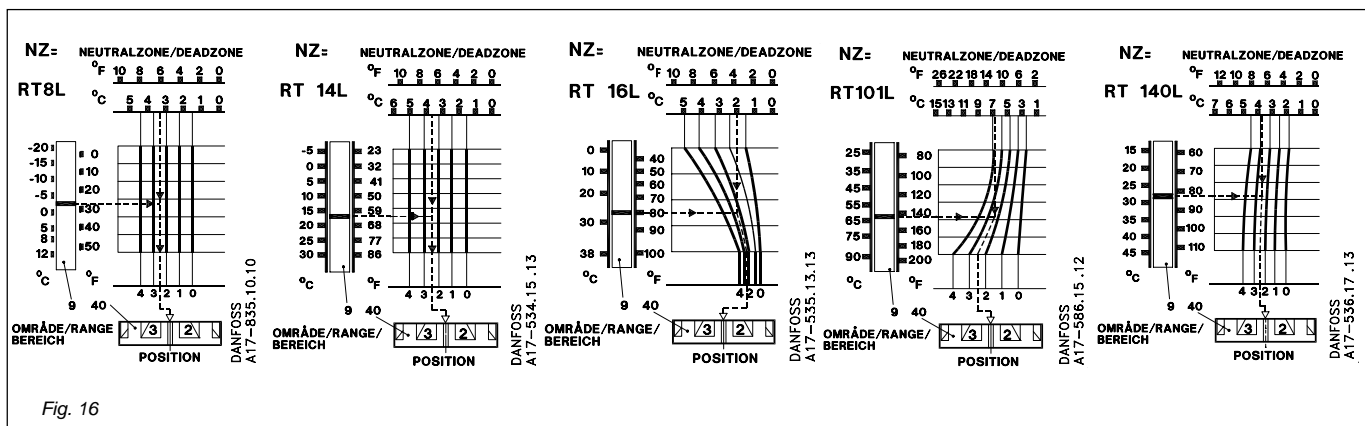

Fig. 16

Differential thermostats, type RT

Application

Control and monitoring of temperature differentials
 An RT differential thermostat is an electric single - pole changeover switch. The position of the switch contacts is controlled by the difference in temperature between the two sensors of the thermostat. The RT 270 is used in process plant, ventilation

plant and refrigeration and heating plant, where there is a need to maintain a certain temperature difference, from 0 to 20°C, between two media. One of the sensors is used as a reference, the other as an indirect controlled variable. (The direct controlled variable is the temperature differential).

Setting

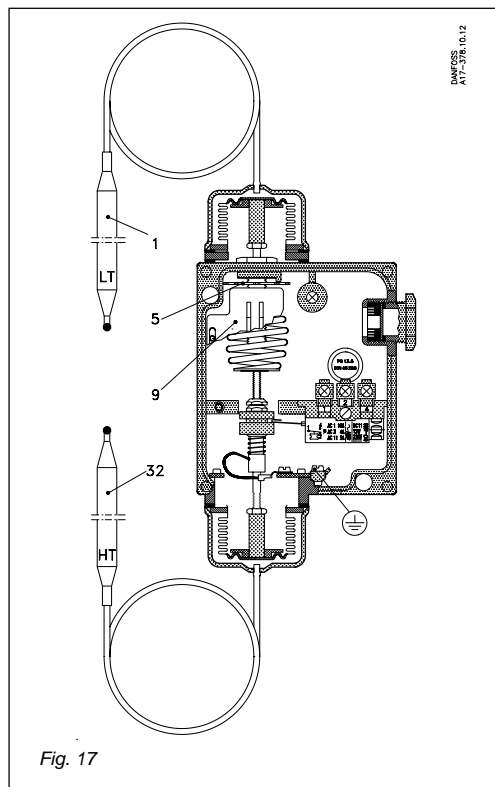

- 1. Sensor for the lowest temperature (LT)
- 5. Setting disc
- 9. Scale
- 32. Sensor for the highest temperature (HT)

The required temperature differential between the LT sensor (1) (lowest temperature) and the HT sensor (32) (highest temperature) is set using the setting disc (5) while reading the scale (9).

Fig. 17 is a cross-sectional drawing of the RT 270. The differential thermostat has two bellows elements: an LT element whose sensor must be placed in the medium with the lowest temperature, and an HT element whose sensor must be placed in the medium with the highest temperature.

The main spring has a rectilinear characteristic. Within the differential range it can be set for different temperature differentials by means of the setting disc.

When the differential between LT and HT sensor temperatures is reduced, the main spindle moves downwards.

The contact arm is moved downwards by the guide bush so that contact 1-4 break and contacts 1-2 make when the set temperature differential is reached.

The switch contacts change back when the temperature differential has increased to the set value plus the fixed contact differential of approx. 2°C.

Function

Differential thermostats are fitted with a changeover switch (SPDT)

When the differential temperature falls below the set value, contacts 1-4 break and contacts 1-2 make. When the differential temperature rises to the set range value plus the fixed contact differential, contacts 1-2 break and contacts 1-4 make.

- I. Contacts make when differential temperature falls below the range scale setting.
- II. Contacts make when differential temperature rises above the range scale plus the fixed contact differential.

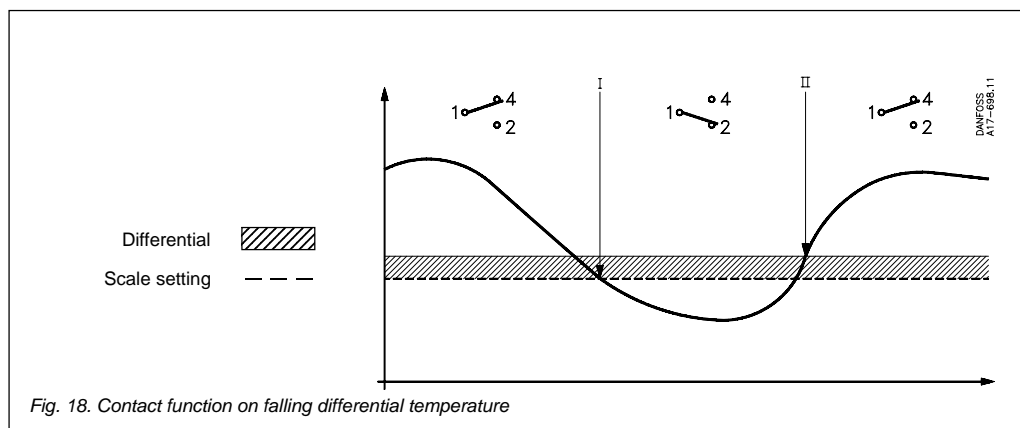

Example

The temperature rise across an air cooler must be held below 5°C. An alarm must be given when the differential temperature of the cooling water exceeds the 5°C

The choice is an RT 270 with a range of 0-15°C and a fixed contact differential of 2°C.
 Range setting: 5-2°C = 3°C
 When the differential temperature exceeds the range setting plus the fixed contact differential (3+2°C) an alarm will be given.

Pressure controls and thermostats, type RT

Spare parts and accessories

Version	Symbol	Description	Contact rating	Code no.
Standard		Single-pole changeover switch (SPDT) with terminal board proof against leakage current Fitted in all standard versions of type RT¹⁾. Snap action changeover contacts.		017-4030
With max. reset		For manual reset of unit after contact changeover on rising pressure For units with max. reset.	<i>Alternating current:</i> AC-1 (ohmic): 10 A, 400 V AC-3 (inductive): 4 A, 400 V AC-14/15 (coil/transformer): 3 A, 400 V Blocked rotor: 28 A, 400 V <i>Direct current:</i> DC 13/14: 12 W, 230 V	017-4042
With min. reset		For manual reset of units after contact changeover on falling pressure. For units with min. reset.		017-4041
Standard		Single-pole changeover switch (SPDT) with gold plated (oxide-free) contact surfaces. Increases cut-in reliability on alarm and monitoring systems, etc. Snap action changeover contacts. Terminal board proof against leakage current.	<i>Alternating current:</i> AC-1 (ohmic): 10 A, 400 V AC-3 (inductive): 2 A, 400 V AC-14/15: 1 A, 400 V Blocked rotor: 14 A, 400 V <i>Direct current:</i> DC-13/14: 12 W, 230 V	017-4240
Cuts in two circuits simultaneously		Single-pole changeover switch that cuts in two circuits simultaneously on rising pressure. Snap action changeover contacts. Terminal board proof against leakage current.	<i>Alternating current:</i> AC-1 (ohmic): 10 A, 400 V AC-3 (inductive): 3 A, 400 V AC-14/15: 2 A, 400 V Blocked rotor: 20 A, 400 V <i>Direct current:</i> DC-13/14: 12 W, 230 V	017-4034
Cuts out two circuits simultaneously		Single-pole changeover switch that cuts out two circuits simultaneously on rising pressure. Snap action changeover contacts. Terminal board proof against leakage current.	<i>Direct current:</i> DC-13/14: 12 W, 230 V * If current is led through contacts 2 and 4, i.e. terminals 2 and 4 connected but not 1, max. permissible load is increased to 90 W, 220 V ---.	017-4036
With non-snap action changeover contacts		Single-pole changeover with non-snap action changeover gold plated (oxide-free) contacts.	<i>Alternating or direct current:</i> 25 VA, 24 V	017-0181

The switch contacts are shown in the position they assume on falling pressure/temperature, i.e. after downward movement of the RT main spindle.

The setting pointer of the control shows the scale value at which contact changeover occurs on falling pressure/temperature. An exception is switch no. 017-4030 with max. reset where the setting pointer shows the scale value at which contact changeover occurs on rising pressure.





¹⁾ At load types with low currents/voltages contact failure may occur on the silver contacts because of oxidation. In systems where such a contact failure is of great importance (alarm etc.), gold plated contacts are recommended.

**Contact systems for neutral zone units are not available as spare parts.
Exchange not possible, as the contact system adjustment is adjusted to the other parts of the unit.**



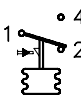







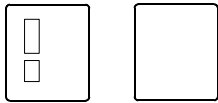





Pressure controls and thermostats, type RT

Spare parts and accessories

Switches

Version	Symbol	Description	Contact rating	Code no.
With min. reset		For manual reset of unit after contact changeover on falling pressure. For units with internal reset. Gold plated (oxide-free) contact surfaces		017-4047
With max. reset		For manual reset of unit after contact changeover on rising pressure. For units with internal reset. Gold plated (oxide-free) contact surfaces	<i>Alternating current:</i> AC-1 (ohmic): 10 A, 400 V AC-3 (inductive): 2 A, 400 V Full load current: 2 A, 400 V AC-14/15: 1 A, 400 V Blocked rotor: 14A, 400 V	017-4048
With min. or max. reset		With internal reset. For units with contact changeover on falling and rising pressure. Mounted in TÜV pressure controls Gold plated (oxide-free) contact surfaces	<i>Direct current</i> DC-13/14: 12W, 230 V	017-4049
With min. or max. reset		With internal reset For units with contact changeover on falling and rising pressure For units with internal reset. Mounted in TÜV pressure controls	<i>Contact load:</i> <i>Alternating current:</i> AC-1 (ohmic): 10 A, 400 V AC-3 (inductive): 4 A, 400 V AC-14/15 (coil/transformer): 3 A, 400 V Blocked rotor: 28A, 400 V <i>Direct current:</i> DC-13/14: 12W, 230 V (see also fig. 6, page 6)	017-4052

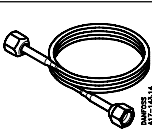
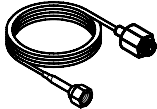
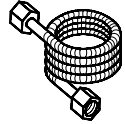
Accessories pressure controls

Part		Description	Qty.	Code no.					
Covers		Covers: Polyamide Colour: Pale grey RAL 7035 With window Without window	5 5	017-4361 017-4362					
Setting knob		Replacement setting knob: Pale grey Ral 7035	30	017-4363					
Seal cap		Seal cap to replace setting knob so that setting can only be altered with tools Black	20	017-4360					
Seal screw for cover and seal cap			20	017-4251					
Screwed cable entry		Screwed cable entry of nickel plated brass for replacement of standard nylon entry. To be used with cables protected with rigid material Thread = Pg 13.5 ext. x 3/8-18 UNF int.	10	614x6096					
Clamping band		For all RT pressure controls with damping coil or other longer connections L = 392 mm	10	017-4204					
Connector with nipple		Pipe thread ISO 228/1, G 3/8 connector, nipple and AL washer (10 mm ext. 6.5 mm int. diam) for welding or brazing on to steel or copper tubing	5	017-4368					
Reducer		Pipe thread ISO 228/1, G 3/8 x 7/16 - 20 UNF reducer, washer, brass, span of jaws 22	5	017-4205					
Connector		7/16 - 20 UNF connector for 1/4 copper tube, brass, span of jaws 16	10	011L1101					
Reducer		Pipe thread ISO 228/1, G 1/2 A x G 3/8, steel, span of jaws 22	1	017-4219					
Adaptor		Pipe thread ISO 228/1, G 3/8 x 1/8 - 27 NPT with copper washer, brass, span of jaws 22	1	060-3334					
Adaptor		Pipe thread ISO 228/1, G 3/8 A x 1/4 - 18 NPT with copper washer brass, span of jaws 22	1	060-3335					
Adaptor		Pipe thread ISO 228/1, G 3/8 x 1/4 - 18 NPT with copper washer brass, span of jaws 22	1	060-3336					
Adaptor		7/16 - 20UNF x R 3/8 (ISO 7/1) brass, span of jaws 19	1	060-3240					
Adaptor		Pipe thread ISO 228/1, G 3/8 A x R 3/8 (ISO 7/1) brass, span of jaws 17	1	060-3241					
Damping coil	 <table border="1" style="display: inline-table; vertical-align: middle;"> <tr> <td>0.50 m</td> </tr> <tr> <td>1.00 m</td> </tr> <tr> <td>1.50 m</td> </tr> <tr> <td>2.00 m</td> </tr> <tr> <td>6.00 m</td> </tr> </table>	0.50 m	1.00 m	1.50 m	2.00 m	6.00 m	Damping coil with 7/16 - 20 UNF connectors. Reducer code no. 017-4205 is necessary if the damping coil is to be used with RT units having a pipe thread ISO 228/1, G 3/8 connection. Damping coils with several lengths of capillary tubes are available. Please contact Danfoss	1	060-0190 060-0191 060-0192 060-0193 060-0054
0.50 m									
1.00 m									
1.50 m									
2.00 m									
6.00 m									
Damping coil		Pipe thread ISO 228/1, damping coil with G 3/8 connector and 1.5 m copper capillary tube. Standard washers are supplied.	1	060-1047					
Armoured damping coil		Pipe thread ISO 228/1, camping coil with G 3/8 connector and 1 m copper capillary tube. Standard washers are supplied.	1	060-3333					
Air bell for liquid level control RT 113		Air bell, 62 mm diam. ext. x 204 mm length. Pipe thread ISO 228/1, G 3/8 connector and nipple (10 mm o.d./ 6.5 mm i.d.) for welding or brazing on to steel or copper tubing. The air bells is of brass CuZn 37, W.no. 2.0321.	1	017-4013					

Accessories for thermostats

Part		Description	Qty.	Code no.	
Covers		Covers: Polyamide	5	017-4361	
		Colour: Pale grey RAL 7035	5	017-4362	
Setting knob		Replacement setting knob	30	017-4363	
Seal cap		Seal cap for replacement of setting knob so that setting can only be altered with tools	20	017-4360	
Seal screw for cover		For polyamide covers	20	017-4364	
Seal screw for seal cap			20	017-4251	
Capillary tube gland		For all RT thermostats with remote sensor. G $\frac{3}{4}$ A (pipe thread ISO 228/1), oil resistant rubber washer for max. 110°C/90 bar.	5	017-4220	
Capillary tube gland		For RT 106 thermostat with remote sensor. G $\frac{3}{4}$ A (pipe thread ISO 228/1), oil resistant rubber washer for max. 110°C/90 bar.	1	003N0155	
Sensor clip		For all RT units with remote sensor	L = 76 mm	10	017-4203
Screwed cable entry		Screwed cable entry of nickel plated brass for replacement of screwed standard nylon entry. To be used with rigid conduit. Thread = Pg 13.5 ext. x $\frac{5}{8}$ -18 UNF int.	10	614x6096	
Clamping band		For all RT pressure controls with damping coil or other length of connection L=392 mm	10	017-4204	
Heat conductive compound		For RT thermostats with the sensor insert in a pocket. Tube with 3.5 cm ³ compound to be filled in the sensor pocket to improve heat transfer between pocket and sensor. The tin contains 750 gr. Application range for compound: -20 til + 150°C, momentarily up to 220°C.	1	Tube 041E0110	
			1	Tin 041E0111	
Sensor holder		For RT 14, 101 and 270 Sensor holder for wall mounting incl. four capillary tube clips	20 set	017-4201	

Sensor pocket for RT thermostats with cylindrical remote sensor

Used for the following types		Insertion length L mm	d mm	Material	Connection pipe thread ISO 228/1	Code no.
All except RT 12, 23, 106, 108, 124, 270		112	11	Brass	G $\frac{1}{2}$ A	017-4370
All except RT 12, 23, 106, 108, 124, 271		112	11	Stainless 18/8	G $\frac{1}{2}$ A	017-4369
RT 106, RT 124 ²⁾		110	15	Brass	G $\frac{1}{2}$ A	060L3271¹⁾
RT 106, RT 124 ²⁾		110	15	Stainless 18/8	G $\frac{1}{2}$ A	060L3268¹⁾
RT 106, RT 124 ²⁾		160	15	Brass	G $\frac{1}{2}$ A	060L3263¹⁾
RT 106, RT 124 ²⁾		160	15	Stainless 18/8	G $\frac{1}{2}$ A	060L3269¹⁾
RT 271		182	11	Brass	G $\frac{1}{2}$ A	017-4367
RT 108		465	11	Brass	G $\frac{1}{2}$ A	017-4216

¹⁾ Supplied without washer set

²⁾ Unit supplied with washer set code no. 060L3274

See possibly page 21

Units for monitoring of pressure and temperature controls, type, type RT

Danfoss can accept no responsibility for possible errors in catalogues, brochures and other printed material. Danfoss reserves the right to alter its products without notice. This also applies to products already on order provided that such alterations can be made without subsequential changes being necessary in specifications already agreed. All trademarks in this material are property of the respective companies. Danfoss and the Danfoss logotype are trademarks of Danfoss A/S. All rights reserved.

**DK-6430 Nordborg
Denmark**